

THE RADIO EXPERIMENTER'S MAGAZINE

SHORT WAVE ★ CRAFT

Edited by
HUGO GERNSBACK

April 34

*Best Short Wave
Station List
of the World*

**When to hear
the
Foreign Stations**

*ALL IN THIS
ISSUE*

THE **Tetradyne**

4 SETS IN 1

See Page 716

3870

25¢
IN CANADA
30¢

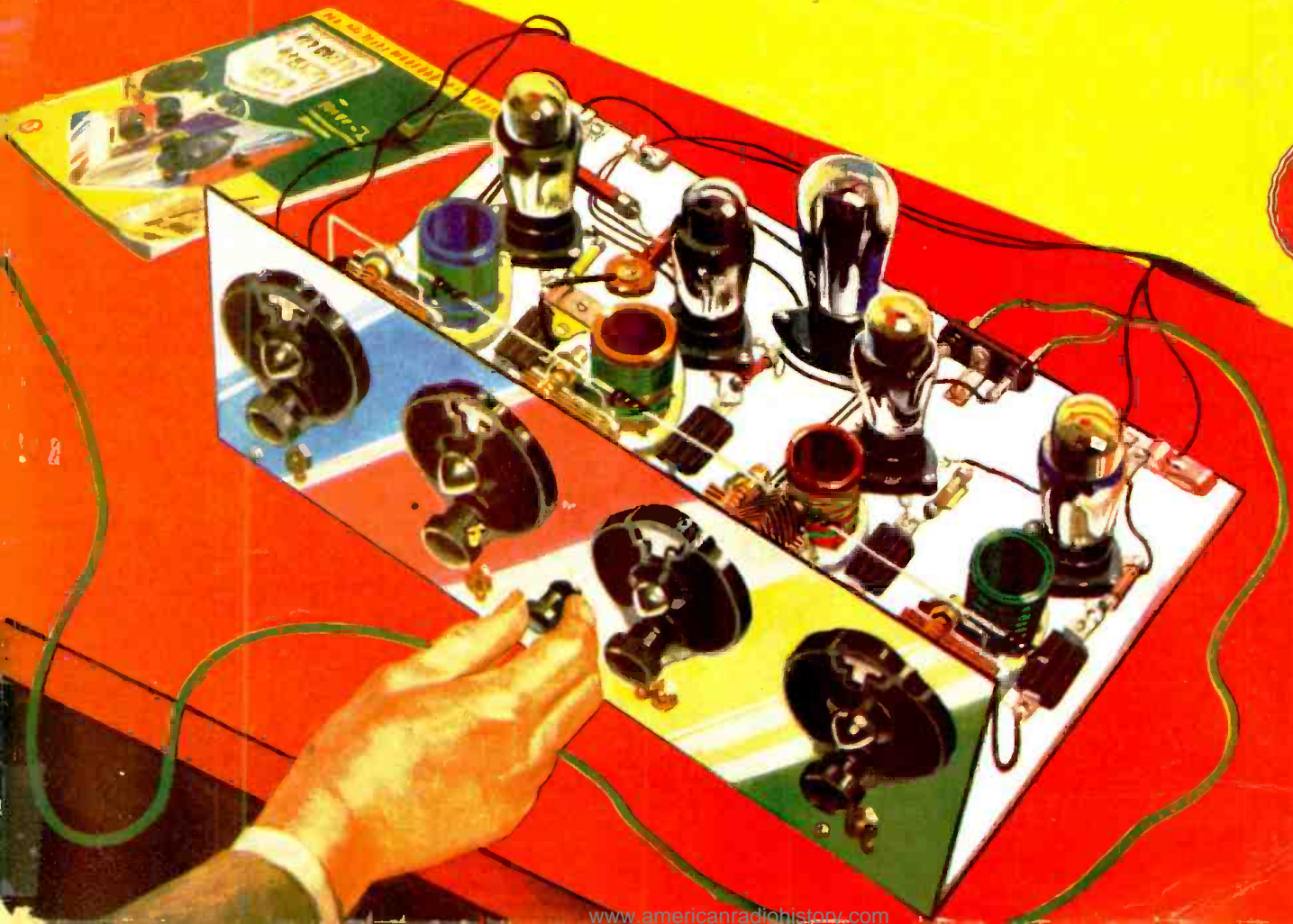

RUBINOFF gives a Tip— *that brings new joy to radio listeners*



NEW RADIO TUBES
Improved 5 ways by



Get This New Radio Thrill

Have your dealer test your tubes today. Insist on the only tubes guaranteed by RCA Radiotron Co., Inc., to have these 5 vital improvements:

- 1 Quicker start
- 2 Quieter operation
- 3 Uniform volume
- 4 Uniform performance
- 5 Every tube is matched



**Lunningham
Radiotron**



The 4 ESSENTIAL SHORT WAVE BOOKS

'ROUND THE WORLD FANS USE THESE GREAT SHORT WAVE BOOKS

These great books contain everything on short waves that is really worth knowing—they are books which have been most enthusiastically welcomed by short-wave fans. The cost of the books is extremely low in comparison with the valuable material which they contain.

There is not a short-wave fan, experimenter or interested radio-minded reader who will not want these books. Right up-to-the-minute with new material on outstanding developments in the short wave field. The books are authoritative, completely illustrated and not too highly technical.

Ten Most Popular Short Wave Receivers. How to Make and Work Them

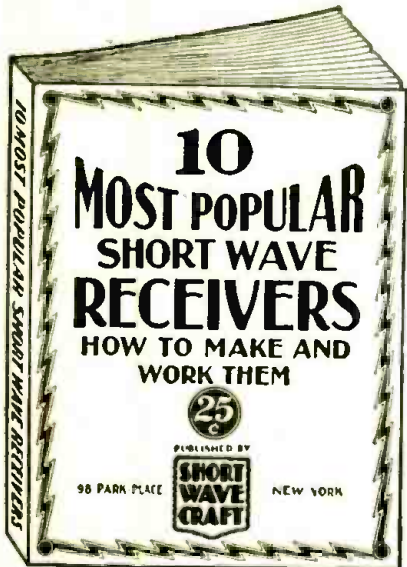

This new volume is a revelation to those who wish to build their own short wave receivers. The editors of **SHORT WAVE CRAFT** have selected ten outstanding short wave receivers and these are described in the new volume. Each receiver is fully illustrated with a complete layout, pictorial representation, photographs of the set complete, hookup and all worthwhile specifications. Everything from the simplest one tube set to a 5-tube T. R. F. receiver is presented. Complete lists of parts are given to make each set complete. You are shown how to operate the receiver to its maximum efficiency.

CONTENTS

- The Doerle 2-Tube Receiver That Reaches the 12,500 Mile Mark, by Walter C. Doerle.
- 2-R.F. Pentode SW Receiver having two stages of Tuned Radio Frequency, by Clifford E. Denton and H. W. Secor.
- My de Luxe S-W Receiver, by Edward G. Ingram.
- The Binneweg 2-Tube 12,000 Mile DX Receiver, by A. Binneweg, Jr.
- Build a Short Wave Receiver in your Brief-Case, by Hugo Gernsback and Clifford E. Denton.
- The Denton 2-Tube All-Wave Receiver, by Clifford E. Denton.
- The Denton "Stand-By," by Clifford E. Denton.
- "Stand-By" Electrified.
- The Short-Wave MEGADYNE, by Hugo Gernsback.
- A COAT-POCKET Short Wave Receiver, by Hugo Gernsback and Clifford E. Denton.
- Boy, Do They Roll In on the One Tube! by C. E. Denton.
- The S-W PENTODE-4, by H. G. Clair, M. E.
- Louis Martin's Idea of A GOOD S-W RECEIVER, by Louis Martin.

40 PAGES
OVER 75 ILLUSTRATIONS
IMPORTANT

THERE IS NO DUPLICATION BETWEEN THIS BOOK AND OUR OTHER VOLUME—"HOW TO BUILD AND OPERATE SHORT WAVE RECEIVERS." ALL THE MATERIAL PUBLISHED IN THE NEW BOOK HAS NEVER APPEARED IN ANY BOOK BEFORE.

25c

How to Build and Operate Short Wave Receivers

is the best and most up-to-date book on the subject. It is edited and prepared by the editors of **SHORT WAVE CRAFT**, and contains a wealth of material on the building and operation, not only of typical short-wave receivers, but short-wave converters as well. Dozens of short-wave sets are found in this book, which contains hundreds of illustrations; actual photographs of sets built, hookups and diagrams galore.

The book comes with a heavy colored cover, and is printed throughout on first-class paper. No expense has been spared to make this the outstanding volume of its kind. The book measures 7½x10 inches.

This book is sold only at such a ridiculously low price because it is our aim to put this valuable work into the hands of every short-wave enthusiast.

We know that if you are at all interested in short waves you will not wish to do without this book. It is a most important and timely radio publication.

Over 150 Illustrations
72 Pages 7x10 Inches

50c

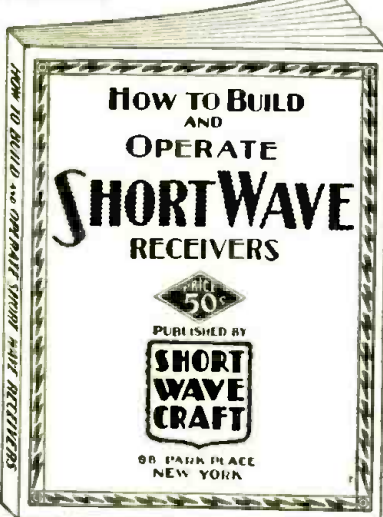

How to Become an Amateur Radio Operator

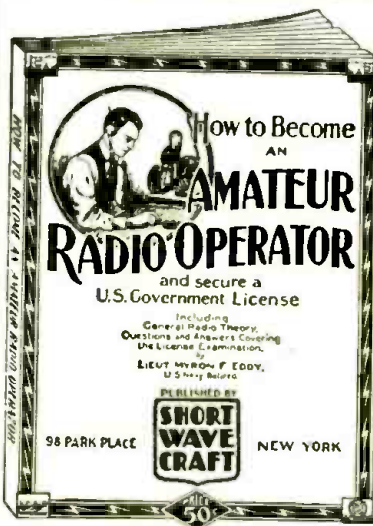

We chose Lieut. Myron F. Eddy to write this book because his long years of experience in the amateur field have made him pre-eminent in this line. For many years he was instructor of this line. For many years he was instructor of radio telegraphy at the R.C.A. Institute. He is a member of the I.R.E. (Institute of Radio Engineers), also the Veterans Wireless Operators' Association.

If you intend to become a licensed code operator, if you wish to take up phone work eventually, if you wish to prepare yourself for this important subject—this is the book you must get.

Partial List of Contents
Ways of learning the code. A system of sending and receiving with necessary drill words is supplied so that you may work with approved methods. Concise, authoritative definitions of radio terms, units and laws, brief descriptions of commonly used pieces of radio equipment. This chapter gives the working terminology of the radio operator. Graphic symbols are used to indicate the various parts of radio circuits. General radio theory, particularly as it applies to the beginner. The electron theory is briefly given, then waves—their creation, propagation and reception. Fundamental laws of electronic circuits, particularly those used in radio are explained next and typical basic circuits are analyzed. Descriptions of modern receivers that are being used with success by amateurs. You are told how to build and operate these sets. Amateur transmitters. Diagrams with specifications are furnished so construction is made easy. Power equipment that may be used with transmitters and receivers, rectifiers, filters, batteries, etc. Regulations that apply to amateur operators. Appendix which contains the International "Q" signals, conversion tables for reference purposes, etc.

Over 150 Illustrations
72 Pages 7x10 Inches

50c

All the books shown on this page are published exclusively by

SHORT WAVE CRAFT

96-98 Park Place, New York, N. Y.

CLIP-MAIL

SHORT WAVE CRAFT
96-98 Park Place, New York, N. Y.

Gentlemen: I enclose herewith my remittance for the amount of \$..... for which you are to send me, postpaid, the books checked below.

- () Ten Most Popular Short Wave Receivers. How to Make and Work Them. 25c each
- () The Short Wave beginner's Book..... 25c each
- () How to Build and Operate Short Wave Receivers..... 50c each
- () How to Become an Amateur Radio Operator..... 50c each

Name.....
Address.....
City..... State.....

(Send remittance in form of check or money order. If letter contains cash or unused U. S. Postage Stamps, register it.)

SW-4-34

These Books are Authentic For All Short Wave Work and LOW in Price

COUPON TODAY!

IN THIS ISSUE: PROMINENT SHORT-WAVE AUTHORS

Kostler . Andrews . Potter . Shuart . Victor . Palmer



HUGO GERNSBACK
Editor

H. WINFIELD SECOR
Managing Editor

Contents for April, 1934

Editorial—Short Waves in 1934, by Hugo Gernsback.. 711
 W2XE—The Short-Wave Voice of the Columbia Broadcasting System 712
 Radio Cop Has "A-1" Station..... 713
 ¼ Meter Portable Transmitter and Receiver, by Charles Kost'er, short-wave consultant, assisted by Donald Converse 714
 Now the TETRADYNE! By Hugo Gernsback..... 716
 A "Good" 14-Tube S.W. Receiver, by Frank D. Andrews 718
 The New "Stand-By" Short-Wave Receiver, by Clifford E. Denton 720
 STATIC ALARM—Short Wave Fiction, by Arnold Douglas Finley 722
 Unitrol Receiver Simplifies "Band-Spread" Tuning, by George W. Shuart, W2AMN..... 723
 World-Wide Short-Wave Review, edited by C. W. Palmer 724
 Short-Waves and Long Raves—Our Readers' Forum.. 726
 How Short-Wave "Ham" Relayed Plane's Rescue Message 727
 5-Meter Transmitter-Receiver, by Marcus L. Potter, W9FQU 728
 CRYSTAL-CONTROL For the Lean Purse, by Bernhard Stahl 730
 New ALL-WAVE Set Features Quadri-Color Tuning Scale 732
 Short Wave Scouts—Second "TROPHY WINNER".... 733
 What's New In Short-Wave Apparatus..... 734
 A New 2-Tube Short-Wave Converter..... 735
 A.C. "Monitor" for Hams and Short-Wave Listeners, by Leonard J. Victor..... 735
 The 1-Tube Short-Wave Scout..... 736
 Why Battery-Operated S.W. Sets are Better, by C. W. Palmer 736
 SHORT WAVE LEAGUE..... 737
 The "RT" 5-Meter Transmitter, by George W. Shuart, W2AMN 738
 SHORT-WAVE STATIONS OF THE WORLD—revised to date, Edited by M. Harvey Gernsback..... 739
 When To Listen In, by M. Harvey Gernsback..... 741
 Short-Wave QUESTION BOX..... 742



Certified Circuits

• **SHORT WAVE CRAFT** goes to a large expense in verifying new circuits published in this magazine. Whenever you see the seal shown here in connection with any of the sets published in this and future issues of **SHORT WAVE CRAFT**, this will be your guarantee that this set has been tested in our laboratories, as well as privately, in different parts of the country to make sure that the circuit and selected parts are right. Only "Constructional-Experimental" circuits are certified by us.

When you see our certificate seal on any set described you need not hesitate in spending money for parts, because you are assured in advance that the set and circuit are bona fide and that this magazine stands behind it.

SHORT WAVE CRAFT is the only magazine that thus certifies circuits and sets.

OUR COVER

• **THE** cover illustration this month shows the very newest idea in short-wave receivers—the **TETRADYNE!** This receiver embodies four distinct detector tuning circuits, which are always ready at the turn of a switch to provide tuning in any desired band, obviating the use of "plug-in" coils. It is described by Hugo Gernsback, its inventor, on page 716

COPYRIGHT, 1934, BY H. GERNSBACK

Published by **POPULAR BOOK CORPORATION**

HUGO GERNSBACK, President - - - - H. W. SECOR, Vice-President
 EMIL GROSSMAN - - - - - Director of Advertising
 Chicago Adv. Office - - - - L. F. McCLURE, 919 No. Michigan Ave.
 Publication Office - - - - 401 N. Wesley Avenue, Mount Morris, Ill.
 Editorial and General Offices - - - 96-98 Park Place, New York, N. Y.
 London Agent: HACHETTE & CIE., 16-17 King William St., Charing Cross, W.C.2
 Paris Agent: HACHETTE & CIE., 111 Rue Reaumur
 Australian Agents: MCGILL'S AGENCY, 179 Elizabeth St., Melbourne

FEATURES IN MAY ISSUE

- A New 5-Tube T.R.F. Short-Wave Receiver, by M. Harvey Gernsback.
- The 1-Tube Electrodyne—An Improved 1-Tube S.W. Receiver, by Leonard Victor.
- All About "Band Spread"—Various Ways of Making Short-Wave Tuning Easier, by George W. Shuart, W2AMN.
- 5-Meter Field Strength Measurements—including data on 5-Meter Transmitter and Receiver Construction, by C. I. Schultz.
- An Improved "Ham" Transmitter, by Curtis E. Malsberger.
- Details of Heinie Johnson's Receiver—the one with which he won the **SHORT WAVE SCOUT "Trophy Cup."**

SHORT-WAVE CRAFT—Monthly. Entered as second class matter May 7, 1930, at the post office at Mount Morris, Illinois, under the act of March 3, 1879. Trademarks and copyrights by permission of H. Gernsback, 98 Park Place, N. Y. C. Text and illustrations of this magazine are copyrighted and must not be reproduced without permission. **SHORT WAVE CRAFT** is published on the 5th of every month. Twelve numbers per year. Subscription price is \$2.50 a year in the United States and possessions, Canada and foreign countries, \$3.00 a year. Single copies 25c. Address all contributions for publication to Editor, **SHORT WAVE CRAFT**, 96-98 Park Place, New York, N. Y. Publishers are not responsible for lost manuscripts. Contributions cannot be returned unless authors remit full postage. **SHORT WAVE CRAFT** is for sale at all principal newsstands in the United States and Canada. European agents: Brentano's, London and Paris. Printed in U. S. A. Make all subscription checks payable to Popular Book Corporation.

WORLD-WIDE SHORT-WAVE STATIONS

Nearly 9,000 Short-Wave Radio
Stations Listed in This Book

For Sale On All Principal
Newsstands
Look for the Yellow Cover

25c

A Copy



WE ARE happy to present to our friends, the second issue of the OFFICIAL SHORT WAVE LOG AND CALL MAGAZINE, just off press. To the thousands of readers who bought the first issue, we express our thanks, with the hope that they liked our Presentation. And those of you who bought the first issue certainly will wish to get the second one, as it is far more complete than the first. It has been entirely revised, and brought up to date, up to the time we went to press. There are nearly 9,000 listings of radio phone short-wave stations in this magazine, and, from the very nature of it, you appreciate how many changes occur from month to month.

ONLY ONE OF ITS KIND

THE OFFICIAL SHORT WAVE LOG AND CALL MAGAZINE is the only publication in print that publishes ALL the short-wave phone stations of the world. Thousands of stations that the average listener hears are listed here, and you need no longer be puzzled as to whence the call emanates. As only a limited quantity was printed for the second issue, it is possible that your newsdealer sold out his supply. Should you not be able to secure a copy at your newsstand, use the handy coupon. This is one of the finest books that the publishers of SHORT WAVE CRAFT have ever turned out. You will be proud to possess it. The size of this book is 9x12 inches, same size as SHORT WAVE CRAFT magazine. It is printed on a good grade of paper and has a heavy durable cover.

SHORT WAVE CRAFT 96-98 PARK PLACE
NEW YORK, N. Y.

MAIL THIS COUPON TODAY!

SHORT WAVE CRAFT
96-98 Park Place, New York, N. Y.
Gentlemen: I enclose herewith 25c for which send me prepaid, immediately a copy of your new OFFICIAL SHORT WAVE LOG AND CALL MAGAZINE. (Send money order, check, cash or new U. S. Stamps. Register letter if it contains stamps or currency.)

Name
Address
City State

SW-4-34

Partial Contents

1. THE OFFICIAL SHORT WAVE LOG AND CALL MAGAZINE contains the largest listing of short-wave stations in the world. BECAUSE OF SPACE LIMITATIONS, NO REGULAR MAGAZINE CAN PUBLISH ALL THE WORLD STATIONS. There are so many short-wave stations which normally cannot be included in any monthly magazine; but frequently you hear these calls, and you must know where they come from. THE OFFICIAL SHORT WAVE LOG AND CALL MAGAZINE gives you this information, besides a lot of other data which you, as a short-wave enthusiast, must have.

2. Log List. The log section gives you dial settings, time, date, call letters, location, and other information. Thus, when you hear a station, you make a permanent record, which is invaluable.

3. Another large section has squared-paper pages on which you can fill in your own frequency (wave-length) curve for your particular receiver. This helps you to find stations which otherwise could never be logged by you. These tuning charts are listed in two sections; one reading 0 to 100 degrees and the other from 0 to 150 degree tuning dial.

4. World Airline Distance Chart, showing the approximate distance between principal cities of the world. Invaluable in quickly verifying distances from any country in the world.

5. A new "Meter to kilocycle" conversion chart. Quite often short-wave broadcast phone stations announce their frequency on the latter scale when signing off, and many listeners do not know the relation between them. A chart anyone can read.

6. A list of international abbreviations used in radio transmission.

7. A chart of complete Morse and Continental International Code Signals, as used in all radio work.

8. World Time Chart. This tells you instantly what the time is, anywhere in the world. Necessary for every short-wave listener.

9. Improving your Short Wave Reception. An invaluable chapter by the well-known authority on short waves, Clifford E. Denton.

10. Identification chart of stations by their call letters.

11. Map giving the standard time zones of the entire world, for quick reference.

12. New and complete list of phone stations on the ocean liners.

13. "Q" readability systems. "T" Tone system. "R" audibility system. Invaluable to amateurs.

14. New Straight-Line World Distance Chart.

15. International prefixes by which you can recognize each foreign country when you hear a call.

Mr. Hugo Gernsback,
96-98 Park Place, New York City.
Fairview, Oklahoma.
I have just finished reading your Newest Brain Child the Official Short Wave Log and Call Book, and find it good. Although I am no critic, but I have followed through your radio publications your efforts for better radio. Your attempts to bring the user in to the light that radio is the cleanest sport that man has found for a hobby and taught the manufacturers of radio sets that the buying public wants to also know the circuits involved, you have carried a campaign for the release of data for the service man. In all Mr. Gernsback, I have grown to manhood reading your radio publications and I hope that my sons find them as interesting as I do as I have two small sized "flams".
So Mr. Gernsback why not say to you, you have found your work and it is well done.
73 (a) E. B. ALLEN, 483 Fairview, Oklahoma.

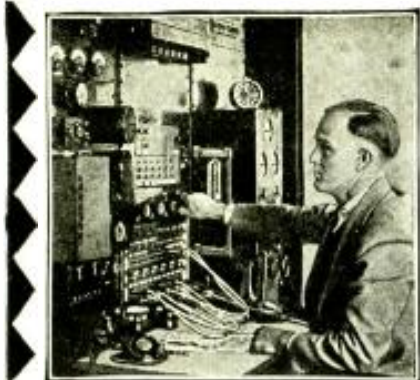

Broadcasting Stations employ managers, engineers, operators, installation and maintenance men for jobs paying up to \$5,000 a year.



Police Departments are finding Radio a great aid in their work. Many good jobs have been made in this new field.



Spare time set servicing pays many N.R.I. men \$5, \$10, \$15 a week extra. Full time men make as much as \$40, \$60, \$75 a week.

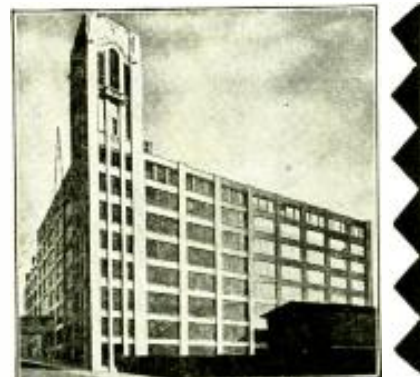

Radio Factories—Employ testers, inspectors, foremen, engineers, servicemen, for jobs paying up to \$7,500 a year.



Television—the coming field of many great opportunities—is covered by my Course.

I WILL TRAIN YOU AT HOME

Many Make \$40, \$60, \$75 a Week in Radio -- *the Field With a Future*

My book, "Rich Rewards in Radio," gives you full information on the opportunities in Radio and explains how I can train you quickly to become a Radio Expert through my practical Home-Study training. It is free. Clip and mail the coupon NOW. Radio's amazing growth has made hundreds of fine jobs which pay \$40, \$60 and \$75 a week. Many of these jobs may quickly lead to salaries as high as \$100, \$125 and \$150 a week.

Radio — the Field With a Future

Ever so often a new business is started in this country. You have seen how the men and young men who got into the automobile, motion picture and other industries when they were started had the first chance at the big jobs—the \$5,000, \$10,000 and \$15,000 a year jobs. Radio offers the same chance that made men rich in those businesses. It has already made many men independent and will make many more wealthy in the future. You will be kicking yourself if you pass up this once-in-a-lifetime opportunity for financial independence.

Many Radio Experts Make \$40, \$60, \$75 a Week

In the short space of a few years 300,000 Radio jobs have been created, and thousands more will be made by its future development. Men with the right training—the kind of training I will give you in the N.R.I. Course—have stepped into Radio at 2 and 3 times their former salaries. Experienced servicemen as well as beginners praise N.R.I. training for what it has done for them.

Many Make \$5, \$10, \$15 a Week Extra In Spare Time Almost At Once

My Course is world-famous as the one "that pays for itself." The day you enroll I send you instructions, which you should master quickly, for doing 28 Radio jobs common in most every neighborhood. Throughout your Course I will show you how to do other repair and service jobs on the side for extra money. I will not only show you how to do the jobs but how to get them. I'll give you the plans and ideas that have made \$200 to \$1,000 a year for hundreds of fellows. G. W. Page, 110 Raleigh Apts., Nashville, Tenn., writes: "I made \$935 in my spare time while taking your Course." My book, "Rich Rewards in Radio," gives many letters from students who earned four, five and six times their tuition fees before they graduated.

Get Ready Now for Jobs Like These

Broadcasting stations use engineers, operators, station managers and pay up to \$5,000 a year. Radio manufacturers employ testers, inspectors, foremen, engineers, servicemen, buyers and managers for jobs paying up to \$7,500 a year. Radio dealers and jobbers (there are over 35,000) employ servicemen, salesmen, buyers, managers and pay up to \$100 a week. There are hundreds of opportunities for you to have a spare time, or full time Radio business of your own—to be your own boss. I'll show you how to start your own business with practically no capital—how to do it on money made in spare time while learning. My book tells you of other opportunities. Be sure to get it at once. Just clip and mail the coupon.

I HAVE STARTED MANY IN RADIO AT 2 AND 3 TIMES



Now Owns Own Business



\$120 a Month in Spare Time



Made \$17 in One Night

"If I had not taken your Course I would be digging ditches instead of running my own business. One week I made \$75 on repairing alone, and this doesn't count sales. If a fellow wants to get into Radio, N.R.I. is the starting point."—R. S. Lewis, Modern Radio Service, Pittsfield, Ill.

"I'm servicing from 3 to 5 sets daily in spare time, and average \$120 a month from my Radio work. I still hold my regular day job. I owe my success to N.R.I."—A. E. Farmer, 1012 Denison St., Muskogee, Okla.

"Who says there's a depression? I have made more money in Radio than ever before. I am busy day and night. Last night I made \$17. Last week, \$45. I had a tough struggle at first but you fellows helped me back in the race and kept me going." — William J. Maki, Creighton Mine, Ont., Canada.

TO BE A RADIO EXPERT

Act Now --- Mail Coupon Below for Free Book of Facts and Proof

You Can Learn at Home in Your Spare Time to be a Radio Expert

Hold your job. There is no need for you to leave home. I will train you quickly and inexpensively during your spare time. You don't have to be a high school or college graduate. My Course is written in a clear, interesting style that most anyone can grasp. I give you practical experience under my 50-50 method of training—one-half from lesson books and one-half from practical experiments with equipment given without extra charge. This unique and unequalled method has been called one of the greatest developments in correspondence Radio training. N.R.I. pioneered and developed it. It makes learning at home easy, fascinating, practical.

Television, Short Wave, Loud Speaker Systems Included

There's opportunity for you in Radio. Its future is certain. Television, short wave, loud speaker systems, police Radio, automobile Radio, aircraft Radio—in every branch, developments and improvements are taking place. Here is a real future for thousands and thousands of men who really know Radio—men with N. R. I. training. Get the training that opens the road to good pay and success.

Your Money Back if You are Not Satisfied

I will give you an agreement in writing, legal and binding upon this Institute, to refund every penny of your money upon completing my Course if you are not satisfied with my Lessons and Instruction Service. The resources of the National Radio Institute, Pioneer and World's Largest Home-Study Radio School, stand behind this agreement.

Find Out What Radio Offers. Get My Book

One copy of my valuable 64-page book, "Rich Rewards in Radio," is free to any resident of the U. S. and Canada over 15 years old. It has started hundreds of men and young men on the road to better jobs and a bright future. It has shown hundreds of men who were in blind-alley jobs, how to get into easier, more fascinating, better-paying work. It tells you where the good Radio jobs are, what they pay, how you can quickly and easily fit yourself to be a Radio Expert. The Coupon will bring you a copy free. Send it at once. Your request does not obligate you in any way. Mail coupon in envelope or paste on post card. ACT NOW.

J. E. SMITH, President
Dept. 4DB3, National Radio Institute
Washington, D. C.

FORMER PAY



**Good Position,
Good Pay**

"I am Chief Operator at Radio Station WSMK. This is a good position with good pay. I have advanced in Radio right along. I recommend N. R. I. to anyone who wants to be successful in Radio."—JOHN HAJDUK, JR., 3 Broxey Apts., Southern Hills, Dayton, Ohio.



Sample Lesson FREE



Mail the coupon today, and in addition to my big free book, "Rich Rewards in Radio," I'll send you my text, "Short Wave Receivers and Transmitters." Only my students could get this book in the past. Here's up-to-date information on the latest phase of Radio. 30 pages packed with fascinating details of this important new development. Learn about the new Detector Circuit, Short Wave Coils and Condensers, Audio Amplifier, Short Wave Superheterodyne, etc. Also complete construction details for practical circuits. Mail the coupon at once. Act now—and receive the late technical information on this fascinating subject.

SPECIAL Radio Equipment for Broad Practical Experience Given Without Extra Charge



My Course is not all theory. I'll show you how to use my special Radio equipment for conducting experiments and building circuits which illustrate important principles used in such well-known sets as Westinghouse, General Electric, Philco, R. C. A., Victor, Majestic and others. You work out with your own hands many of the things you read in our lesson books. This 50-50 method of training makes learning at home easy, interesting, fascinating, intensely practical.

Clip and mail NOW for FREE INFORMATION

J. E. SMITH, President,
National Radio Institute, Dept. 4DB3,
Washington, D. C.

Dear Mr. Smith: I want to take advantage of your Special Offer. Send me your two books, "Short Wave Receivers and Transmitters" and "Rich Rewards in Radio." I understand this does not obligate me.

Name Age

Address

City State

32FR

The 6 Best Radio Books

We herewith present the six most important books in radio. These volumes have been selected after an exhaustive study of the foremost radio books published today. They represent the finest in radio books, and offer a variety of information on the subject.
WE PUBLISH NO CATALOG, and ask you to please order from this page. Prompt shipments of all books will be made

to you directly from the publishers. We act only as a clearing house for a number of radio publishers, and **OUR PRICES ARE AS LOW OR LOWER THAN WILL BE FOUND ANYWHERE.** Remit by money order or certified check. Register all letters which contain cash.

THESE BOOKS ARE ALSO OUR 6 BEST SELLERS.

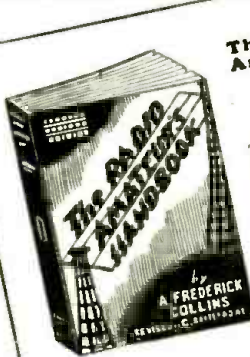

The Radio Amateur's Handbook
 (New Revised Edition).
 By A. FREDERICK COLLINS
 Cloth covers, size 5 3/4 x 7 3/4". 394 pages,
 116 illustrations

This standard book on radio appeared among the first, and has been continually reprinted and revised, not only to meet the demand, but also to present constantly a work that is always up-to-date.
 The book is almost entirely new in contents. Here are the important chapters: How to Begin Radio; The Transmitter and Receiver; Simple Telegraph and Electrical Tuning; Regenerative Sets; Work; Mechanical and Electrical Receivers; Electricity Sets; Work; Detectors; Short-Wave Receivers; Receiving Vacuum Tube Sets; Short-Wave Receiver; A Simple Amplifier; The Hamphotograph Amplifier; Five Receiving Sets; The Hamphotograph; Vacuum Tubes; A 245 Pushpull Radio Tube; Operation of Waxenets; Radio Transmitters; Construction and Use of Waxenets; Radio and Talking Motion Pictures; The Photoelectric Cell and its Uses; Ultra-Short Waves; Appendix.
Your Price \$1.97

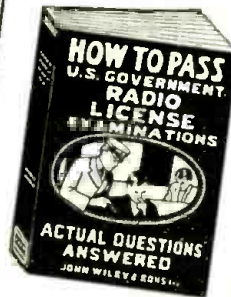

How to Pass U. S. Government Radio License Examinations
 By R. L. DUNCAN and C. E. DREW
 Flexible covers, size 9 1/2 x 7". 170 pages,
 92 illustrations

This is the most important book on this subject ever written. It gives every conceivable article which will help you to pass a radio license examination successfully.
 Here are the contents: Standard Regulations Governing the Issuance of Radio Operator's Licenses; Commercial and Broadcast Transmitters; Radio Receiver Apparatus; Apparatus and Generators; Storage Batteries and Auxiliary Equipment; Radio Laws and Regulations; Appendix.
 It is extremely important for the radio man who contemplates taking an examination for a government radio license that he be thoroughly familiar not only with the theory involved in radio reception and transmission but also be distinguished with commercial apparatus which is used only in his theory.
 This is the only publication which gives the exact information for a government radio license that is given in the practical man from one who is immediately in radio reception and transmission but also be distinguished with commercial apparatus which is used only in his theory.
 This is the only publication which gives the exact information for a government radio license that is given in the practical man from one who is immediately in radio reception and transmission but also be distinguished with commercial apparatus which is used only in his theory.
Your Price \$1.89

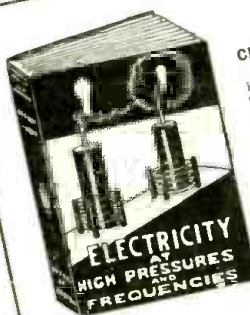

Electricity at High Pressure and Frequencies
 By HENRY L. TRANSTROM
 Cloth covers, size 5 1/4 x 7 1/2 inches, 141 illustrations, 265 pages.

High pressure and frequency phenomena in electric circuits constitute a field of activity quite foreign to most students and practitioners of radio and electricity. The apparatus and insulators become apparent conductors under the influence of high-voltage alternating currents, and the insulation which is both insulating and conducting. He treats his study which is both instructive and entertaining.
 In this standard work on the more familiar field of "commercial" currents and frequencies. He treats his topic without recourse to mathematics, every type of apparatus, theory is followed by descriptions of the results of generating equipment, including Tesla and Oudin high frequency coils, complete construction details are described by the author. Myriad types of vacuum tubes are illustrated and described. This book is recommended to the earnest student of radio and electricity.
Your Price \$2.33

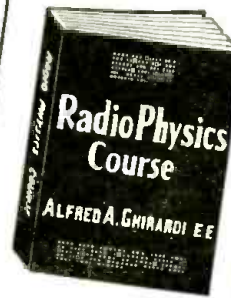

Radio Physics Course
 (Second enlarged edition)
 By ALFRED A. GHIRARDI
 Cloth covers, size 7 1/2 x 9 1/4". 992 pages, 552 illustrations, numerous tables

The finest and most popular book on radio and electricity. Each subject is clearly discussed, with the aid of dozens of excellent drawings. Here are the chapters in this revised edition: Radio Broadcasting Systems; Sound, Power and Music in Radio; Electrical Units and Circuits; Radio Theory; Electric Currents; Induction and Capacitance; Magnetism and Electrical Circuits; Radio Instruments; Condensers; Alternating Current; Vacuum Tubes; Superheterodyne Receivers; Elementary Study of the Receiver; Loud Speakers; Automobile and Aircraft Radio; Super-Wave Reception; Television; Training and Servicing; Sound Motion Pictures; Appendix.
Your Price \$3.89

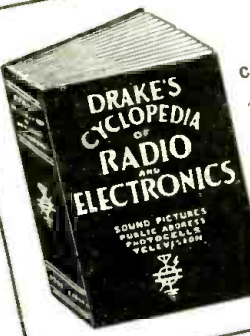

Drake's Cyclopedia of Radio and Electronics
 By H. P. MANLY (Fifth Edition)
 Cloth covers, size 6 x 9 inches, 1048 pages, 1178 illustrations, 130 tables, 105 graphs.

The new, 1933 edition of this now very well-known volume, "Drake's Cyclopedia of Radio and Electronics," is now available. It includes in this latest edition, all the latest information on public address, sound, sound reproduction, television, and phonographic records, and includes information on radio transmission and reception. The new tubes and the new electrical details are treated in a concise and readable form. Every technical detail is available for the reader no longer used in the dark of topics covered by this reference work. The keynotes of radio and electronics, the most complete Cyclopedia available, is the finest book for the technician who wants to get accurate technical information in the shortest possible time.
Your Price \$4.88



Principles of Radio Communication
 By J. H. MORECROFT, Professor of Electrical Engineering, Columbia University
 Cloth covers, size 9 1/2 x 6". 988 pages, profusely illustrated.

This book is the radio classic by the dean of radio. It covers the art of radio as no other book does. The chapters are as follows: Fundamental Ideas and Laws; Resistance—Inductance—Capacitance—Blending; Laws of Radio; Oscillation Circuits; General Principles of Radio Communication; In Typical Circuits; Vacuum Tubes and Their Operation; Telegraphy; Continuous-Wave Telegraphy; Index; Television; Antennas and Hauling; Amplifiers.
 Perhaps the most important single recommendation which we can make for this volume—the radio man's "bible"—is that it is the new, 1933 edition. In other radio publications he has been brought right in the entire field of abbreviated common—buy it. If you want a real reference book on the subject covering the broad field of radio theory, both receiving and transmitting.
Your Price \$7.35

NEW LOW PRICED RADIO BOOKS

Here are 13 new, up-to-date books on every conceivable radio subject, just published. Modern in every sense. All books uniform from 64 to 72 pages; 50 to 120 illustrations. All books are written by well-known radio authors. Order all your books by number.

- | | | |
|--|--|--|
| No. 1 RADIO SET ANALYZERS, by L. Van Der Mel | No. 6 BRINGING ELECTRIC (RADIO) SETS UP-TO-DATE, by Clifford E. Denton | No. 11 HOW TO BUILD AND OPERATE SHORT-WAVE RECEIVERS, by the Editors of SHORT WAVE CRAFT |
| No. 2 MODERN RADIO VACUUM TUBES, by Robert Hertzberg | No. 7 RADIO KINKS AND WRINKLES (for experimenters), by C. W. Palmer | No. 12 HOW TO BECOME AN AMATEUR RADIO OPERATOR, by M. F. Eddy |
| No. 3 THE SUPERHETERODYNE BOOK, by Clyde J. Fitch | No. 8 RADIO QUESTIONS AND ANSWERS, by R. D. Washburne | No. 13 POINT-TO-POINT RESISTANCE MEASUREMENTS, by Clifford E. Denton. |
| No. 4 MODERN RADIO HOOK-UPS, by R. D. Washburne | No. 9 AUTOMOBILE RADIO AND SERVICING, by Louis Martin | PRICE PREPAID EACH BOOK \$.45 |
| No. 5 HOW TO BECOME A RADIO SERVICE MAN, by Louis Martin | No. 10 HOME RECORDING AND ALL ABOUT IT, by George J. Salliba. | PRICE PREPAID FOR ALL 13 BOOKS \$5.20 |

HOW TO ORDER

We cannot ship C. O. D. Our prices are net, as shown. Some of the books sent prepaid (in U. S. only). Those that are not thus listed will be shipped by express collect if sufficient postage is not included by you.

RADIO PUBLICATIONS

245-S Greenwich St., New York City

ORDER DIRECT FROM THIS PAGE



Short Waves in 1954

An Editorial By HUGO GERNSBACK

• JUST about twenty years ago short waves began to be recognized, chiefly because of the amateur activities below 200 meters. There was, to be sure, no phone transmission in those days, because broadcasting did not come along until about 1921; and whatever phone transmission there was, occurred on the higher waves.

Short waves, of the more ambitious variety, were confined to the research laboratory, where they stayed for many years.

What will short waves do twenty years hence? We who look at short waves today are apt to be astonished at the tremendous range of the new art and the extent to which it has advanced in a few short years; and, if the future progress even approximates that of the past twenty years, we certainly would be most astonished to see the developments of twenty years hence. But I sincerely believe, and, as a matter of fact, I have reasons to know, that the next twenty years will eclipse everything we have done up to now, by far. Whatever else I may say here—and it may be checked in 1954—I am certain the prediction will fall far below the mark, and that many important, astonishing inventions and applications will have been made beside those which I describe here.

Foremost, of course, there is *television*. We cannot think of television without short waves. All radio engineers and scientists seem to be convinced that, if the missing link in television is discovered and a new instrumentality is found, the television emissions will most likely be on ultra-short waves. Most certainly, they will be below 200 meters.

Next, and most important, we have to consider the *power* of short-wave transmitters. The most powerful station today only emits 40 kilowatts; this is a comparatively small amount of power. There is no reason to doubt that, in the future, stations will use a million watts and over, and most of the large and important stations will use this power and perhaps a great deal more. What does that mean to you as a listener? First of all, it will do away with *fading*; and a distant station, as far as 10,000 miles away, will come in like a *local* on your set, even if that set is only of the two-tube variety. With such power behind it, no one will need a ten- or fifteen-tube set because, by that time, a one- or two-tube set—at most, three tubes—will give you so much volume on the loudspeaker, you would not think of using more tubes.

The chances are, that the large broadcasters, for business and political purposes, will broadcast the same program in three or four languages on the same wavelength. This statement should not astonish you because, several years ago, the Columbia Broadcasting System successfully broadcast both speech and television impulses on the same wavelength. So, if you are a distant listener, and you get the four programs all on the single wavelength, you will have a selector switch which makes it possible for you immediately to listen to the language you wish to hear, to the exclusion of the others. Thus, for instance, a station in Great Britain may broadcast in English, French, German and Spanish, all at the same

time, using four announcers to broadcast the same program. The reason for this statement is that, since short waves are international, the various countries already now recognize the fact that in short waves we possess a comparatively cheap instrument to mould world opinion.

We will have mail planes traveling between Europe and the United States in from four to six hours, flying through the stratosphere. No human being will be on board; the mail planes will be all machinery, and every available inch of cargo space will be taken up by mail and first-class parcel post. The steering, landing, dispatching, etc., will all be done by short-wave impulses, by the new art called radio-telematics. Radio-controlled airplanes have been flown in the past; but short waves are the key to the safe operation of such planes in the near future.

Then, of course, we will have the long-awaited radio set which delivers your *newspaper*. This too, is to be done by short waves. At this point it is interesting to note that the Radio Corporation of America has just announced a country-wide *point-to-point* facsimile telegram delivery system. Hereafter, instead of sending a telegram in the usual manner, you will write it out in longhand or typewrite it, and you can incorporate in it all sorts of sketches, technical or otherwise. You then send the telegram in the usual manner, and it will be delivered with your own signature appended to it, in facsimile; or you can send an entire letter, handwritten or otherwise, in facsimile, and it will be delivered *exactly as you have written it*.

The same principles are made use of in the *radio newspaper*. This, by the way, is being described in an illustrated article by myself in the April issue of RADIO-CRAFT magazine. The radio newspaper receiving set is entirely automatic; it embodies a special short-wave set, which is placed in operation by clockwork at, say, 2 o'clock in the morning, when the special facsimile signals begin to arrive. A roll of paper, stretched taut, slowly moves over several rollers, while a special mechanism (comprising a compressed air jet and a special ink bottle, controlled by a modulated electromagnet) blows ink vapor on to the paper surface. Duplex devices are so used that the paper is printed on both sides at once. As the signal comes in, the paper advances slowly. A carriage, like a typewriter, moves back and forth, many times a minute, and printed words, sketches, photographs, etc., appear as by magic on the paper.

When, in half an hour, all the printing is finished, the paper is then automatically folded by your radio set and delivered into a rack, where you find your newspaper next morning. Of course, this will not be a bulky journal such as you have now; it probably will be either four or six pages of "spot" news, important announcements, photographs of disasters, or other important occurrences in the news. The price will be very low; certainly not more than charged for the present-day newspaper. The cost of disseminating the news is borne by the short-wave broadcasters, who will get revenue from the "ads" that appear in your *radio newspaper*.

SHORT WAVE CRAFT IS PUBLISHED ON THE 5th OF EVERY MONTH

This is the April, 1934, Issue—Vol. IV, No. 12. The next Issue Comes out April 5th

Editorial and Advertising Offices - 96-98 Park Place, New York City

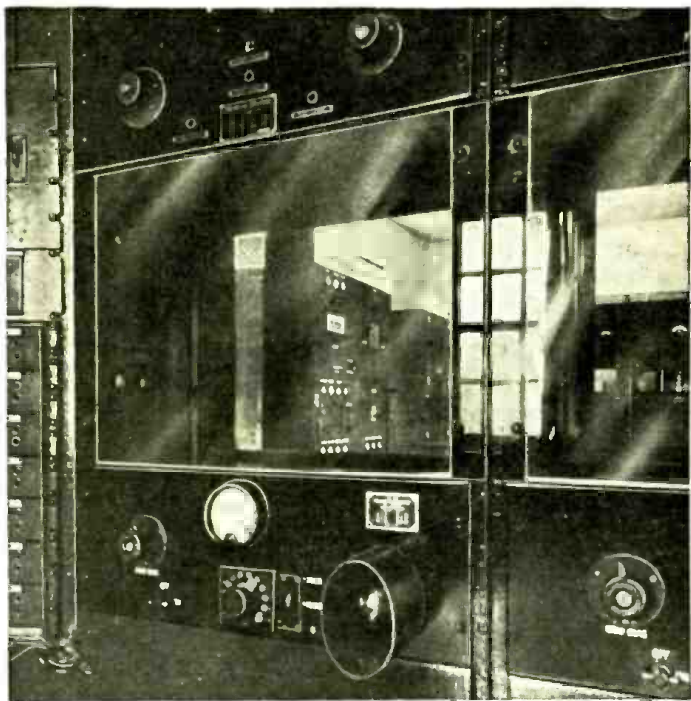

View of short-wave station, W2XE, at Wayne, N. J., through a window in the control room.

● MANY Eastern visitors to the beautiful lake country in the vicinity of Wayne, N. J., where the powerful transmitter of WABC is also located, have undoubtedly been impressed with the unusual double-inverted pyramid steel mast, nearly 800 feet high, which marked a new venture a few years ago and which was first tried out at this station by the Columbia Broadcasting System. This idea of using a two pyramid-type steel lattice masts, placed base to base and the whole metal structure serving as the antenna, well guyed in position by a set of specially insulated guy cables was original with the CBS engineers; since that time it has been widely adopted here and abroad.



Close-up of the transmitter panels of W2XE, "CBS" high frequency station.

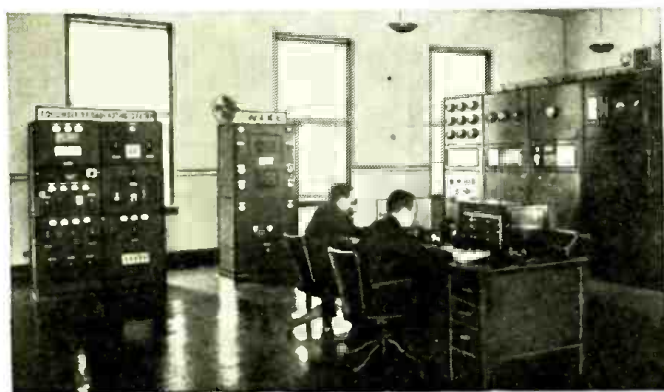

General view of the W2XE transmitter, showing operators' desks.

W2XE is the high frequency experimental relay broadcast transmitter owned by the Atlantic Broadcasting Corporation and carrying the regular Columbia Broadcasting System programs. This transmitter was placed in service March 1, 1933.

During the short time that this transmitter has been in operation, hundreds of verified reports concerning its reception have been received from the following countries: Argentine, Australia, British Guiana, (Continued on page 746)

W2XE

The Short-Wave Voice

Of the Columbia Broadcasting System

A powerful short-wave voice that has been "heard around the world" is that of W2XE—the high frequency experimental broadcast transmitter operated by the Columbia Broadcasting System at Wayne, N. J. The programs from WABC are relayed through W2XE on the time and frequency schedule given herewith.

W2XE—OPERATING SCHEDULE			
Current New York Time	Frequency	Wave Length	
11 A.M. to 1 P.M.	15,270 kc.	19.6 meters	
3 P.M. to 5 P.M.	11,830 kc.	25.4 meters	
6 P.M. to 11 P.M.	6,120 kc.	49.0 meters	



The transmitting equipment of W2XE is housed in this building at Wayne, N. J., about 25 miles from New York.

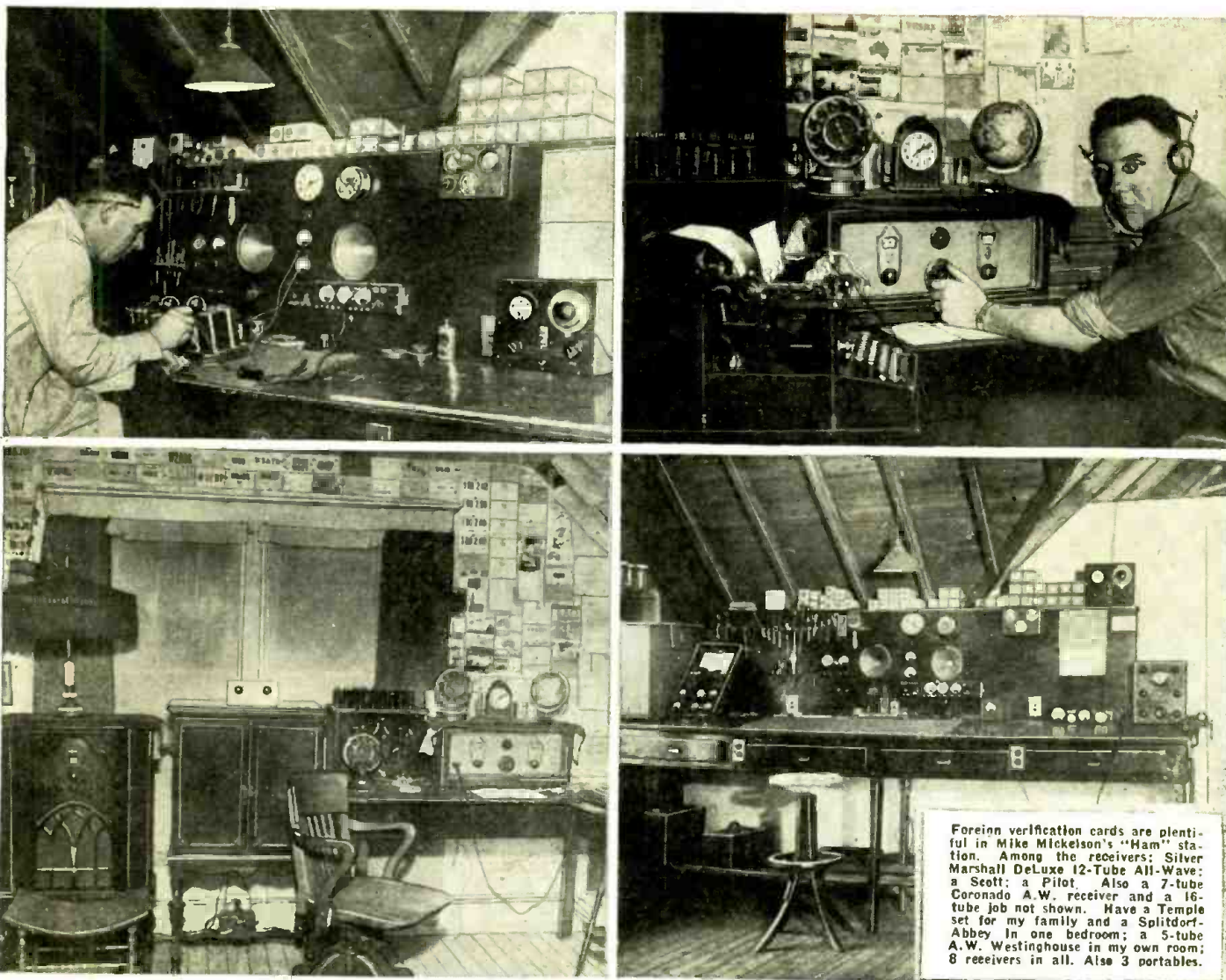

Foreign verification cards are plentiful in Mike Mickelson's "Ham" station. Among the receivers: Silver Marshall DeLuxe 12-Tube All-Wave; a Scott; a Pilot. Also a 7-tube Coronado A.W. receiver and a 16-tube job not shown. Have a Temple set for my family and a Spittdorf Abbey in one bedroom; a 5-tube A.W. Westinghouse in my own room; 8 receivers in all. Also 3 portables.

Radio "Cop" Has A-1 Station

● PATROLMAN Mike Mickelson has in his home in Minneapolis, Minn., one of the finest experimental amateur stations in the northwest—one constructed principally in the beginning from many odds and ends, torn down and rebuilt countless times with a minimum of expenditure.

When it began, in 1912, with the first little "rock-crusher" of a transmitter built by Mike and his companion, Arnie Rufsvold, books on such subjects were as rare as are radio announcers who can feel calm about the merits of a shaving soap or a new itch powder.

But Mike and Arnie, then attending Corcoran school, gleaned what they could from available books and magazines; and discovered the rest, as did the other early "hams" of radio, from tearing down and rebuilding.

It was many weeks before they completed their first successful transmitter—the little "rock-crusher" that sputtered out its messages from a set built of scavenger-party junk and an old fivver spark coil.

They "talked" with another "ham" in St. Paul. The 10 miles wasn't much distance; but to them, it was something never to forget.

One of the "crack" short-wave experimental stations in this country is owned by Mike Mickelson of Minneapolis, Minn. He is operator and chief dispatcher of the Police Headquarters of his home city, but the experimental "home" station here illustrated is the one he loves the best.

More weeks of tearing down and rebuilding; a second station, at Nichols, down in the Minnesota river bottoms.

The radio bug infection was deep; parents were fretful. Not particularly interested in seeing sparks jump from coils, their greatest worry was electrocution or a fire.

As parents have found before, there wasn't much to do about it.

But 1917 came, and war. Mike, in the army and later in the navy, was separated from his radio. On shipboard, his only contact with the old hobby was an occasional hour with the ship's "Sparks"—the operator.

After discharge, shifting from one job to another, it was difficult for Mike

to assemble his wires, dry cells and wet cells, and fiddle with sparks and coils.

He punched cattle and sold coffee, worked in a bag factory and at odd jobs. But what money he saved, he put into equipment.

Crystal sets drew his attention. A new thrill was fiddling with the little wire "tickler" on the diminutive crystal and pulling in stations without power or even antenna of considerable size.

Even then, parts were difficult to get, and costly. He began making his own.

In 1926, he completed a one-tube short-wave adapter known as the Flewelling type which converted an ordinary receiver into a super-sensitive short-wave set.

He pulled in G5SW, at London, for his first real distance try. Building others, he recorded VK2ME at Sydney, Australia, at 2 o'clock one morning. He sold some of his converters to friends, and gave others away to more intimate cronies.

His most powerful short-wave set was one of 16 tubes, having an output of approximately 15 watts. For one built largely of cast-off equipment, its efficiency was remarkable.

(Continued on page 752)

3/4 METER Transmitter and



"Charlie" Kostler with the 3/4 meter portable, battery-operated transmitter, which proved its powerful transmitting abilities in numerous tests.

The three-quarter meter portable transmitting and receiving set here described was very satisfactorily demonstrated before the editors, the portable transmitter having been carried through the city streets for a number of blocks, while the voice was picked up in the laboratory. The transmitter at times was located under the steel elevated railroad structure and in other unusual locations.

by steel building structures. No serious difficulties have been encountered with the type equipment employed, neither were there any detrimental effects noticeable, due to direction or location of the transmitter. Actual tests were conducted on the 18th floor of the Columbia Broadcasting System Building in the heart of Radio City (located in New York City).

Similar tests were made in the *New York Times* newspaper building, while successful tests were also conducted by a New York Police Department "Scout-car." In these tests speech was received perfectly up to distances of one mile and while the car containing the 75 c.m. transmitter was in rapid motion.

The authors offer to SHORT WAVE CRAFT readers and experimenters the details of the apparatus employed and the circuits used. The possibilities are limitless and the authors can truthfully say that the thrills encountered were certainly worth the time spent in research, which extended over a period of several months.

In past issues of SHORT WAVE CRAFT descriptions have often been given of different type transmitters and receivers for *ultra short-wave* work but thus far nothing definite has been accomplished in proving the actual possibilities to be gained in operating at these *ultra high frequencies* or wavelengths of 75 centimeters (3/4 or 1 meter). From the

authors' experiences, it can be truthfully stated that severe working tests were actually made and not just mere theoretical assumptions offered. Various types of circuits have actually been tried with but very little efficiency regarding and taking into consideration the mileage to be covered, plus the power input used, as well as stability and directional effects at these extremely high frequencies. Greater fidelity is gained in comparison with the lower frequencies, such as freedom from atmospheric disturbances and extreme fading.

Circuit of U.H.F. Oscillators

In figure 1 we have a circuit diagram of the *ultra high frequency* oscillator; the type circuit employed has proven to be exceptionally stable. The vacuum tube used as the oscillator is the type 30. The inductance is L-1 and L-2 and the condenser C— represents the oscillator tank circuit, where L-1 and L-2 are 1/4" copper tubing 12" in length and spaced 3/4" apart. The "tank" tuning condenser, which happens to be a fixed capacity with clips, is adjusted by sliding it along the inductance L-1 and L-2 for the purpose of *tuning*.

The vertical antenna employed consists of a 40" (forty inch or about 1 meter) length of 1/4" copper tubing mounted vertically and held secure by means of small standoff insulators, fastened to a 40" (1 meter) length of wood,

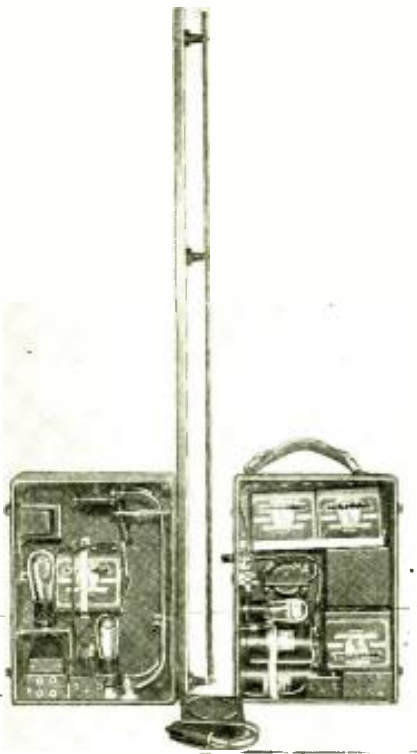

A peek at the "innards" of the 3/4 meter phone transmitter; it weighs but 15 lbs. with self-contained "power supply".

● EXCELLENT results have been accomplished in the *ultra short-wave* spectrum on a wavelength of 75 centimeters, with a power expenditure of less than 1 watt; the actual range covered was well over a mile during tests conducted in the city, the portable transmitter being at times surrounded

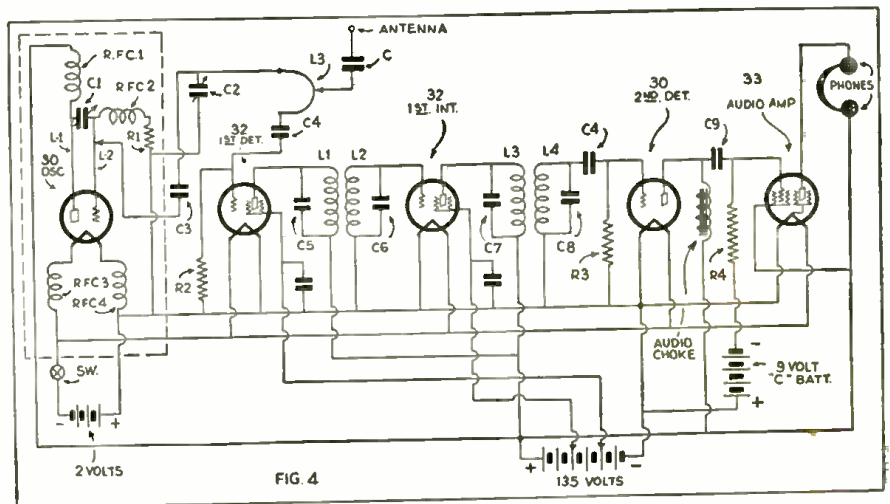

Wiring diagram of the 3/4 meter "Receiver", used in the highly successful demonstration tests.

Portable Receiver

By CHARLES KOSTLER

Short-Wave Consultant, Assisted by DONALD CONVERSE



approximately $1\frac{3}{4}$ inches; this prevents the antenna from swinging. The antenna clip is adjusted along L-1 to such a position that when the plate current milliammeter (M1) draws more current, this will be an indication that the antenna is being energized; when bringing the hand near or touching the antenna at various lengths this will cause a deflection in the milliammeter (M1), showing that the transmitter is oscillating properly. The radio frequency choke coils used in this circuit are rather critical; RFC1 and 2 are wound with 50 turns of No. 20 D.C.C. magnet wire on a bakelite form (tube) 2" in length and $\frac{1}{4}$ " in diameter. R.F. C. 3 and 4 are wound with 50 turns of No. 28 D.C.C. wire on a bakelite form (tube) 2" in length and $\frac{1}{2}$ " in diameter. The milliammeter used in this transmitter has a scale deflection from 0-100 milliamperes. The bias resistor R-1 is 15,000 ohms, R-2 100,000 ohms, R-3 is 500 ohms. A type 33 pentode tube was chosen for the modulator and provides sufficient output to modulate the 30 tube. The type 30 tube is also used as a speech amplifier. The constant current choke or impedance (IMP) may be any good type 30 henry choke.

Microphone Transformer

The microphone transformer T-1 may be for either a single or double-button mike. The transformer T-2 may be any good make of audio transformer, with a ratio of approximately 5 to 1. The switch (SW) is of the toggle type and controls the tube filaments, as well as the microphone current.

The filament battery supply is composed of $1\frac{1}{2}$ volt portable type dry cells, while the plate supply employs four 45-volt portable type "B" batteries.

The general arrangement of the portable transmitter is shown in the photo-

graph. In arranging the various parts make all connections as secure and as direct as possible.

In adjusting the oscillator to the proper wavelength, a Lecher wire system is used, consisting of two $\frac{1}{4}$ " copper tubes 40" in length and separated 3" apart. Figure 3 illustrates this arrangement; by coupling the rods loosely to the inductance L-1 the wavelength may be measured in centimeters by means of a centimeter scale. See figure 3. The case that houses the portable transmitter measures 12" in height, 9" in width by 6" in depth; the arrangement of the parts used are left to the builder.

The 75 Centimeter Double-Detection Receiver

Experiments were carried on with various type circuits to produce a receiver that would operate efficiently, allowing freedom from excessive body capacity effects. Many different super-regenerative circuits were tried but the noise-level generated by the low-frequency oscillator was unhearable, so it was decided upon to employ the super-heterodyne principle. The circuit shown in figure 4 suited the purpose most efficiently. It will be noticed that the oscillator is similar to that used in the transmitter, the only change being



Donald Converse tuning in the $\frac{3}{4}$ meter phone signals on the battery-operated receiving set, which is a superhet.

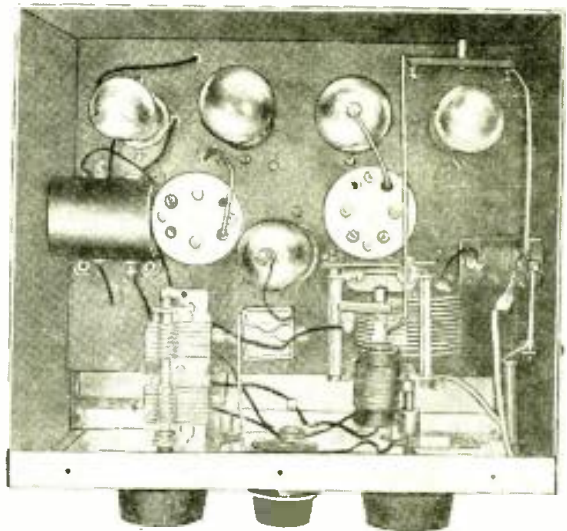

Above, we have a top view, looking down into the $\frac{3}{4}$ meter battery type receiver, used in the demonstrations before the editors of this magazine.

that instead of using copper tubing, No. 12 tinned copper wire is used, the length being the same as that shown in figure 1; the condenser C-1 is in this case variable, and is used as the oscillator tuning unit and is quite uniform over the entire tuning range. The RF

(Continued on page 751)

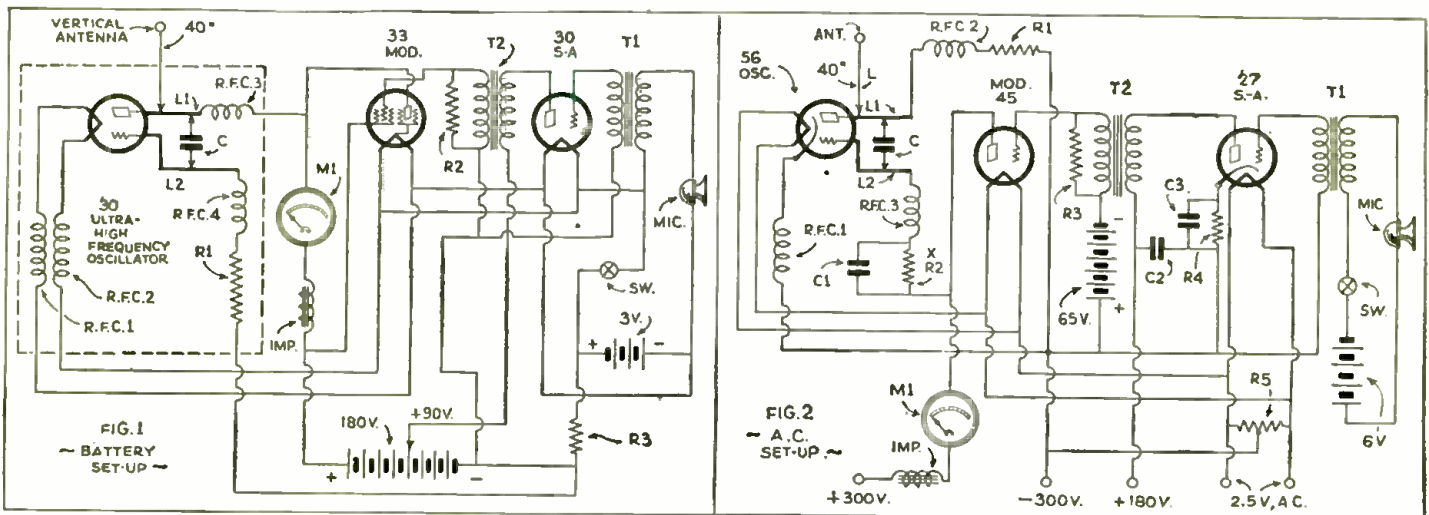

Diagram, above, at left, shows simple hook-up of the $\frac{3}{4}$ meter, battery-operated Transmitter. Right-hand diagram shows $\frac{3}{4}$ meter Transmitter designed for operation on 110 volts, A.C.



An ideal source of "A" current supply for the TETRADYNE is the new 2-volt "Air Cell" battery.

● EVER since short waves became popular, inventors have tried their best to do away with the nuisance and additional labor involved in changing plug-in coils.

Short-wave "fans," and particularly the professional ones, take little interest in switching arrangements. They know from experience that when it comes to maximum efficiency, the plug-in coil method cannot be beaten. They know that switching methods occasion certain losses, and for that reason the real dyed-in-the-wool short-wave "fan" will only use plug-in coils. Yet, these coils have their disadvantages. It is admitted by all of us that plugging in and out the coils is not only time consuming, but often makes you miss signals. Secondly, the wear and tear of the coil itself, sockets, contacts, etc. (also the possibility of poor contacts), is not to be lost sight of.

Bearing these things well in mind I have, for a long time, wondered how, as the saying goes, we could eat our cake and still have it. The present *Tetradyne* idea (*Tetra*—Greek=four; *dyne*—Greek=power), I believe, solves the problem in a rather novel manner.

All Coils Are Stationary

In the *Tetradyne*, which I describe here, the plug-in coils are used, but they are stationary! You no longer plug them in or out. Yet, every plug-in coil is ready instantly, and there is no switching, as we know the term, in this set. Everything is stationary, and there are no dead-end or other similar losses.

The *Tetradyne* receiver really is a combination of four two-tube sets into one single receiver. It will be seen from the circuit diagram, as well as the photographs, that I use four tuning dials, one dial for each wave-band. Each set has its own tube, its own condenser, its own antenna, its own ground, etc., all the way through, and the set makes use of a single amplifier, i.e., the '33 tube.

Set Uses 4—30 and 1—33 Tubes

Let us now see what happens: The set, as you will note, uses four battery

tubes of the type '30 and one type '33. The receiver is ideal for use with the new *Air Cell* battery. The set uses four regulation coils from 16 to 225 meters. Each coil, however, is in its place and is never taken out. If you wish to listen to the 16 to 25 meter band, that is Coil No. 1, you use the first dial. You throw the switch underneath the dial which lights the filament only of the first tube as well as the '33 amplifier tube. The three other tubes are not in the circuit. You now have an ordinary two-tube set, which works on the band from 16 to 25 meters.

If you wish to listen to the waveband from 25 to 50 meters you flip the switch under the second dial and throw the switch under that dial. This instantly gives you the use of the 25 to 50 meter band to the exclusion of other bands. Note particularly that there is no so-called switching arrangement in this set. The four switches are ONLY to cut in or out the filament, and have

Now the FOUR

The dream of every short-wave fan has at last been realized in this latest invention of Mr. Gernsback's—the TETRADYNE — which provides four distinct detector stages in one receiver, each stage having its own tuning condenser and coil. By merely flipping any one of four switches controlling the tubes in the different stages, each stage covering one distinct wave band, you are ready to instantly tune for stations in the "desired" stage; all without having to change plug-in coils.

nothing whatsoever to do with the tuning arrangement, with the plug-in coils, or with their connections.

Dial No. 3 covers the wavelength from 50 to 100 meters, and Dial No. 4 covers the wavelength from 100 to 225 meters.

Each Band Available at Flip of Switch

For the first time, therefore, we have here a set where the four bands can be thrown in instantly, at the flip of a switch, and it now becomes possible, without fuss and without time loss, to listen in to the same station as it comes in on different wavelengths, as, for in-

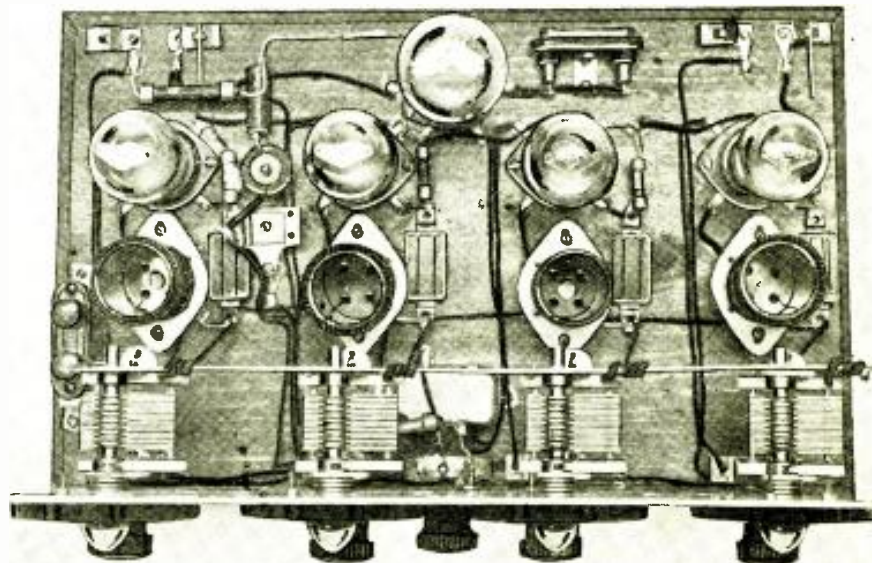

Top view of the TETRADYNE, showing the four detector stages and the "common" audio amplifier tube.

TETRADYNE!



RECEIVERS IN ONE • By HUGO GERNSBACK

stance, several of the English stations and some of the American stations which broadcast simultaneously on various wave-bands.

Not only this, but there are other and obvious advantages. In the first place, there is such a thing as "overlap" of bands. For instance, a station may come in on Dial No. 1 at 95. The same station may come in on Dial No. 2 on 5 or 8 with better results, due to your using a different coil. This is, of course, true with all short-wave sets, but the point I wish to make is that by using the *Tetradyne* instant comparison can be made, and sometimes it is best to use one plug-in coil in preference to another, because often better results are had in this manner.

Only One "Regeneration" Control

There is only one *regeneration control* to the set, which is common to all tubes. This will be readily seen by studying the diagram. Separate regeneration controls for each tube could, of course, have been incorporated, but I believe this would have made the set somewhat too cumbersome and too complicated, and I believe it will be found that a single regeneration control in the center of the panel is best for all-around use.

(Continued on page 755)

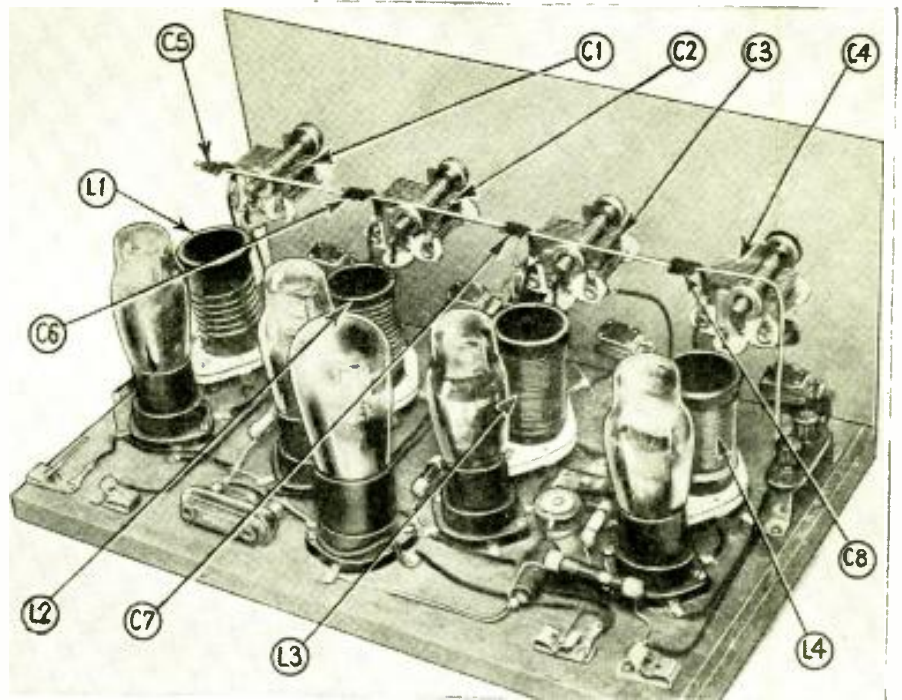

Looking at Mr. Gernsback's newest short-wave receiver, the TETRADYNE, from the rear.

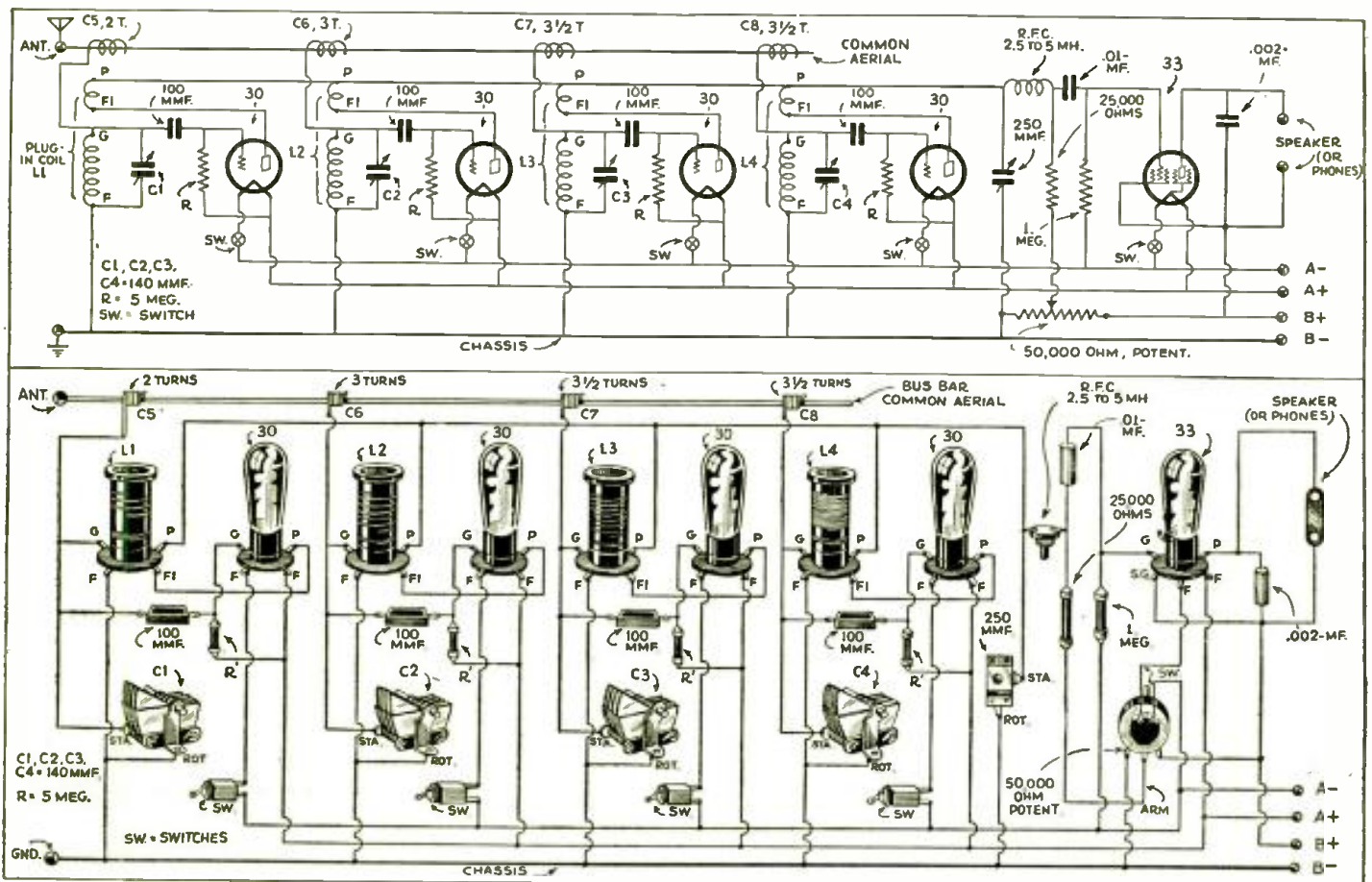

You will find it a very easy matter to build Mr. Gernsback's newest "brain-child"—the TETRADYNE—by following the picture diagram given above. The schematic diagram is also given above.

A Good 14-Tube Receiver

A Special Super-het with Pre-Amplifier — Part 1

By Frank D. Andrews



Front view of the specially designed 14-tube superheterodyne. Top center—band selector, or oscillator, controlled by knob under scale; left dial—control of radio frequency gang; right dial—station selector, or band spread; four small knobs—trimmers of radio frequency condensers; knobs at bottom—left to right, 1 automatic resonance control, 2 screens of radio-frequency detectors, 3 cathodes of radio frequency tubes, 4 gain of intermediate tubes connected in screens, 5 tone control, 6 audio output control; left bottom—jack for milliammeter; right bottom—main switch.

● PUBLIC demand has encouraged manufacturers, large and small, to increase the efficiency and precision of parts of every kind to fill every radio need, so that now, the non-technical and the technical radio listener, together with those interested in scientific development, and the amateur, may explore new fields in the art of improvement with very gratifying results. Good practical apparatus is no longer shelved in the laboratories for trade reasons as in the past; jobbers in all parts of the country are carrying larger stocks of complete standard lines; and tube manufacturers are doing their best to render the finest prod-

ucts for general distribution.

These encouraging facts greatly stimulated my patience in developing a modern short wave receiving instrument which would render the highest standard of uniform service.

The design of the receiving instrument here presented, we believe, for the present, offers a basic "yardstick" in your own hands for comparison in obtaining the finest reception of short-wave programs and communications which you have yet heard.

At the present milestone, to us, this means a practical instrument for high frequencies, meeting all city conditions, noiseless, simple, smooth and flexible in the hands of any operator.

Specifications

- Our specifications called for a set which was in the first place, not a toy; something that would play all the principal stations of this continent in California constantly all day and night with generous local volume without forcing it, and without constant moni-

toring. Fading, and distortion from phase fading had to be eliminated. Such a receiver must play W8XK uniformly as well on 21,540 kc. as it does on 6,140 kc. European stations of equal power must come in with the same volume and regularity under relative ionosphere conditions, as do the stations of this continent. The audio frequency quality on all reception shall be free from distortion, with a flat response curve from 70 to 10,000 cycles.

A receiving instrument must be ultra-sensitive in Southern California (where writer's laboratory is located) to accomplish such results, and step by step we improved the sensitivity to where the present receiver in the heart of the city on a 100 foot aerial will respond equally as well as our first endeavors out in the country, 20 miles from town on a 500 foot aerial!

Amateurs of the first and second districts are now heard R8 to R9 from early morning until the "fade-out" at evening, on the twenty meter band.

Rigid Tests for this Receiver

All development was done in a busy city location adjacent to main highways and car lines, hospitals, and movie studios. Two sets have been kept on the air at all times so one is a comparative standard for the other. When reception is poor, we can then place the blame. If a change of apparatus or circuit is suggested, we can make it on one of the twins, and check against the other for a period of time.

If a practical improvement is found we add it to both receivers; however, they have been operating for the past sixty days without alteration. For six months these same sets have been in the hands of many operators, and as everyone seems to have run out of suggestions, I believe they are final for quite some time to come.

My associate is a very critical patron of radio, deeply interested in scientific improvement. Recently, while abroad

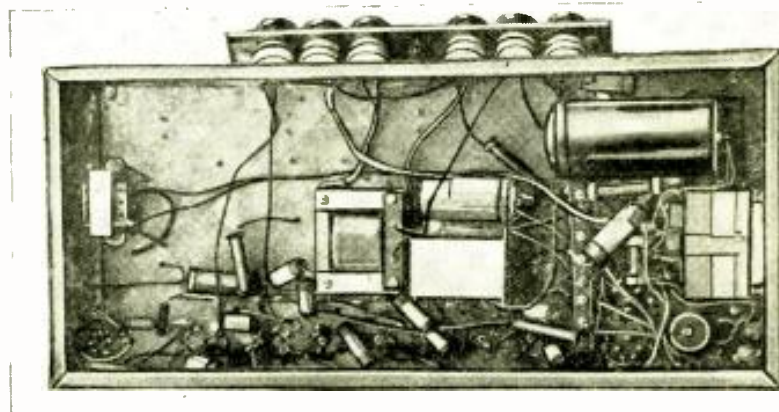
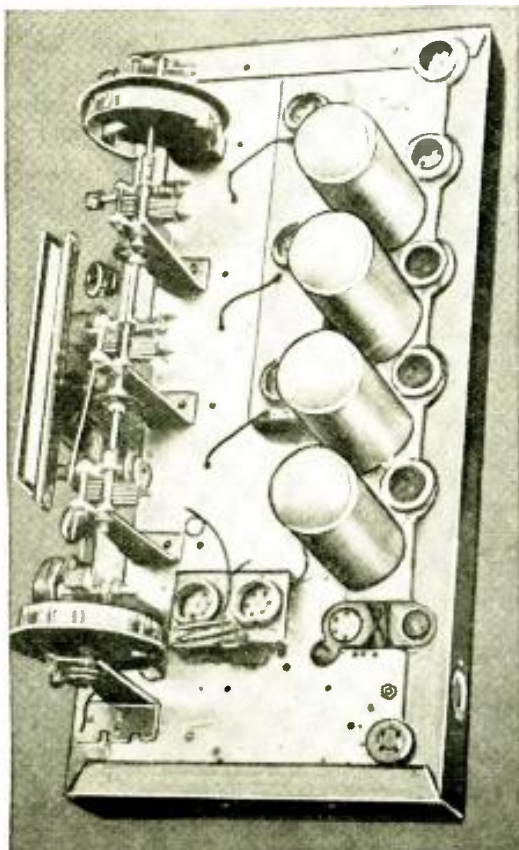

Photo, at left, shows general view of the 14-tube receiver chassis as designed and built by the author, and with which very exceptional results have been obtained. Photo directly above shows bottom view of the 14-tube superhet receiver chassis.

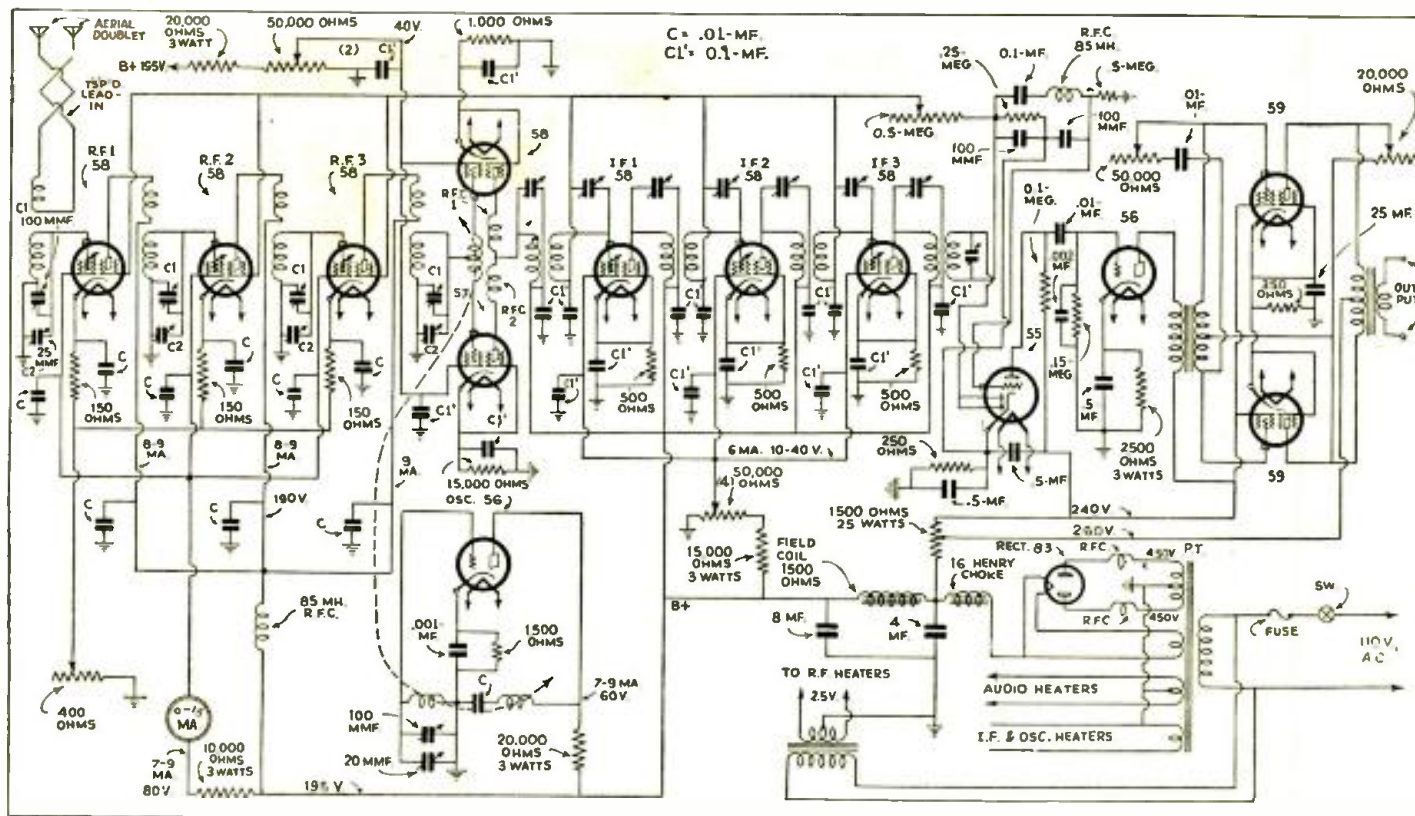

Wiring diagram of the 14-tube receiver—a superheterodyne with pre-amplifier ahead of the first detector, is shown above.

and in New York he made a very comprehensive survey of short wave receivers. The knowledge which he has imparted has been a great help. I also consulted every published diagram and treatise on short wave that I could find, and sought the advice of well seasoned engineers for technical data. It has therefore been my privilege to see the practical working result of hundreds of circuit combinations, which I have myself tried.

5 Complete Receivers Built for Test!

More than a score of design features have been set up with respect to the placing of parts and shielding. Five complete receivers were built in duplicate and given "block" tests for months at a time. These sets were all dismantled, junking much costly machine work. Finally the design here presented was built up from the experience gained from the first five.

If you are interested in building this instrument, it will not be found costly, but we cannot urge you too strongly to remain with the specifications as laid out. If you have any changes which you think will work better, add them after the receiver is completed and operating so you have some means of comparison. Too often the experimenter has crystalized ideas which will not dove-tail with new design, until they have been properly adapted to the entire mechanism as a whole.

Technically, short-wave is a relative of long-wave or broadcast frequencies, but the more forgotten about broadcast receiver experience, the better while working on short-wave receivers. The two spectrums depend upon entirely different ionized ceilings for propagation, and even each band of short-wave frequencies is very selective in the ionosphere. Short wave frequencies are as far removed from broadcast fre-

quencies, as the audible spectrum is from the visible spectrum.

S-W Receiver Must be Stable

To reliably "play" short wave broadcasts and copy communications, the receiver must be strictly a precision instrument. Not only shall it be sensitive, but extremely stable in operation. All harmonics and oscillations beyond the desired resonance must be neutralized. Great care in mechanical construction must be employed. Perhaps not so much, if the set were peaked to operate on but one frequency, but here you are required to have it balanced so you may peak it at any desired frequency from 3,000 kc. to 30,000 kc. within a fraction of a minute!

Stability must be such that while the

In this article Mr. Andrews describes the reasons for designing his 14-tube short-wave receiver, some of the interesting results obtained with it and finally—how to build the receiver. Full details are given in the accompanying article. A 3-stage pre-amplifier is used to afford the maximum amplification of those extremely weak "DX" signals. The tremendous amplification of this receiver ensures steady reception at practically all times.

receiver is operating on signals of weak amplitude, the hands may be run through the set in close proximity to coils, condensers, and apparatus, without changing tuning or balance. The chassis or base shall be so rigid that when the receiver is moved about and worked on, that mechanical parts and wiring will not be thrown out of true by springing.

Assuming all these items are well taken care of, there remains three difficult problems that can ruin good short-wave reception. First: sharp tuning is a nuisance, and defeats the most sensitive receiver for consistent results. A receiver must be made broad enough to detect every signal of the weakest amplitude, and yet be selective enough to split at least five kc. at the 6,000 kc. band of 25 kw. power.

Second: even though the automatic volume control was in service, general fading accompanied every transmission and so much so, that it was accepted as a necessary evil. It took a long time to convince me, that in a fade the signal was still on the grid of the pick-up tube. Regardless of how close to zero, it was argued, that signal was still there!

General accepted methods of "curing" this type of fading has been the erection of various (multiple) antenna systems over several acres, spaced from 1,000 to 3,000 feet apart with the receiver so arranged that it will be fed through doublets equally. We have the facilities, and did this with excellent results; however, the question is—what is the fellow in the city going to do about it?

Answer to "Fading" Problem

The only answer is—enough radio frequency amplification to build up the signal so as to trip the radio frequency

(Continued on page 763)

The New "STAND-BY"



By **CLIFFORD
E. DENTON**

Short-Wave Receiver

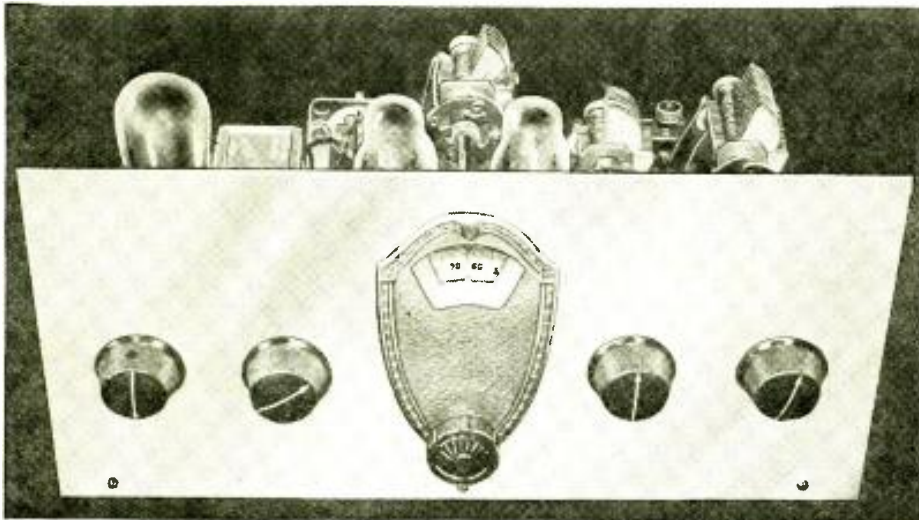

Front view of the new "2-band" Stand-By S.W. Receiver designed by Mr. Denton, in which either of the European broadcast bands are made available quickly by means of two pin-jacks.

● ONE of the most popular receivers to appear in *SHORT WAVE CRAFT* was the Stand-by. This new receiver, while it has several features that make it radically different from the old one, will surely take the reader's eye and it is safe to say that hundreds of set constructors will build this set and obtain the same smooth results as the Author.

Just as the new cars offered for this season differ from last year's model so does the Stand-by. Cheaper construction, high efficiency with reasonably priced parts and greater flexibility of control form the main features.

Frequency Range

The frequency range of this receiver covers the most important bands. Starting at 15 meters, a simple jack switch carries the wavelength response up to 55 meters. The first band stops at 35 meters and the second band starts at 25 meters, thus providing sufficient overlap for real tuning.

Push-Pull Detection

Instead of adding additional stages of amplification before the detector, careful tests were made to determine if there would be any improvement if the detector stage were push-pull. This required the use of an additional tube but the marked increase in selectivity and the smoother regeneration control action obtained made the change thoroughly worth while. One important result is the prevention of R.F. currents flowing in the audio stages.

Regeneration Control

The regeneration control consists of the .00014 mf. condenser connected across the plate coil and controls the amount of current flowing through the plate coil. This results in a very smooth control and its action is such that there is very little tendency to jump into oscillation unexpectedly. It is not neces-

sary to have more than two turns in the regeneration winding as the grid circuit damping is very low. If the regenerative action is too great simply move the turns of the feed-back winding away from the grid coil and after the best position for smooth regeneration control is obtained, drop some collodion on the turn and leave it alone. A study of the circuit and the coil connections will show that the R.F. currents in the plate circuits will aid one another but will cancel out in the center tapped connection made to the plate coupling resistor. (Diagram next page.)

Many short-wave fans have been looking for a receiver which would cover the two principal frequency bands used by European and other short-wave transmitting stations—the new "Stand-By" here described by Mr. Denton supplies this want. It covers the two important bands, the first from 15 to 35 meters and the second from 25 to 55 meters; either band being selected by means of two simple pin-jacks. This set also "sports" a new and powerful push-pull detector stage.

Construction of the Special Coil

The coils for this receiver must be made by the set-builder as they are not available on the market at the present time. A coil of this type is very simple to construct and should offer no difficulties at all. Obtain a piece of 2-inch diameter tubing and have it cut to a length of $3\frac{1}{4}$ inches. Mark off the cen-

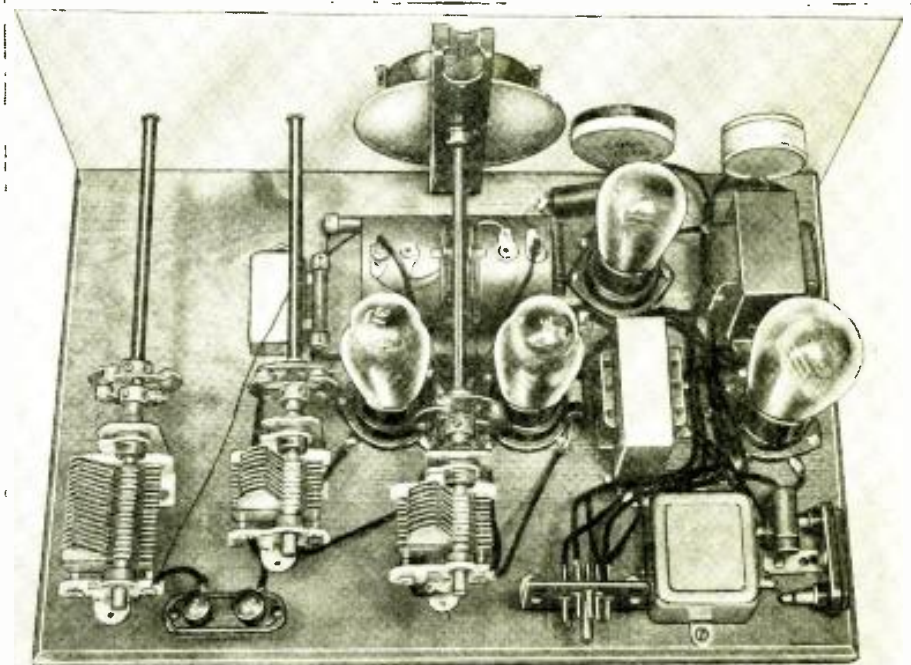

Another view of the new "Stand-By" S.W. Receiver very successfully worked out by Mr. Denton, and providing extremely smooth regeneration, thanks to the "push-pull" detector stage and the method of regeneration control employed.

Denton "Stand-By" Constructional Details

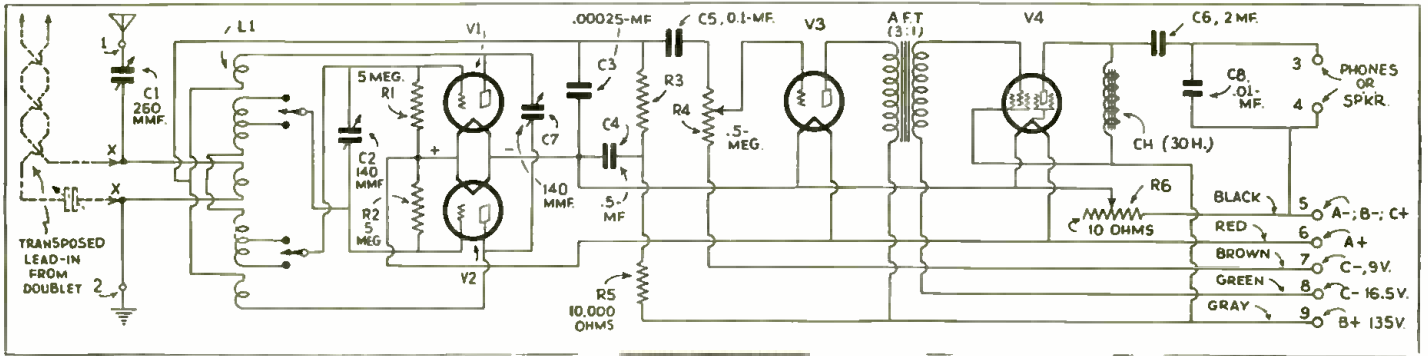

Schematic circuit diagram is given above for Mr. Denton's new "Stand-By" receiver. It features an extremely smooth-working "push-pull" detector stage, with accompanying smooth regeneration control.

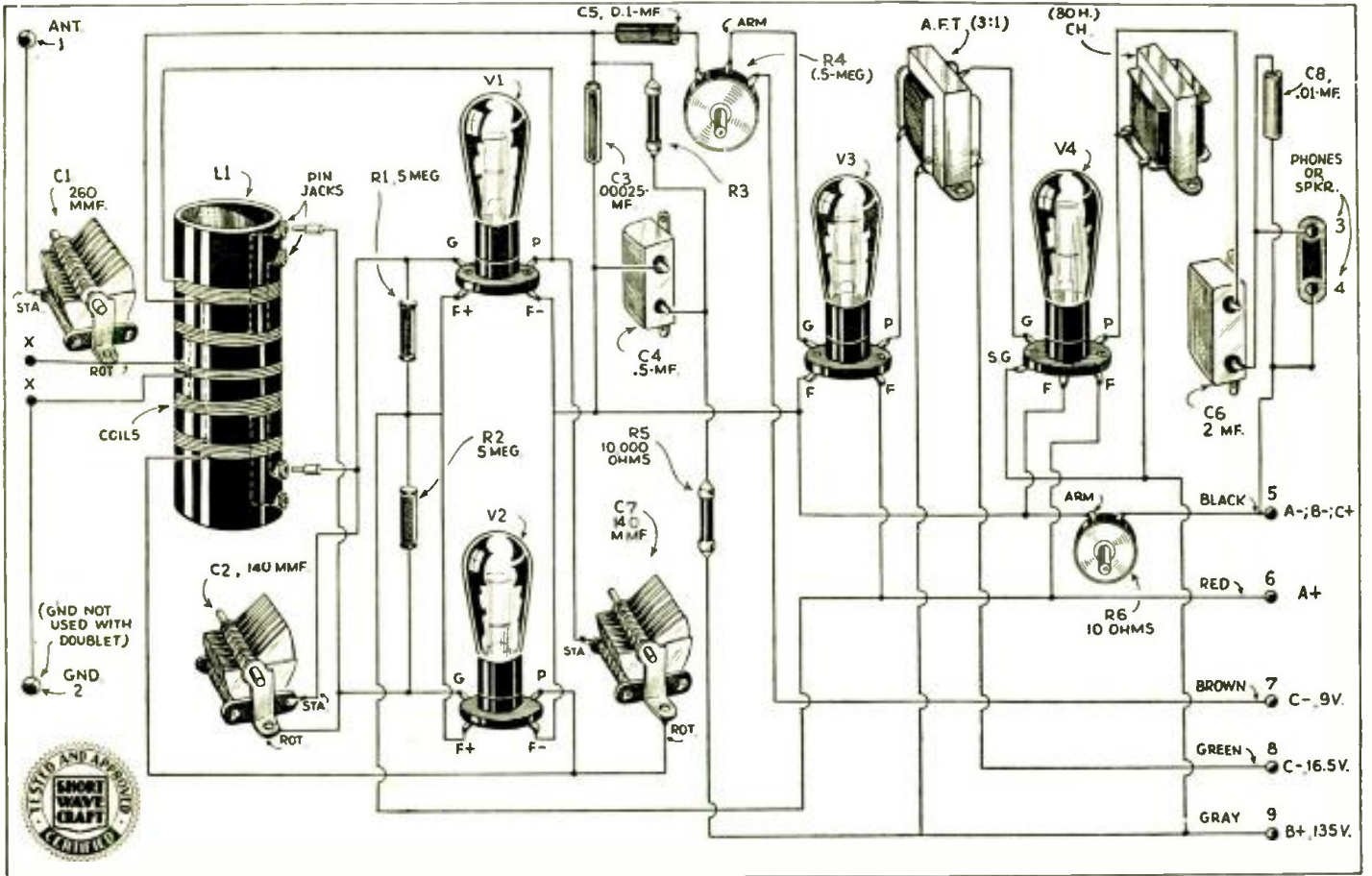

Picture wiring diagram for the Denton new "Stand-By" Receiver is presented above and practically anyone can follow this diagram. If they desire to construct this very efficient and smooth-working receiver, all of the connections are made extremely clear.

ter of the coil form (1 1/8 inches) and proceed to wind the various sections of the coils starting from the center and working first to the right and then to the left. Remember that there must be an absolutely equal number of turns in both halves of the windings. For example, the feed-back coil has one turn each side of the grid coil and that the grid coil is split into two windings each side of the antenna coil. Remember to watch when connecting the outer ends of the plate feed-back coil to the plate terminals of the tubes, that the plate winding of the upper tube (in the circuit diagram) is wound next to the grid winding of the lower tube. This is very important and the connections at this point should be checked over very carefully, otherwise the detector circuit will not oscillate.

(Continued on page 754)

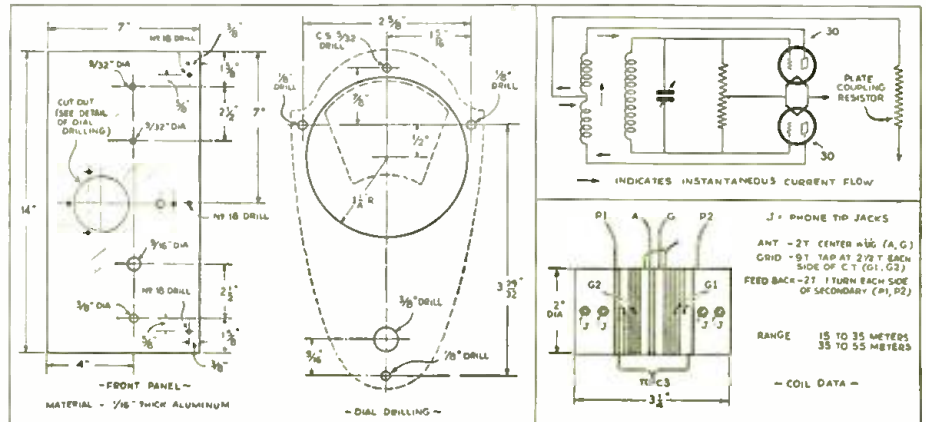

In the drawing above we find details for laying out the front panel, drilling holes for National dial, as well as schematic of action in push-pull detector circuit, and details for the two-band coil.

STATIC ALARM

By **ARNOLD
DOUGLAS FINLEY**

You will be highly intrigued by the experience of Jerry Brent and how he combined radio and electric signs to round up a gang of yeggs.



"As he reached his third 'maybe' he noted also that in the center of the top line there was something that was flashing . . . COM . . . COM . . . COM . . . COM . . ."

● THE building of the Hub National Bank lifted its eighteen stories over the roofs of what was fast ceasing to be a residential district. In fact the bank was the vanguard of the encroaching business area. As if to remind the remaining residents of the neighborhood of their imminent eviction a huge neon sign broadcasted on beams of light the superiority of HOMESPUN HOSIERY from a steel structure on the roof.

In the eyes of Advertising Specialties, Inc., who built and maintained it, the sign was a thing of beauty. The nearby inhabitants held other opinions, however. The slightest current leakage in the sign resulted in a deafening series of crashes in speakers devoutly dedicated to Amos 'n Andy. Slightly lower murmurings of discontent issued from the sancta of the four nearby amateurs. Every type of filter had been tried and found useless. The broadcasts of the sign were all-wave, all-frequency, and all too frequent. The sole ray of hope in the situation lay in the fact that the interference usually denoted a broken unit in the sign which lowered its advertising value enough to warrant speedy repair by Advertising Specialties, Inc.

As a result of this situation the neighborhood had adopted the practice of serving as a sort of night-watchman for the company, informing them more or less beligerently when their display needed attention.

In answer to one such summons about nine o'clock on a February evening Jerry Brent, electrician for Advertising

Specialties, stepped inside the back door of the Bank Building and laboriously plodded up the eighteen flights of stairs which, during the day, served as merely a fire exit, but which in the evening formed the only way to the roof.

This time the trouble consisted of a dead neon unit. Jerry jumped its terminals with a piece of wire and removed it, starting the sign anew. Except for the defective "M" in his hand everything was satisfactory and the surrounding world was cautioned once more to accept no substitutes for HO ESPUN HOSIERY. The absent letter merely added interest to the sign and peace once more hovered over many a neighboring radio speaker, while ICWN, a block away, revived his hope of keeping his sked with Ireland. Jerry glanced at the time-switch. It was ten thirty-five. He crossed to the penthouse and began the long descent to the ground. As he walked along the landing of the sixth floor he looked down the airshaft. Through the windows which pierced the stairway at each floor a dim moonlight filtered in, its silvery beams giving a rather ghastly appearance to the long succession of stairs.

That which caused Jerry to stop suddenly and attempt to peer through the semi-darkness was not, however, the silvery beams of light but the fact that not all of the light was silvery. Way down on the second floor there was a suggestion of light too, but it was a decidedly yellow beam of which no

moon, even in so unromantic a spot as the Hub Building, would be guilty. As he descended once more Jerry recalled the layout of the building in his mind. The Hub National occupied the first floor while the subsidiary Corporation had the second. These two floors had no exit to the emergency stairway, being served in this capacity by an ingenious burglar-proof exit. There was, then, no explanation for the yellow light. As Jerry approached the second floor, however, he saw that this was not strictly true. The yellow beam was explainable. In the wall dividing the fire exit from the Hub Corporation was a large, roughly cut hole, made by removing the bricks and then cutting away the interior metal partition. Just inside this freshly made entrance was an electric lantern. Jerry dropped flat on the stair and found that he could view the scene within in comparative safety. The low hiss of escaping air which he had noticed turned out to be an acetylene torch. A shadowy form was bent over it trying to adjust the flame. Another was laboriously tearing up the composition flooring while a third man was seated inside the opening apparently serving as a sort of sentry.

Jerry considered. They were working on the section of floor just over the main vault of the bank. To pierce the floor itself would be easy but the thick steel plates of the roof of the vault would take possibly hours to break through. There was ample time to give an alarm but apparently no means of doing so. Passing the sentry and reaching the ground was out of the question. Above him all the doors were locked except that opening on the roof and the latter was a sheer eighty feet higher than any adjacent building.

Jerry retreated to a point of safety on the sixth floor and struggled for an idea. The obvious one came: the portable fifty-six meg rig. But that was home on the shelf and served as nothing but an object of longing.

"This is the time that the ham does not come through," he thought hopelessly and, seeking a place where he might move without fear of being discovered he mounted again to the roof.

Emerging from the penthouse he leaned back against the parapet and looked out over the city. The neon sign was almost above him, its flashing action spelling out first FOR STYLE, then FOR COMFORT, next FOR ECONOMY, and finally in huge ten-

(Continued on page 767)

UNITROL Receiver

Simplifies Band-Spread Tuning

By GEORGE W. SHUART, W2AMN

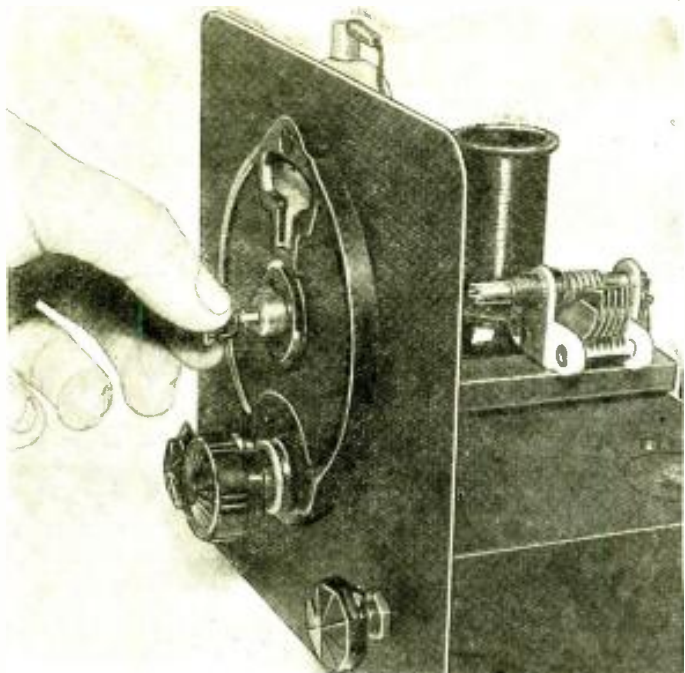

In order to change the tuning to "band spread," one has simply to operate the special button at the center of the dial.



● THE main feature of this receiver is the tuning condenser, which incorporates, so far as the writer is aware, something a little different from the usual *band-spread* arrangement.

Most everyone operating a short-wave receiver will admit that the usual *band-spreading* methods on the average receiver are rather awkward when it comes to covering any large range of frequencies. That is, it is impossible to cover the entire range of a given short wave plug-in coil with a single dial and still be able to have *band-spread* when it is desired. Most receivers have two separate controls namely, the tank tuning condenser and a small one used for spreading out the congested short-wave

amateur and broadcast bands. In this method, unless both condensers have accurately calibrated dials, it is impossible to reset them for a given frequency and have the same ratio of capacity between the two as before.

Then again in tuning across the whole range of a plug-in coil, it is necessary to tune a short way with the small tuning condenser and then reset the tank condenser, and if you should overshoot the mark with the tank condenser, you will miss out on a large portion of the band you wish to cover.

A brief description of the receiver may be in order, before we continue with the description of the condenser. A type 32 screen grid tube is used as a regenerative detector which in turn is impedance-coupled to the type 33

pentode audio stage. The coupler is a regular audio transformer with its primary and secondary connected in series to form a high impedance plate load for the detector tube. Resistance coupling could be used but with a slight decrease in audio volume. There is only one draw-back with impedance coupling and that is that there is usually a very serious fringe howl when the detector is brought into an oscillating condition. However, this is easily overcome by shunting a 250,000 ohm resistor across the transformer, which is now a choke.

Regeneration Control

Regeneration is controlled by varying the screen-grid voltage of the detector (Continued on page 747)

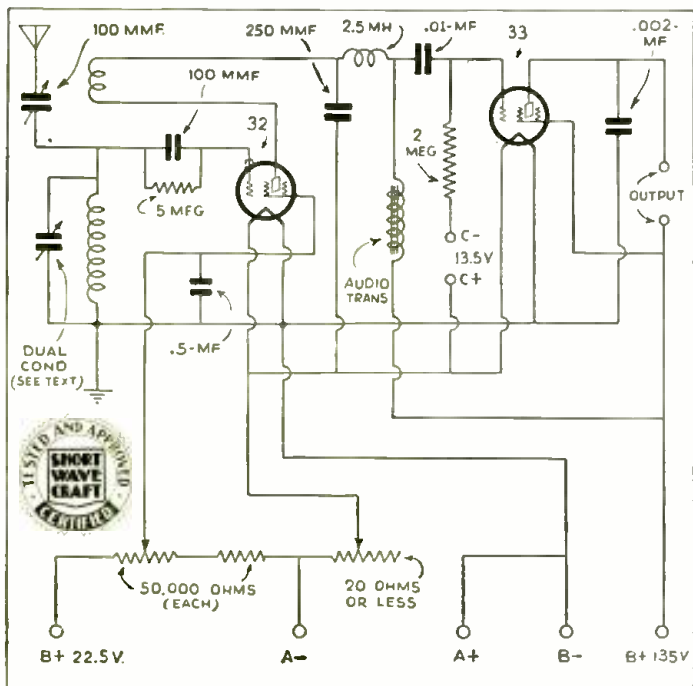

Here is the simple hook-up for the "Unitrol" receiver, which gives optional "band-spread" tuning.

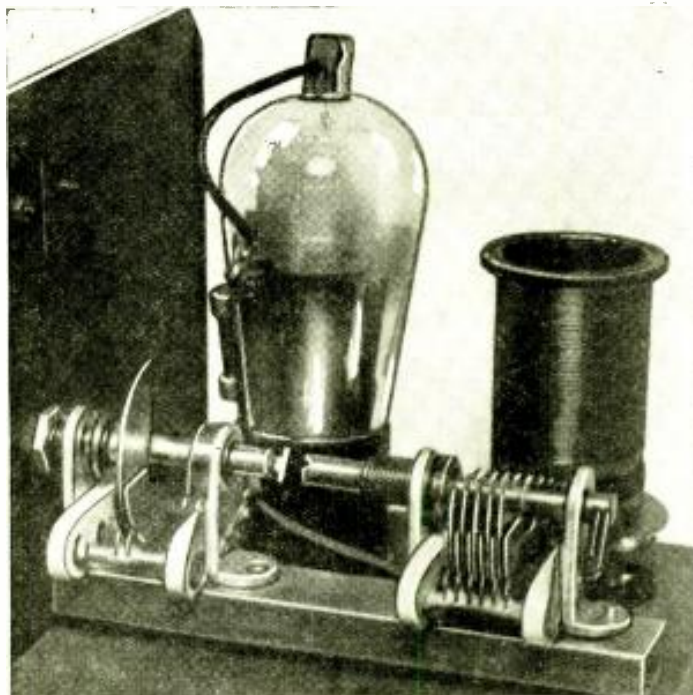

A close-up of the rear, showing "tank" and "hand-spread" tuning condensers, together with clutch.

WORLD-WIDE SHORT-

An Unusual Screen-Grid Circuit

● IN a recent issue of *The Wireless Engineer and Experimental Wireless*, an interesting circuit was shown, in which a single screen-grid tube was employed both as a detector and as an A.F. amplifier. This circuit, shown here, is of particular interest to the short-wave experimenter, as it is desirable in most S.W. sets to limit the number of tubes, in order to keep the tube noises at a minimum. However, it is also desirable to obtain the greatest possible amplification, and this kink is one way to conserve tubes without loss in sensitivity.

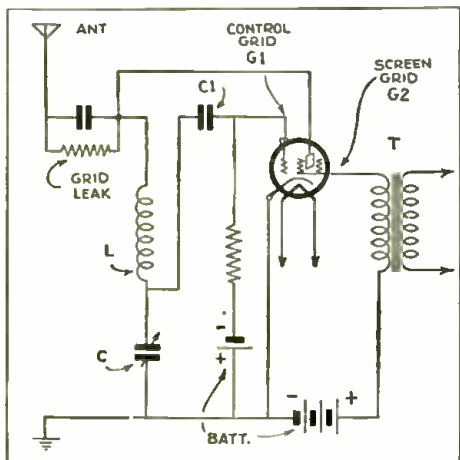

In the circuit shown above, a single screen-grid tube is employed both as a detector and A.F. amplifier.

The explanation accompanying the circuit reads as follows: "A screen-grid tube of normal type is used as a combined diode rectifier and A.F. amplifier. The modulated signal is applied across the plate P and cathode C through a grid-leak combination GL. Rectified currents are fed from the junction of a coil L and condenser C (forming a radio frequency shunt) through a condenser C1 to the control-grid G1, the usual screen-grid G2 being coupled to the next stage through an A.F. transformer T. If a pentode tube is connected up in a similar manner, the extra electrode can be used as a space-charge grid."

Wave-Change Switch

● *Funk-Technische Monatshefte*, published in Berlin, Germany, recently contained a novel circuit for shifting from one short-

● The editors have endeavored to review the more important foreign magazines covering short-wave developments, for the benefit of the thousands of readers of this magazine who do not have the opportunity of seeing these magazines first-hand. The circuits shown are for the most part self-explanatory to the radio student, and wherever possible the constants or values of various condensers, coils, etc., are given. Please do not write to us asking for further data, picture-diagrams or lists of parts for these foreign circuits, as we do not have any further specific information other than that given. If the reader will remember that wherever a tuned circuit is shown, for instance, he may use any short wave coil and the appropriate corresponding tuning condenser, data for which are given dozens of times in each issue of this magazine, he will have no difficulty in reconstructing these foreign circuits to try them out.

wave band to another, and incidentally the entire circuit is of interest to American short-wave "fans", who are naturally curious to know what the experimenters abroad are doing.

As shown in the illustration, a switch S throws a coil across either part of the regular tuning coil, or the entire coil, and as two coils in parallel have less inductance than either coil, the frequency to which the tuned circuit will respond is increased. A third position of the switch disconnects the shunt coil from the circuit.

The remainder of the diagram shows a screen-grid tube as the detector, using parallel feed of the tickler coil, feeding into a power pentode, using the resistance-capacity method of coupling. Power is furnished by a conventional power unit with a full-wave rectifier. It is claimed that loudspeaker results are obtained from this "two-tube" receiver.

Transatlantic S.W. Converter

● IN *Le Radio* some time ago was described a short-wave converter that had been used with much success in receiving programs from the United States.

The article is reproduced in part below: The construction is not difficult. Besides the tube, the following material is required: 2 variable condensers, .0002 mf.; 1 .0005

mf. variable condenser which tunes the coil L3 circuit to the intermediate frequency; 1 fixed condenser, C4, .0002 mf.; several feet of copper wire for tuning coils (No. 20 D.C.C. wire); a few binding posts; a rheostat and a tube socket.

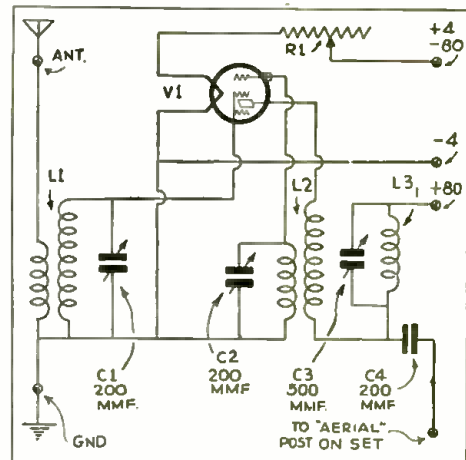

European short-wave listeners have had considerable success in picking up programs from the United States, by means of the short-wave converter shown in the diagram above.

The main difficulty, and this is a small one, is the winding of the coils. Coil L3 has 55 turns which are closely wound on a form 3 5/32 inches in diameter. The natural wavelength of this coil is about 400 meters. The other coils can be wound on tube bases. However, it is not advisable to introduce the molded material of which the bases are made into the high frequency field. Therefore, these coils are made differently: a form 1 5/16 inches in diameter is used to which the end of the wire is attached. A single turn is wound and under it, three evenly spaced thin cardboard strips, 2x 3/4-in. are inserted. Ends 2 inches long are left at the top and the bottom of each coil. When the required number of turns are wound, a few drops of sealing wax are poured over the cardboard strips and the ends of these strips are bent over the wire before the wax begins to harden. In this way the turns of the coil are permanently held together in three spots. The coil is then removed from the form and mounted by the wires to the prongs of the tube-base that acts as a support and also facilitates coil changing.

The coils for transatlantic reception are made as follows, although many other sizes can also be constructed:

ANTENNA COIL

Grid	Aerial
5	3
10	7

OSCILLATOR COIL

Grid	Plate
5	10
10	15

The values of the parts used in this simple one-tube converter are shown in the circuit diagram.

In operation, the coil L3 is tuned to about 450 meters and the broadcast receiver to which it is attached is tuned to resonance. The short-wave converter is then connected to the aerial binding post of the receiver and the aerial and ground attached to the converter. Then all that is necessary is patience in tuning.

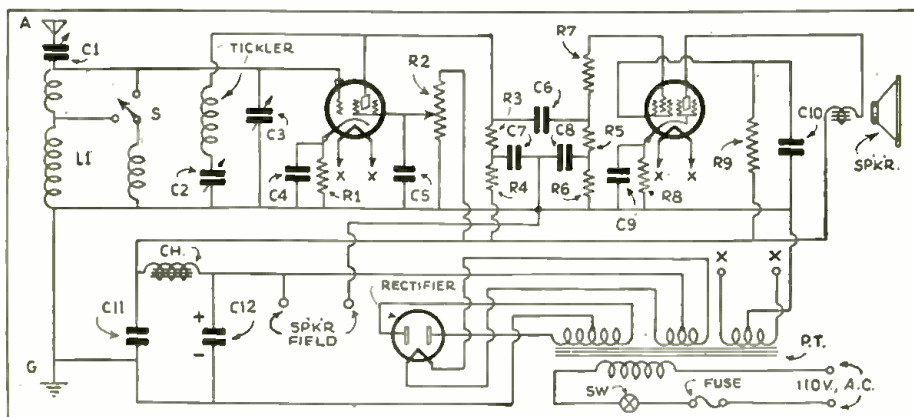

One of the latest European short-wave receiver circuits, which enables the operator to tune in different bands by simply throwing a switch, S. Loud-speaker results are claimed for this 2-tuber.

WAVE REVIEW • Edited by C. W. PALMER

Iron Core Coils for Short Waves

• WE have mentioned several times in past issues of this department about the *iron core* coils that are receiving unusual attention in the European magazines. Up to this time, though, these coils have been limited to operation on what the English magazines call the intermediate and long waves (corresponding to our broadcast band and long waves).

Now, however, a coil has been introduced which is designed to cover the wavelengths between 13.8 and 78 meters, in two sections. This coil was described in a recent issue of *Amateur Wireless* and was recommended very highly.

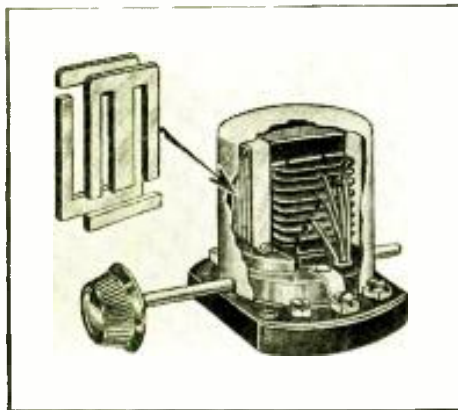

The latest idea in short-wave tuning inductances is undoubtedly that of employing special iron cores—the picture above shows a new European S.W. type.

It is claimed that the resistance is lower than ordinary air coils, giving better selectivity and sensitivity, and in addition, the field is localized by the closed core so that shielding in multi-tube sets is not very important, at least so far as the coils are concerned.

In the accompanying illustration is shown one of the coils with the shield cut away to show the interior. The shape of the special iron laminations is also shown. The knob is a switch that changes from the lower band to the upper one, so that complete coverage of the frequencies for which the coil was designed, can be obtained.

A Simple Transmitter for Very Short Waves

• THE simple but effective circuit shown in the accompanying illustration appeared in the French review, *Le Haut Parleur*. It has a constant output and can be operated on very high frequencies—by the use of harmonics of the actual oscillation frequency.

The circuit shows an electron-coupled oscillator using a screen-grid tube. This oscillator is of the same type as used in some superheterodyne sets as local frequency generator.

The oscillatory circuit L1, C1, together with the three first elements of the tube (cathode, control-grid and screen-grid acting here as a plate) form an oscillator of the Hartley type. The coupling between the grid and plate oscillatory circuits is simultaneously electrostatic and electromagnetic. The bypass condenser C4 (.001 mf.), puts the screen-grid at the same potential as the chassis. An outside shield electrically connected to the chassis prevents the coupling between the oscillator and the plate circuit. There is an electronic coupling between the latter and the oscillator, a fact that is due to the action of the electrons which are emitted from the cathode. Either the same frequencies as generated by the oscillator or its harmonics can be picked up by the tuned circuit L2, C2.

The circuit shows an indirectly heated screen-grid tube of the type generally used in receiving sets and with a "B" voltage of 250 V. The dimensions of the parts are

the following: R1, 1,000 ohms; R2, 40,000 ohms; R3, 60,000 ohms; R4, 5,000 ohms, or an efficient choke; C1 and C2 depend on the frequency; C3, .002 mf.; C4, .004 mf.; C5, .002 mf.

For frequencies in the range of the 10 meter band, the coil L1 consists of 10 turns 3/8-in. in diameter made of bare copper wire. The cathode lead is connected to the sixth turn from the grounded end.

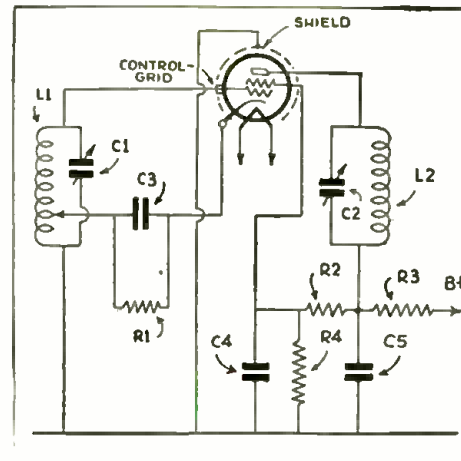

An electron-coupled oscillator with constant output and which can be operated at very high frequencies, as explained in the text.

The circuit of L2 and C2 should be adjusted to resonance with L1, C1 if the output is to be the same as the oscillator frequency. In this case, the coils and condensers should be identical. If twice the frequency is desired, it is only necessary to reduce the size of L2 and adjust L2, C2 to twice the frequency of L1, C1. The greatest efficiency, of course, is obtained when the output circuit is tuned to resonance with the oscillator frequency.

A German Short-Wave Set

• THE circuit shown here is novel for several reasons. In the first place, it is of German origin, although it appeared in a magazine published in Sydney, Australia—*Wireless Weekly*.

The set is a regenerative type of unit, in which the oscillation is controlled by a .00025 mf. condenser connected in series with a fixed capacity of .005 mf. This is done to make the adjustment of oscillation less critical; and in practice, in experiments conducted by the writer on an existing S.W. receiver, materially smoother control resulted.

Next, two .0001 mf. variable condensers are connected together in series as the tuning control. This produces a sort of continuous *band-spread* effect which further simplifies the task of tuning.

Third, two methods of coupling the aerial to the grid circuit of the detector are shown. One is the conventional series condenser method, while the other consists of a network of resistors, in addition to the usual condenser. The latter method of connection was rather puzzling to the writer at first glance, and as no explanation was offered for its use, it was decided to try it out.

The result was surprising. While the signal strength from a distant station was cut down somewhat when this connection was employed, the signal-to-noise ratio was

much improved, and the degree of fading was also cut down. It is not known if this was the intention of the designer of the set, and the action is not thoroughly understood, but you fellows on the look-out for new and interesting kinks in short waves might give it a try!

The remainder of the set consists of a

conventional transformer coupled audio amplifier, followed by a pentode output tube, resistance-capacity coupled to the first A.F. amplifier. The entire design of the receiver shows consideration to ease in operation which should be an attraction to the short-wave beginner. The values of all parts are shown. Standard coils may be used.

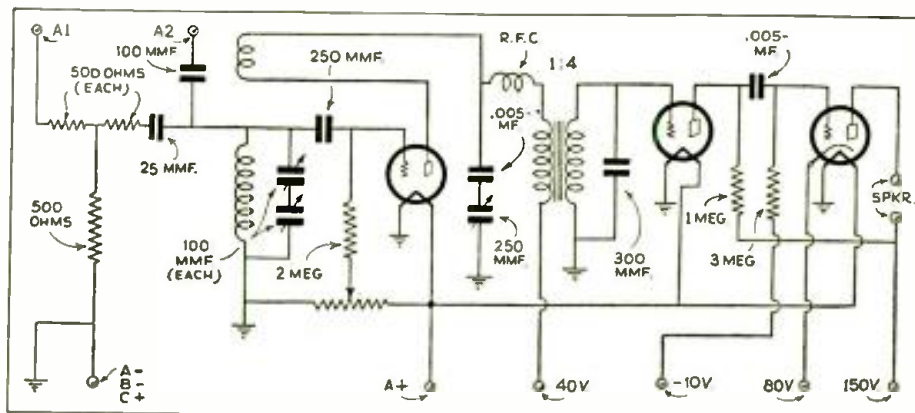

In this receiver hook-up, it will be seen that the regeneration is controlled by two condensers connected in series, which renders the oscillation adjustment smoother than usual. Note the method of obtaining "band-spread" tuning by using two condensers in series.

SHORT WAVES and

WSFTB — A 12-Year Old Marconi

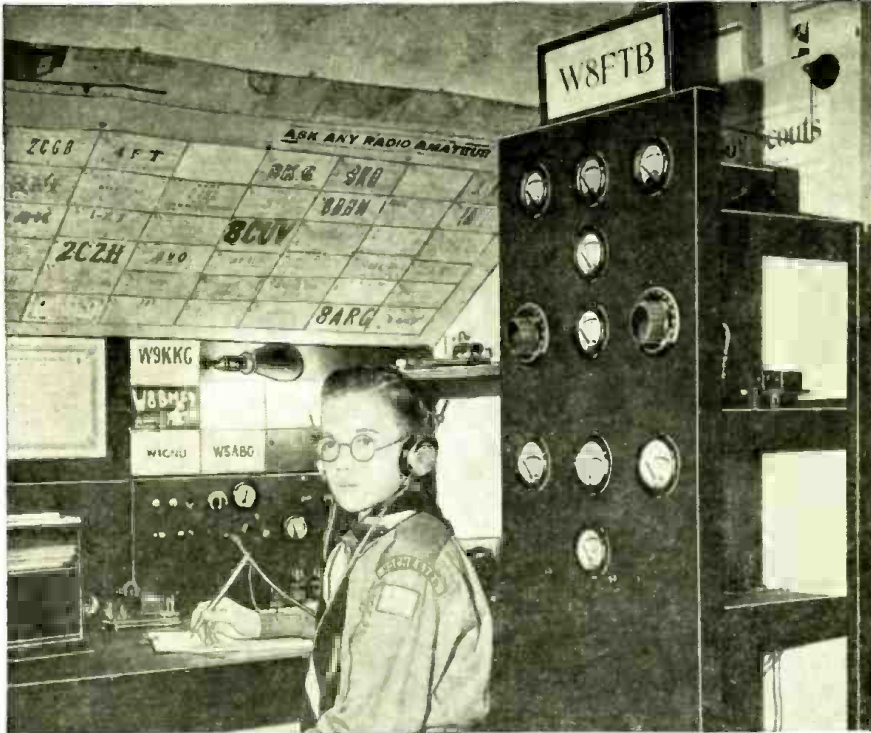

The remarkably fine licensed amateur station owned and operated by Henry L. Carter, Jr., WSFTB.

Editor, SHORT WAVE CRAFT:

I thought you might be interested in a photo of my radio station and a short description of my radio activities at WSFTB, located at 45 Sheldon Terrace, Rochester, N. Y.

My radio activities date back to November, 1931, when I first became interested in the short-wave radio game; my license was issued January 14, 1932—at that time I was 10 years old. With the assistance of my father (he was on the air back in 1923—ex8BOW) I built my transmitter, crystal control—47 Xtal. oscillator, 47 buf-

fer, 210 final amplifier. I operate on 3530 and 3840 kc. 80 meter band.

I have worked stations all over the United States, Canada and Mexico. I am the youngest member of Scout Amateur Radio Net, and holder of Army Amateur Radio Station appointment, also Official Relay Station. I can copy 20 per, and send "plenty fast."

I am interested in exchanging photos of amateur stations; anyone interested write me and I will send your photo, also all members of SHORT WAVE LEAGUE.

Many thanks to publisher of SHORT

WAVE CRAFT and their interest in cooperation with the Amateur and Short Wave Listener.

A few compliments about your publication—my first issue was the December, and I really think I read every word in that issue—and I also sent in my application for membership in the SHORT WAVE LEAGUE. My certificate is framed and hung on the wall with my line up of "Degrees of Merit." I really enjoy reading your magazine and think it is 100 per cent short-wave and should be in every "Ham Shack." I have been so busy with my "Radio" and "Scout" work I have failed to acknowledge receipt of my certificate, also my personal opinion of SHORT WAVE CRAFT. My Troop has organized a Radio Club—we have 16 members, and I would like to have them become members of the SHORT WAVE LEAGUE. SHORT WAVE CRAFT would be a fine magazine for these boys to read, for the advancement of short waves.

I am writing now for two magazines each month—not for money but only to help the advancement of amateurs and short-wave radio.

I am only 12 years old—I have been in the amateur radio game since I was 10. I am the youngest holder of Official Army Amateur Radio Station designation, also Official Relay station in the country. My station is valued at about \$1,500.00.

Henry L. Carter, Jr., WSFTB
Member SHORT WAVE LEAGUE
45 Sheldon Terrace
Rochester, N. Y.

(Shades of Heinrich Hertz—we'll bet he would be envious indeed of this "superfine" station, which includes transmitter and the "whole works." To think, readers, that this young gentleman is only 12 years old! At the rate he is going he ought to be a Brigadier General in the Army, or an Admiral in the Navy by the time he is 21. This is, without a doubt, one of the finest stations the editors have ever seen, taking into consideration the arrangement, the apparatus employed and the age of the operator. Also, don't lose sight of the fact that Master Carter has the distinction and honor of being designated as the youngest holder of an assignment from his Uncle Sam, as an Official Army Amateur Radio Station; also, Official Relay Station.—Editor.)

Wow! What a Station!



Holy Mackerel! What a layout this baby's got! The lucky "op" is R. R. Kubler, of Asheville, N. C.

Editor, SHORT WAVE CRAFT:

Here's photo of amateur radio station W4GW, and also description of the station, which is as follows: W4GW is located in Asheville, N. C., which lies in the western part of North Carolina in the mountains. W4GW is a unit station of the Naval Reserve.

The high rack on the left-hand side of the picture is the phone transmitter, operating on 3,909 kc. using a 210 osc.—two 210 as buffers and a 211 final amplifier, modulated by a 212D, with 2,000 volts on the plate, supplied from a motor-generator set located in the basement. A double microphone is used, with two stages of amplification. The two center panels are the transmitter used for naval reserve drills and consists of a 47 oscillator, 210 buffer, 852 buffer and an 849 final stage, which has an input of 800 to 1000 watts. The last panel is an 852 osc. and a 201A amplifier in a M.O.P.A. circuit, with 2,000 volts on both plates of both tubes. The receiver is an FBXA National single-signal set. Much DX has been worked on phone and CW, as W4GW has been on the air for the past 12 years. The licenses on the wall are an Amateur first-class, Unlimited Phone and an old commercial (cancelled) and a new radio telegraph second class and

LONG WAVES . . . OUR READERS' FORUM

radio telephone, first-class. In the lower right-hand side is a Naval Reserve certificate.

R. R. Kubler,
59 Spruce St.
Asheville, N. C.

(Wow! What a short-wave station this turned out to be! We note that you have rounded out the high-power transmitting equipment with a real go-getter short wave receiver—the FBXA National single signal. Our heartiest congratulations to you, Ralph, for your perseverance and skill in building such a fine station and also for keeping this station on the air for 12 years. "Flats off" to W4GW and we hope that many other owners of high power amateur stations, such as this, will "kick in" with photos and description and don't forget a picture, even though it is only a snapshot of the old maestro—you know who we mean, the "man behind the gun."—Editor.)

A FIRST CLASS RECEIVING STATION

Editor, SHORT WAVE CRAFT:

Herewith a picture of my short-wave receiving station. I have read SHORT WAVE CRAFT for the last four years and enjoy reading it very much. Sure can get lots of information out of SHORT WAVE CRAFT.

I use the G.E. K-80 new all-wave set, which works better than any other all-wave set I have tried so far. I designed this receiving station for receiving messages from amateurs, when we have severe storms and all the wires are down. The sign I have on top of the panel with the letters WERS stands for Warrens-Emergency-Receiving-Station.

On the panel I have two sockets, one to the left and another socket back of the set. One socket back of the set supplies 110 volts to the set; other socket supplies Aerial and Ground. The socket you see in the picture supplies 110 volts for testing or repair work. The other side of socket where you see the white wire entering goes from the voice coil of the speaker to the right-hand meter on the panel, which indicates the out-put strength of signal on the set.

The black knob under this is a resistance control on the out-put meter; if the signal is too strong I turn the knob all the way to the right. Turning the knob all the

How Arthur Ozsvath Relayed "Rescue" Message



Arthur Ozsvath (with earphones) and Bob Kapp, both 19, at radio with which they caught distress signals of plane party lost in Hudson Bay region and thus effected rescue.

● THE short-wave "honors," this month, go to Arthur Ozsvath, of White Plains, New York, licensed short-wave station call W2CSM, who picked up an important short-wave message being flashed from a "rescue plane" in Canada. He wound up by following the request radioed from the rescue plane to telephone the message back to Montreal. How our young "radio hero,"

Arthur Ozsvath, handled the message is described in his own way below:

I usually get up in the morning, tune up the transmitter, and go on the air for a few hours. Of course, I did this Monday morning, January 15th. The air was pretty quiet, so I called a CQ. The first station I heard calling me was VE2IC. He was

(Continued on page 746)



Warren Charles of Hagerstown, Md., and his neat S-W receiving station.

way to the left reduces the resistance on the 0 to 3 scale Weston milliammeter.

To the left is a 0 to 150 scale voltmeter to give the exact voltage on the line current; next to the meter is the main control switch. This switch cuts out the entire station, with the exception of the clock.

Underneath the meter is a plate with a red bulls-eye in it, which shows that the current is on.

Above the panel is a world map and on the shelf a certificate of the SHORT WAVE LEAGUE of New York. On the window sill there are two sockets; the left-hand socket is a connection to my Lynch "inverted" L doublet aerial. The socket to the right supplies local broadcast, which uses a Lynch transformer coupled lead-in with shielded lead wire.

I send a Short Wave Listeners Card to all of the Amateurs I hear. At the moment illustrated I am listening to Daventry, England, which is coming in with a very strong signal.

Warren Charles,
727 S. Potomac St.
Hagerstown, Md.

(Certainly a very fine receiving station, Warren, and the way you have the receiver, clock and map, etc., arranged seems to be a very good one. We wouldn't mind having a nice quiet little corner like this one ourselves.—Editor.)

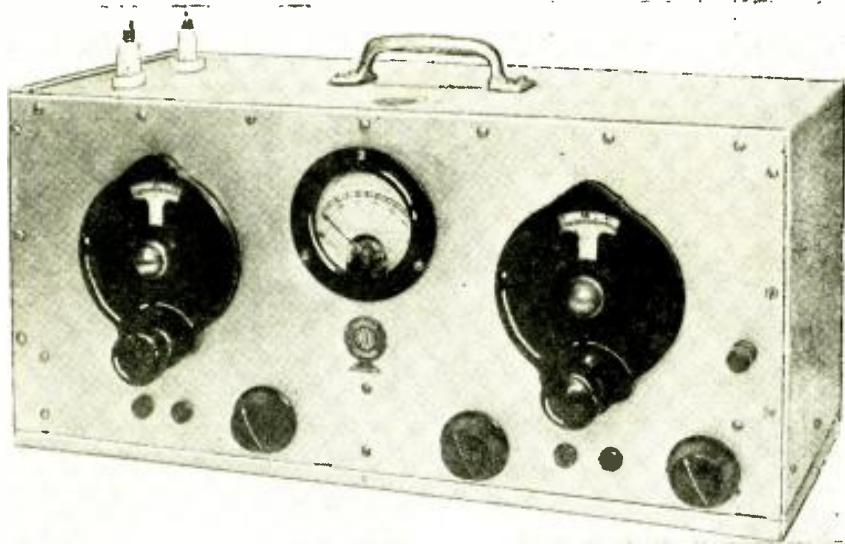

Front view of the 5-meter portable Transmitter-Receiver.

● Mr. Potter, operator of licensed amateur short-wave station, W9FQU, describes a very excellent 5-meter "transmitter-receiver" of the portable type. The receiver operates on the super-regenerative principle and it is provided with two stages of audio frequency amplification. This set is not a transceiver, but has a distinct circuit for both transmitter and receiver. The transmitter employs two 31 tubes in a push-pull oscillator circuit. Class B modulation is employed, the driver tube being a 49, which drives two class B 49 modulator tubes. Batteries supply the plate and filament current.

5 Meter Transmitter-Receiver

By **MARCUS L. POTTER, W9FQU**

\$20.00 JANUARY PRIZE-WINNER

● BECAUSE W9FQU is primarily a phone station, it was only natural to design and build a five-meter transmitter and receiver very shortly after activity started on the 56 megacycle band.

At first no definite design was determined upon, simply because we first wanted to determine whether the transmitter and receiver should be strictly "portable" or otherwise.

After considerable experimental work using both low power receiving tubes with 180 volts of B battery and low-power transmitting tubes, with 500 volts rectified AC on the plates, it was found that the results using 31 type tubes were practically as good as the larger tubes, which used about two and one-half times the plate voltage. It was therefore decided that the trans-

mitter would use two type 31 (two volt filament in series, with a total current drain of 130 milliamperes) in a conventional push-pull circuit, power to be furnished by six volts of "A" battery and 180 volts of "B" battery regardless of whether it be used for portable or permanent station work.

Receiver Design

Receiver design came next, and it was decided to use a super-regenerative circuit with two stages of audio amplification. It is true that more audio power could be obtained by feeding a type 33 pentode directly from the de-

tor and this would eliminate one tube; however, the current drain on the B battery would be several milliamperes more. For use in portable work it is always, of course, very desirable to utilize the smallest B current drain consistent with good results, and for this reason a two-stage audio unit was used instead of a power pentode.

The next consideration was whether it was desirable or not to incorporate both receiver and transmitter in one case. Because portability was desired, it necessarily follows that it, of course, would be good practice to follow the idea of building both transmitter and receiver in one unit. It should be distinctly understood that the receiver-transmitter is not of the *transceiver* variety. The receiver is entirely separate from the transmitter, it having its own apparatus and tubes. A small amount of weight could have been eliminated by having one set of tubes for both the receiver and transmitter thereby making it a *transceiver*, but the saving effected in this regard would have been very slight and would not offset the advantages gained by using separate tubes for both transmitter and receiver.

Case Rigid Yet Light

With all these ideas in mind, the portable 56 megacycle transmitter-receiver shown in the pictures was designed. The exceptionally rigid case is made of light weight cadmium-plated steel, which will more than stand the abuse usually encountered by portable apparatus. All coils clear the case and sub-panel, which also acts as a shield, by at least 2 inches, which minimizes the amount of r.f. loss that would otherwise be incurred.

Looking at the back of the chassis, the receiving apparatus is on the left-hand side. Thirty type tubes are used

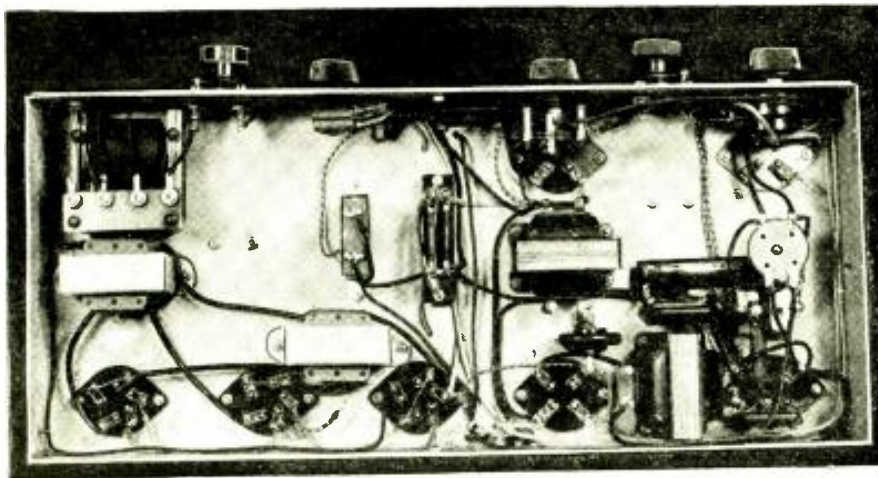

A bottom view of the 56-megacycle Transmitter-Receiver.

for the detector, interruption frequency oscillator and the first stage of audio. The fourth tube—the second audio amplifier—is a 31 type power tube, which supplies more than enough power to operate a loud speaker. Plug-in coils are used in the receiver so that if found desirable at any time the frequency band covered can be either raised or lowered from the present amateur five-meter band.

Transmitter Uses 31 Tubes

Located on the right of the chassis is the transmitter. Two type 31 tubes are used in a push-pull oscillator circuit. Class B modulation is employed, the driver tube being a 49, which drives two Class B 49 modulator tubes. 180 volts of B battery from an external battery box supplies both the Class B tubes and oscillator tubes. One hundred per cent modulation is assured by this combination.

Looking at the illustration showing the front view of the unit the National velvet-vernier dial at the left controls the frequency of the transmitter, the tuning covering the amateur band of 56 to 60 megacycles. The other National velvet-vernier dial at the right tunes the receiver which also covers the 56 to 60 megacycle amateur band. The knob at the lower right of receiver tuning dial controls the antenna tuning condenser; the receiving antenna connection being the binding post on the extreme right. The knob on the lower left of the receiver tuning dial is the receiver off-on switch and volume control. The third knob to the lower right of the transmitter tuning dial is the transmitter off-on switch. The two tip-

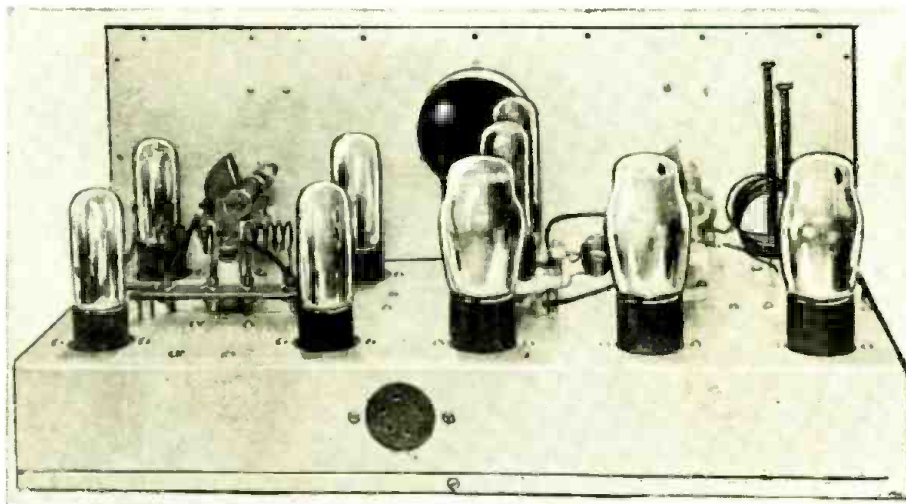

A rear view of the 56-megacycle Transmitter-Receiver.

jacks under the transmitter tuning dial are for the single-button microphone input, and the two tip-jacks under the receiver tuning dial are for the head phones or loud speaker.

Operation of Set

In operation the receiver is left on all the time, thereby permitting a constant check on the quality of transmission. During reception of another station, the transmitter is turned off but this can be done so quickly that it practically amounts to duplex operation. Keeping the transmitter off while receiving also prolongs B battery life, the transmitter draws about 30 milliam-

peres steady current and 60 to 70 milliamperes during modulation peaks and the receiver B battery drain is approximately 15 milliamperes.

Most any type of transmitting antenna may be used. Consistently good results, however, have been obtained with a Zep type, having four-foot feeders and a sixteen foot flat-top. For automobile work a current fed type consisting of two four foot pieces of wire attached to the antenna posts and separated 180 degrees apart have given exceptionally good results—R7 to R8 signals having been reported for distances up to three miles. During opera-

(Continued on page 756)

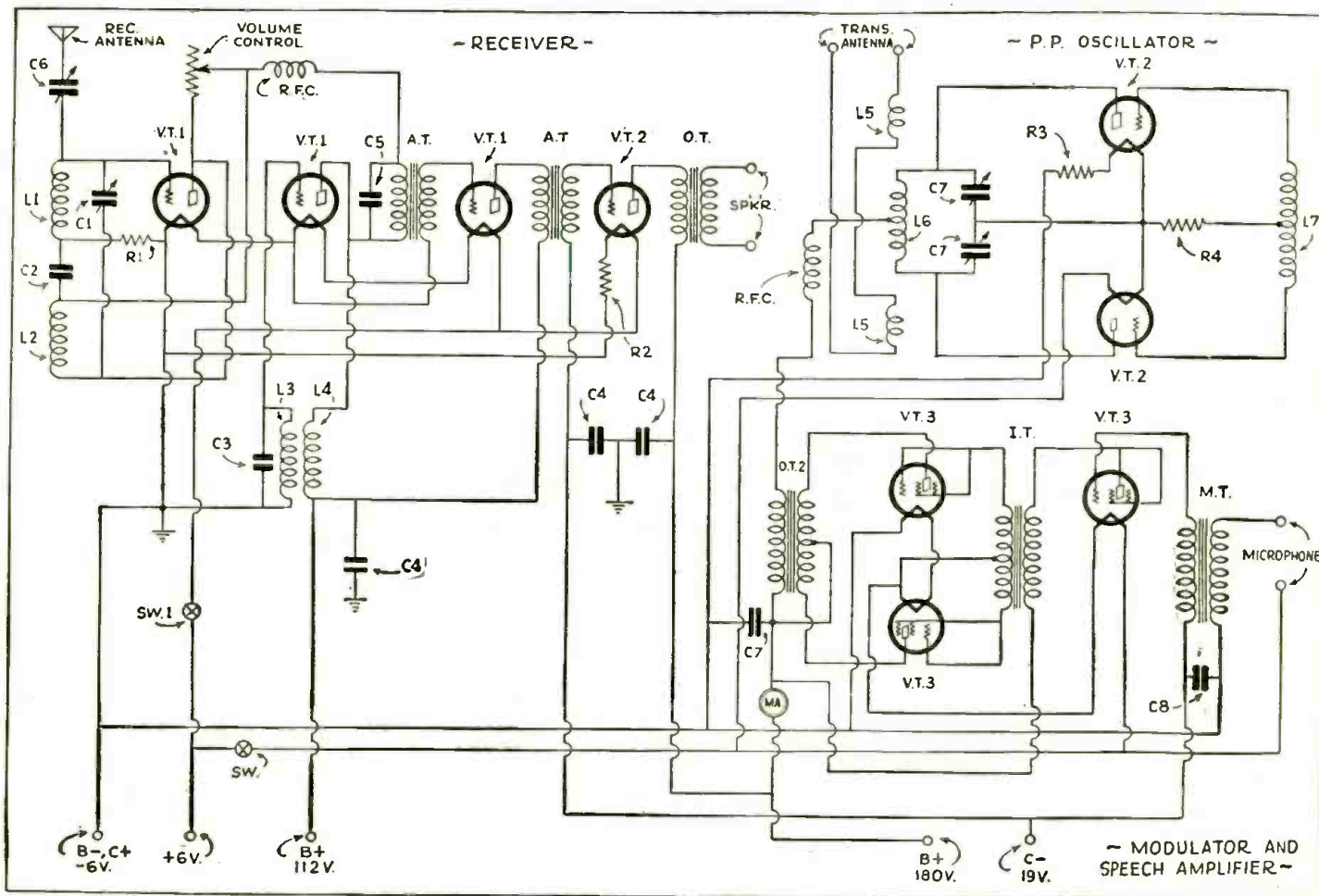
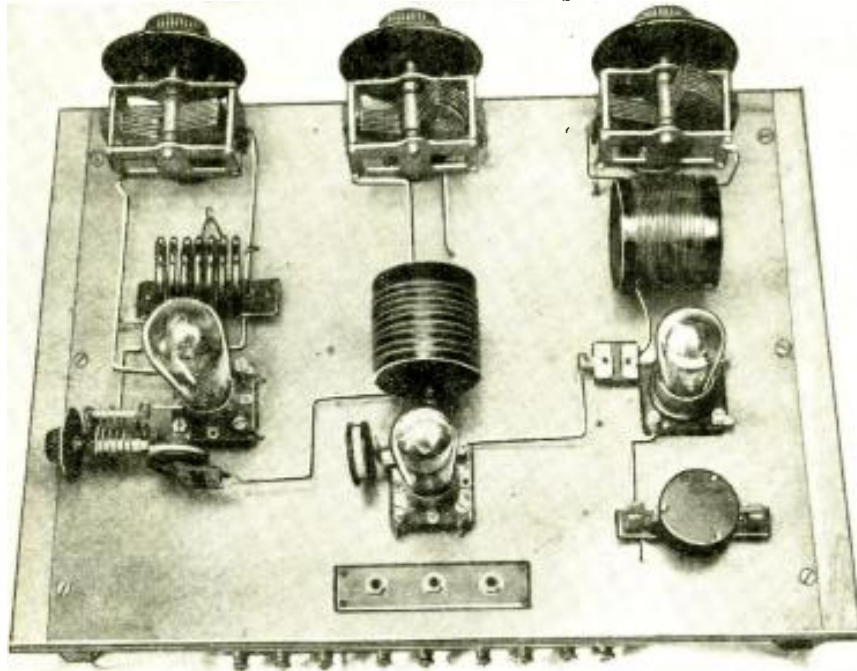

Diagram of the 5-meter Transmitter-Receiver here described by Marcus L. Potter, W9FQU.



Crystal-control has become so common in first-class amateur transmitting stations that no "Ham" can ignore the subject; if he does not employ it at present to stabilize the frequency of his transmitter, he will sooner or later undoubtedly adopt it. The editors are very happy to present this exceptionally informative article by Mr. Stahl, who describes in a clear way how to grind your own crystals—and how to use them.

Left—rear view of the transmitter here described by the author and which has crystal-control to stabilize its frequency. This transmitter uses a '10 tube in the output stage.

CRYSTAL-CONTROL

for the Lean Purse—By BERNHARD STAHL

● FOR a long time, the amateur of ordinary means has looked with envy upon the owner of a crystal-controlled transmitter, but due to the supposed expense, he has continued to push into the ether all sorts of noises, mistaken, at times, for radio signals. After having listened to all forms of such hash for the past few years, we have investigated to see just how reasonably one could construct a crystal-controlled rig. When we were through and had counted up our expenditure, we still were at a loss to understand why low-powered apparatus of this type is not used by the owners of present squawkers.

In designing the described line-up, we limited ourselves to a type '10 output stage, as this is the power used by the average amateur, although one may increase the final output by the addition of higher-powered amplifiers. The time and expense involved does not exceed that of the self-excited transmitter and still the emitted signal is all that may be desired by the most critical.

Construction

All of the equipment was mounted upon a bread-board 22x16 inches, which was obtained from the local hardware store and was given two coats of clear Duco. Two pieces of wood, 15 and 1/2 inches long, 3/4 inch thick and two inches wide were screwed to the underside of this board, as shown in the photograph. This permitted most of the wiring to be done below the top, improving the final appearance greatly.

Almost all of the necessary parts required were obtained from an old broadcast receiver of the neutrodyne type, which had been purchased from a local radio store for \$1.50. This was completely disassembled and in taking

stock we found that we were in possession of three variable condensers, three R.F. transformers, having perfectly good bakelite forms, and a number of small fixed capacities, not to mention the panel which was cut up into the various shapes and forms needed for the set.

The three tuning condensers are fastened to small stand-off insulators with one inch brass angles; in order that all connections may remain tight, lock washers are used under each nut in the process of assembly; this idea is adhered to faithfully and had well

be copied by the builder of any piece of equipment.

The R.F. Coils

Next, the R.F. coils are taken apart and re-wound for their new use, given a coat of clear Duco and allowed to dry. When dry, holes are drilled for mounting and the crystal coil put into its place on the base-board. Two pieces of the bakelite are cut from the old panel and drilled as shown in Fig. 1, and are used as mountings for the buffer and amplifier coils.

The three sockets used in the trans-

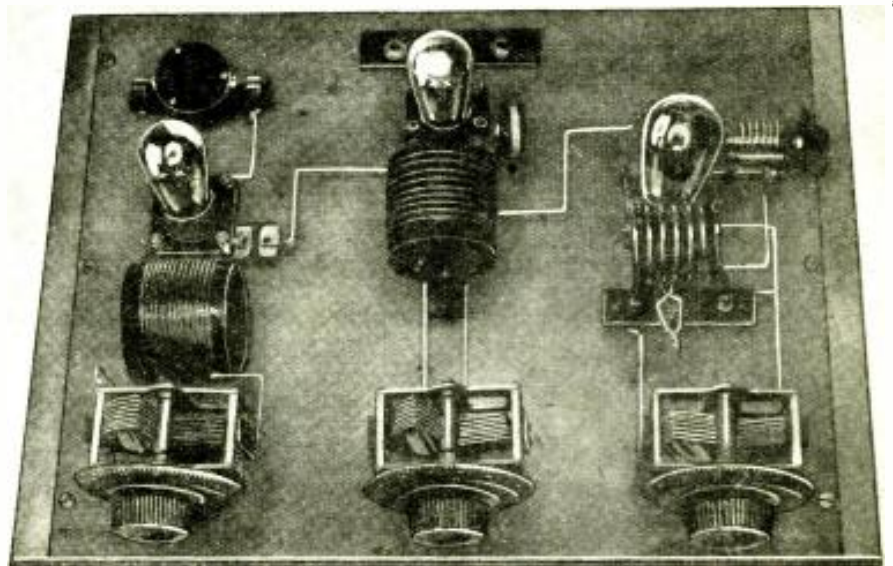

Front view of Mr. Stahl's transmitter which is fitted with crystal-control, the details for grinding the crystal being given in the accompanying article.

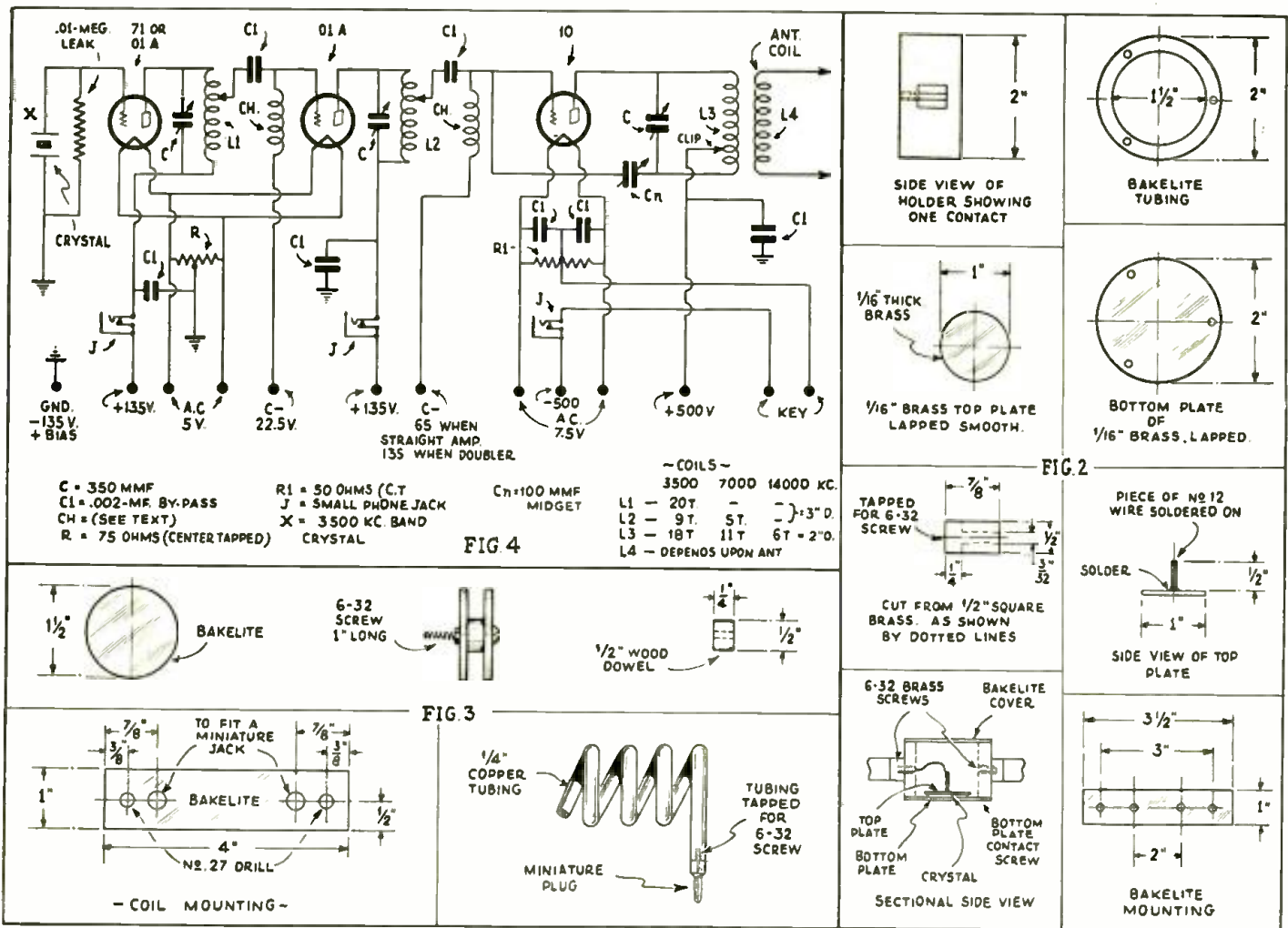

In the drawings above Fig. 1 shows layout for bakelite strips used to support buffer and amplifier coils. Fig. 2—various details in the construction of a crystal-holder. Fig. 3—form for winding grid chokes. Fig. 4—hook-up of parts in the complete transmitter, with crystal-control indicated at extreme left.

mitter were purchased separately as the ones used in the old receiver were not usable. The sockets are mounted and our attention turned to the two grid chokes that are used in the buffer and last stage grid circuits. Four pieces of bakelite 1 and 1/2 inches in diameter and two pieces of 1/2 inch wooden dowel rod 1/4 inch long are used in the construction of the forms as shown in Fig. 3, and are wound with No. 28 cotton covered wire until full, this was done by clamping a hand drill into the jaws of a vise, putting the mounting screw of the chokes into the chuck of the drill and turning the handle until the forms were full of wire. One of the completed chokes is fastened to the grid terminal of each one of the two grid terminals by one inch brass angles.

The crystal-holder is of the dust proof type, although any other type would work as well with a little cleaning now and then. The construction is completely covered by the drawings (Fig. 2) and does not need any further explanation.

Three midget closed circuit jacks are used in series with each plate lead, doing away with the added expense of separate plate meters.

All of the wiring with a few exceptions, is of No. 12 buss-bar and is covered with spaghetti wherever that may be needed.

Preparing the Piezo Plate

Excellent oscillating blanks may be obtained at a very reasonable cost.

The grinding of a quartz crystal is itself not a difficult task, but one in which some care and attention must be exercised. A few hours of your spare time spent in grinding the blank will reward you with a crystal of superior oscillating qualities. You will find that the actual work of grinding is not necessarily hard and that the crystal can be finished within two or three hours.

A few aids necessary for the grinding of the quartz blank:

- 1 small sheet of plate glass.
- 1/4 lb. No. 60 to No. 100 carborundum.
- 1/4 lb. FFF carborundum.
- 1 Carborundum Stone.
- 1 Micrometer.

Examine the blank carefully and you will find that one side is marked as a reference side. You will also find by measuring with a micrometer that the two plane surfaces are parallel to within a fraction of a thousandth of an inch. This is absolutely necessary to obtain easy oscillation from a crystal. This error of tolerance becomes smaller as the crystal becomes thinner. Remembering this, let us get down to the actual grinding procedure. First, you must decide to what frequency you desire to grind the crystal blank. In determining this, remember that this final thickness is dependent upon the cut. The parallel cut is a thinner crystal than the Curie cut for a given frequency. Due to this fact the parallel cut has become known to the amateur fraternity as the thin cut and the Curie as the thick cut. Your blank is clearly

marked to aid you in this computation. For amateur use there is no advantage in the use of one cut over the other with the exception of the 40 meter crystal in which instance the Curie cut is to be recommended due to its added thickness. The following formulae will give the approximate thickness of your finished crystal:

	For the	
For the Curie cut	Parallel Cut	
$t = \frac{112.6}{f}$	$t = \frac{77.0}{f}$	

Where the thickness in inches is (t) and (f) the frequency in kilocycles.

Now when you have determined this thickness, you must proceed to cut down the comparatively thick blank to within five thousandths of an inch to the final thickness. This is done by the use of rough abrasive. Place a slight amount of coarse abrasive on the plate glass with enough water to obtain the consistency of a paste.

GRIND ON THE SIDE WHICH IS NOT MARKED REFERENCE SIDE.

Grinding Crystals

Grinding is accomplished by rubbing the crystal in the mixture of water and abrasive in a rotary motion. Pressure can be applied to the crystal either by the forefinger or by using the rubber on the end of a pencil. Pressure should be applied as nearly as possible to the center of the crystal

(Continued on page 743)

New ALL-WAVE Set

Features Quadri-Color Tuning Scale

This receiver has been thoroughly tested by the editors and has been found to give full speaker volume on the "foreign" stations, under average conditions. In fact, short-wave-stations can be brought in with volume equal to those received on the American broadcast band.

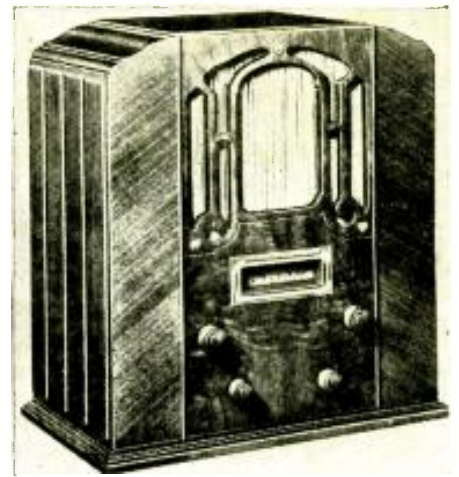
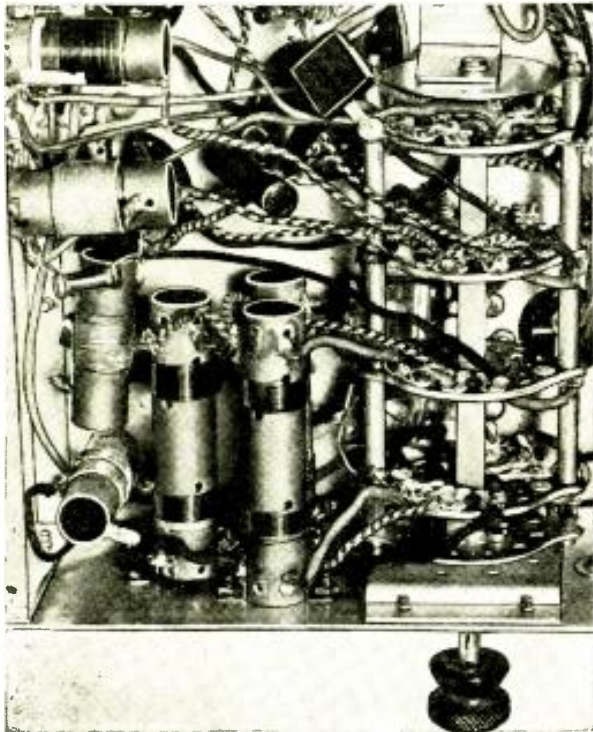

Table model of American-Bosch all-wave set—a knob changes the dials each time a wave band is selected.



Bottom view showing the coil selector switch and how the various coils are mounted.

● HERE is a new *all-wave* radio receiver housed in very beautiful cabinets, which lend themselves easily to the most modern home. Not only are these sets beautiful in appearance but they have some very desirable features, such as the use of new double-duty tubes; tubes that perform the functions of two tubes, making a set consisting of seven tubes equal to one having two or three additional tubes.

A new simplified band-switching system which has been worked out by the American-Bosch engineers, eliminates the "bugs" usually encountered in ordinary band-switching arrangements, and is incorporated in this receiver. The band-switching arrangement is mechanically connected to and controls the multi-tuning scale. This scale arrangement consists of four accu-

rately calibrated scales marked off in megacycles. Each scale has a different color and appears behind the scale window as the band-switching control is adjusted. In other words, if you set the band-selecting switch, a scale calibrated for the tuning range of that band automatically appears behind the window. The 20 to 8 megacycle scale is green, the 9 to 3 megacycle scale is red, the 4 to 1.6 megacycle is green and 1.5 to .55 scale is black. The black scale is for the regular broadcast band and the other three scales are for the various short-wave broadcast bands. This is a very unique arrangement and eliminates cluttering up a single scale with a great number of markings necessary for covering the entire short-wave spectrum and difficult to read quickly.

The tube line-up of the receiver as shown in the accompanying diagram is as follows: The 58 first detector which has a pre-selector between it and the antenna, practically eliminates *image* response. There are two stages of intermediate frequency amplification using 58 tubes. The components of the intermediate frequency amplifier are so shielded that maximum gain can be

(Continued on page 748)

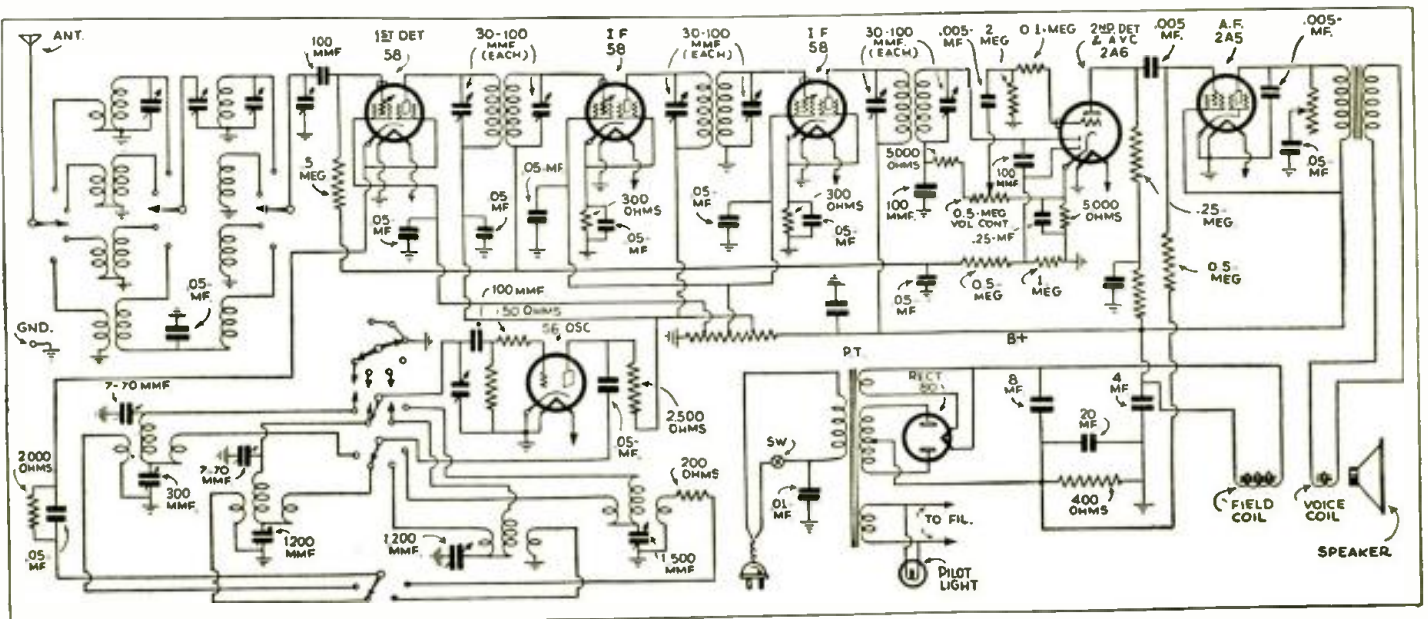

Schematic wiring diagram of the "All-Wave" American-Bosch Receiver.

SHORT WAVE SCOUTS

● The editors are very happy to present the *second* SHORT WAVE SCOUT "Trophy Cup" to Mr. John Sorenson, who contributed the longest list of short-wave stations heard, both verified and unverified, submitted by the closing date of this issue, February 1. In many ways, this is one of the most interesting entries that the editors have ever received in any contest, as it, in a way completely upsets many of the theories advanced by some of our best short-wave "sharks". You will probably be as greatly surprised as the editors were, when you note that Mr. Sorenson rolled up his astonishing list of short-wave stations from all parts of the world, and which he piled up, not on a special short-wave receiver, but on a 11-tube "broadcast" receiver (200 to 550 meter range) used in conjunction with a National short-wave converter.

It has been claimed by some short-wave experts, it is true, that a good short-wave converter, such as the National, for example, used in conjunction with a good quality broadcast receiver should be able to give a good account of itself, and certainly this combination has come through with "flying colors" in Mr. Sorenson's case. One of the arguments in favor of a "receiver set-up", such as that used by Mr. Sorenson, lies in the tremendous amplification obtained from the many amplification stages involved in such an arrangement—in this case, 16 tubes—which actually formed a short-wave superheterodyne; the various R.F. stages in the broadcast receiver acting as the *intermediate amplifier* stages of a superhet, the frequency changing functions having been taken care of in the short-wave converter.

We believe all of our short-wave fans will join in saluting John Sorenson for his very fine list of stations and the accurate and precise way in which he presented them. We present Mr. Sorenson's "log" below, and also, the log submitted by Harold W. Hansen, of South Omaha, Nebraska, whom we are pleased to award Honorable Mention.

JOHN SORENSON WINS JANUARY "TROPHY CUP"

● I HAVE been truly a SHORT WAVE SCOUT this month. You will notice many of the stations from the same country, have been "logged" the same day, for I have found that when one station comes in good, others from the same place, or country, also come in good the same day as a general rule.

Most of the stations submitted have been "logged" many times during the month. United States stations are the hardest of all to "log": by that I mean on 16-19-25-31 meters at the present time. You will notice WSXK (19 meters) is not logged, nor any other U. S. station on 19 meters; only 2 on 25, one on 16 meters and but few above 50 meters. VE9DR, VE9JR, VE9CL, VE9CS, W1XAZ, W1XAL, and others have not been heard by me for many months. I used a 1931 model 11-tube Philco "broadcast" set (200 to 500 meter range), hooked up with a 5-tube National Short-Wave Converter. All stations were brought in on the "loud-speaker" and a 34 foot inside aerial only was used! Verification cards sent with entry.

JOHN SORENSON,
5 Oak Avenue,
Bronx, New York City.

Entry for SHORT WAVE SCOUT Award

- 1—VE9GW—49.22—Bowmanville, Ont., Can.
- 2—VE9DN—49.9—Drummondville, Que., Can.
- 3—COC—49.96—Havana, Cuba—4 to 6 p.m.
- 4—WSXK—25.26—Pittsburgh, Pa.
- 5—W8XK—48.84—Pittsburgh, Pa.
- 6—W9XAA—49.34—Chicago, Ill.
- 7—W3XAI—49.5—Phila., Pa.
- 8—W3XAU—31.28—Phila., Pa.

*See letter on these stations heard best Thursday, Friday and Saturday, 9-12 p.m., talking to KJTY and KJTY talking back. These stations are testing and relaying also. Also testing with Honolulu and California.



SECOND "TROPHY CUP" WINNER

Presented to
SHORT WAVE SCOUT
John Sorenson

For his contribution toward the advancement of the art of Radio by



Magazine

● ON this page is illustrated the handsome trophy, which was designed by one of New York's leading silversmiths. It is made of metal throughout, except the base, which is made of handsome black Bakelite. The metal itself is quadruple silver-plated, in the usual manner of all trophies today.

It is a most imposing piece of work, and stands from tip to base 22 1/2". The diameter of the base is 7 3/4". The diameter of the globe is 5 1/4". The work throughout is first-class, and no money has been spared in its execution. It will enhance any home, and will be admired by everyone who sees it.

The trophy will be awarded every month, and the winner will be announced in the following issue of SHORT WAVE CRAFT. The winner's name will be hand engraved on the trophy.

The purpose of this contest is to advance the art of radio by "logging" as many short-wave commercial phone stations, in a period not exceeding thirty days, as possible by any one contestant. The trophy will be awarded to that SHORT WAVE SCOUT who has logged the greatest number of short-wave stations during the month for which the award is made.

- 9—VE9HX—49.1—Relays CHNS, Halifax, Nova Scotia.
- 10—WES—31.74 m.—Testing with LSX*
- 11—WFF—31.6 m.—Testing with KJTY*
- 12—W2XBL—31.6—31.74—28.98 m.*
- 13—KJTY—38.85—31.6—28.98 m.*
- 14—W2XE—49.02 m.—Atlantic Broadcasting Corp., Wayne, N. J.
- 15—W2XE—25.36 m.—Atlantic Broad. Corp.
- 16—W3XI—17.1—Bound Brook, N. J.
- 17—W3XL—46.7—Bound Brook, N. J.
- 18—W3XAL—49.18—Bound Brook, N. J.
- 19—W3XAI—16.87—Bound Brook, N. J.
- 20—W2XAF—31.48—Schenectady, N. Y.
- 21—W8XAI—49.5—Cincinnati, Ohio.
- 22—W9XF—49.18—Chicago, Ill.
- 23—W4XB—49.7—Miami, Fla.
- 24—W0A—44.41—Lawrenceville, N. J.
- 25—KEE—38.85—California.
- 26—W6XI—38.85—California testing KOKO—HEAD and Point Race and Riverhead, etc.
- 27—KNRA—45—California.
- 28—K6NO—38.85—Honolulu testing with Rycrehead, L. I. KEE
- 29—HJ1ABB—46.5—Baranquilla, Col., S. A.
- 30—HJ4AB—41.6—Manizales, Col., S. A.
- 31—HJ5AB—46—Call, Col., S. A.
- 32—PRADO—45—Riobamba, Ea., S. A.
- 33—HC2RL—45—Quayaquil, Ea., S. A.
- 34—PSK—36.65—Rio Janeiro, Brazil, S. A.
- 35—HJCB—73—Quito, Ea., S. A.
- 36—YV1BC—49—Caracas, Venezuela, S. A.
- 37—YV3BC—48.8—Caracas, Venezuela, S. A.
- 38—CP4—32—La Paz, Bolivia, S. A.
- 39—CP5—49.3—La Paz, Bolivia, S. A.
- 40—LSX—28.9—Buenos Aires, Argentina, S. A.
- 41—HIZ—47.5—San Domingo, W. I.
- 42—HIX—50—San Domingo, W. I.

EUROPE

- 43—GSA—49.6—Daventry, England.
- 44—GSB—31.53—Daventry, England.
- 45—GSC—31.5—Daventry, England.
- 46—GSD—25.5—Daventry, England.
- 47—GSE—25.3—Daventry, England.
- 48—GSG—16.8—Daventry, England.

- 49—G6RX—69.44—Rugby, England.
- 50—GBE—69.44—Rugby, England.
- 51—GBW—20.7—Rugby, England.
- 52—GCW—30.6—Rugby, England.
- 53—DJA—31.4—Zeeseu, Germany.
- 54—DJC—49.83—Zeeseu, Germany.
- 55—DJH—25.5—Zeeseu, Germany.
- 56—DJB—16.8—Zeeseu, Germany.
- 57—DFB—16—Zeeseu, Germany.
- 58—FYA—25.2—France.
- 59—FYA—19.65—France.
- 60—I2RO—25.4—Italy.
- 61—PHH—25.6—Huisen, Holland.
- 62—CP1AA—31.25—Lisbon, Portugal.
- 63—HBP—Geneva, Switzerland—38.47 m.
- 64—HBL—31.27—Geneva, Switzerland.
- 65—EAQ—30.4—Madrid, Spain.
- 66—RV59—50—Moscow, U. S. S. R.
- 67—CNR—37.33—Rabat, Morocco.
- 68—XAM—26—Mexico.
- 69—XAM—52—Mexico.
- 70—VK2ME—31.28—Australia.
- 71—VK3ME—31.55—Australia.

"HONORABLE MENTION" GOES TO HAROLD HANSEN

Editor, SHORT WAVE CRAFT:

I am enclosing my list of stations for the contest which closes February 1, 1934. These stations were received after I received my February issue of SHORT WAVE CRAFT on January 19. So I am sending my list, verifications, and statement (sworn to before a notary public) in one envelope. I haven't a very large list but have tried to conform to the rules. I am using a National SW-45 receiver, with a single-wire antenna. You will find my list on a separate sheet. In accordance with your latest rules the oath testifying to the fact that I received these stations personally without the assistance of anyone else on my own receiving set is attached.

(Continued on page 760)

WHAT'S NEW

In Short-Wave Apparatus

The short wave apparatus here shown has been carefully selected for description by the editors after a rigid investigation of its merits.



A revelation indeed is the powerful "loud speaker" reception of "DX" stations on this 16-tube Midwest All-Wave receiver. (No. 147.)

● THE 16-tube *Midwest* receiver shown in the photograph was thoroughly tested by the writer and gave fine results on some of the most distant stations. It was possible to drive a large dynamic speaker to full volume on stations located in South America, Central America, and practically

every prominent short-wave station in Europe. Some of the outstanding features of this receiver are the *automatic volume control* and the very efficient *band-switching* arrangement. It is possible to tune in stations from 10 to 2,000 meters. This means that the regular broadcast (200 to

"Foreigns" Roll In on 16-Tube Receiver

550 meter) band is covered, together with the low frequency band on which can be heard airplane beacon messages, ship-to-shore communication, and the long wave "press" hook-ups. For those who copy the code, the low frequency band will provide almost as much enjoyment as listening to foreign short-wave broadcasting (phone) stations. The "old-timer" will never tire of listening to ship-to-shore conversations.

On multi-tube *high-gain* receivers such as this, the *tone control* is one of the most valuable features that could be incorporated in a receiver. This set was tested in a very noisy location where automobile ignition interference, electrical motors, etc., practically ruin short-wave reception. However the *tone control*, when properly adjusted, served to practically eliminate this type of interference and allowed the station to come through with perfect clarity and normal volume. When the tone control was adjusted so as not to discriminate against the high frequency response, the background noise nearly drowned out the station. In other words, it would have been a total loss if it were not for this efficient tone filter arrangement. Each one of the wave bands covered by this receiver has a separate scale on the dial, which is calibrated in megacycles for the short-waves and kilo-

(Continued on page 755)

A TRF Pre-Selector for S-W Super-hets

● THIS pre-selector, a recent addition to the well-known National line of short-wave apparatus, was designed particularly for operation in conjunction with the National FB-7 series receivers. However, it can be used in conjunction with practically any short-wave superheterodyne receiver. It is enclosed in a neat crackled finish metal cabinet and has the well-known National design "front panel" plug-in coil, which can be seen by glancing at the photograph to be located beneath the main tuning dial. For superhet receivers not having a tuned R.F.

stage ahead of the first detector this pre-selector affords a positive relief from *image interference*. It also enables the operator to bring in *weak* stations with greater volume, due to the considerable amount of gain affected by this additional tuned R.F. stage.

Leads for the filament and plate voltages are brought out in order that the same power supply can be used for both the receiver and the pre-selector unit. A separate wire is also brought out for connection to the volume control. The input to the pre-selector is so arranged that the same

antenna system can be used. The terminals marked A and G in the diagram are connected to the antenna coil to the first detector in the superheterodyne. One side of this coil should then be connected to the B plus lead of the power supply. This will furnish plate voltage for the 58 R.F. tube. However, there should be no connection between the antenna coil and the B negative of the chassis, otherwise a short-circuit will be the result.

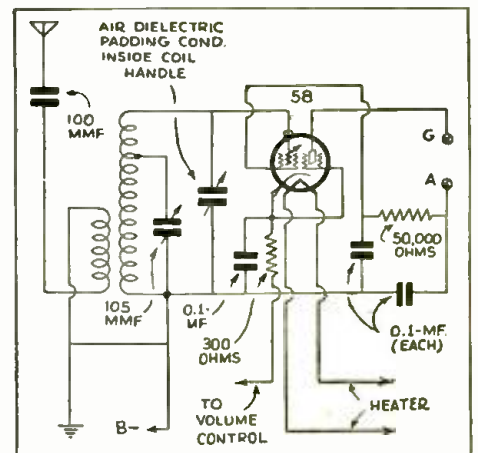

Appearance (left) and diagram (above) of the new National TRF Pre-Selector, for use ahead of the FB7 or other Super-hets (No. 148.)

(Names and addresses of manufacturers furnished upon receipt of stamped envelope; mention No. of article.)

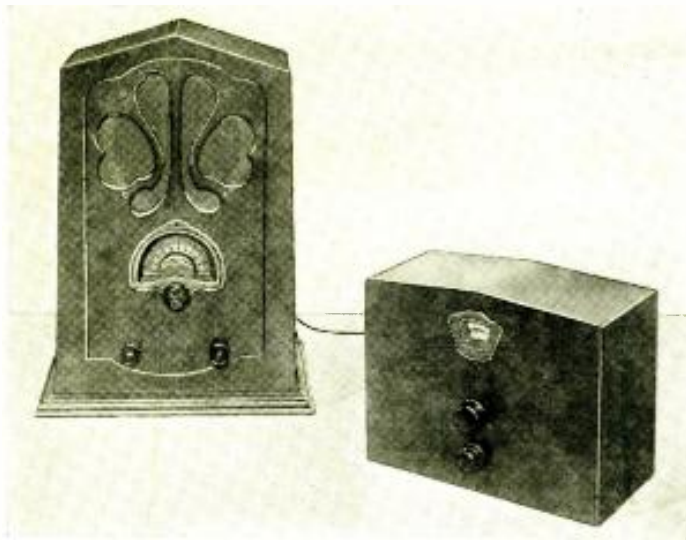

Some very fine S-W reception has been obtained with this converter. (Instrument at right of photo.)

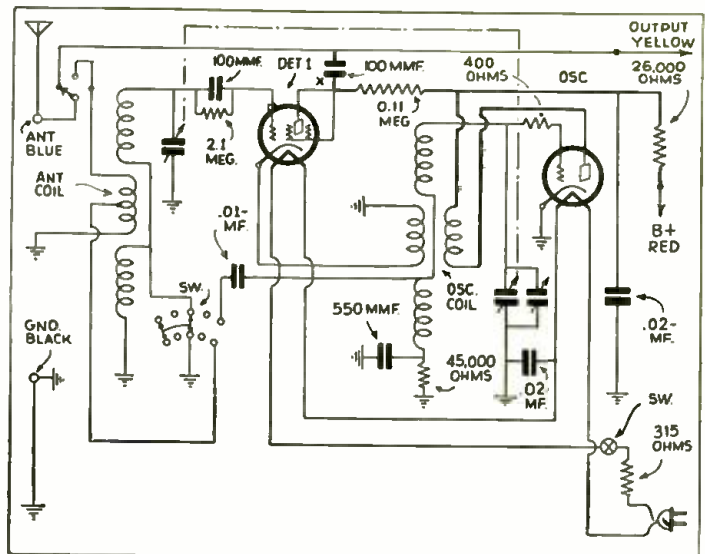

Wiring diagram of the short-wave converter. (140.)

A New 2-Tube Short-Wave Converter

● FOR those that have a regular broadcast receiver (200 to 550 meters) not equipped with a short-wave attachment, this converter provides an excellent source of entertainment from the various short-wave programs originating in this and foreign countries. There are literally hundreds of stations broadcasting very interesting programs over the short waves and it is quite possible with

this converter to receive stations located in the most remote portions of the earth. This is not an autodyne type converter; two separate tubes are used, one as the first detector, and another as the high-frequency local-oscillator which changes the incoming frequency to that of the broadcast receiver. The model shown above uses a 36 screen-grid tube as the first detector and a 37 as oscillator with

their filaments connected in series. The 110 volt line, either A.C. or D.C., is fed to the two tubes through a suitable potential dropping resistor which reduces the line voltage to a value suitable to light the filaments of the tubes. The two tubes in series require 12 volts. This dropping resistor is contained directly in the line cord, which plugs into
(Continued on page 745)

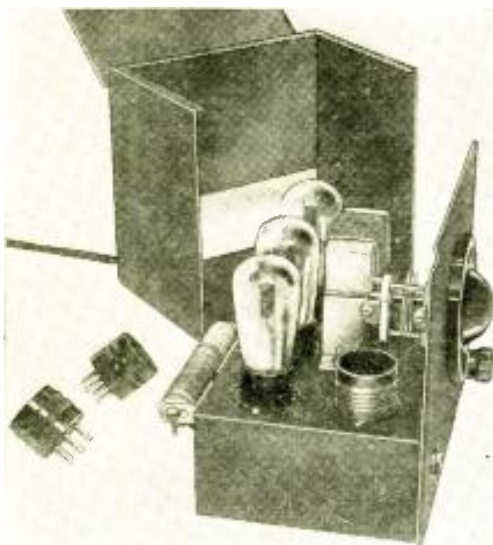

Here's Mr. Victor's A.C. Monitor, removed from its metal cabinet.

● THE monitor is a much abused little piece of equipment that is actually indispensable around the "ham shack." Since the new Federal Radio Commission rulings it is practically suicide for even an xtal controlled station to go on the air without one. For, even in the best of stations things will go wrong, and if monitors are good enough for the broadcast stations they should be good enough for the ham.

What is a monitor, and what is its function, the uninitiate will ask? Well, this little gadget is a totally shielded receiver designed just to listen to the "home" station. It is really a very

A. C. Monitor for "Hams" and Short-Wave Listeners

By Leonard J. Victor

stable oscillating detector circuit, fully enclosed or shielded, so that it picks up nothing but the strong local signal from the home transmitter. After the transmitter's signal has been picked up, the monitor reverses its rôle and becomes a miniature xmitter. It sends out a weak whistle that can be heard in the receiver. Listening to the note from the monitor (which is on the same frequency as the transmitter), it is possible to tell just where the xmitter is operating, whether it is in or out of the ham band, and whether the transmitter is sending on the same frequency as some other station. Reversing the process, it is possible to set the transmitter in any particular spot desired in the band, especially a spot on which there isn't anyone else sending—if there is such a thing still possible!

This procedure is necessary as the "home" transmitter will completely block the receiver, and nothing will be heard but a loud thumping noise, all over the dial.

Most monitors are one-tube battery affairs, and because of this they cannot be used constantly. Constant-monitoring, that is, listening in on your transmitter all the time the station is on the

air, is a very worth-while thing. It will tell whether your "keying" is ok, and give due warning when something starts going wrong with the transmitter.

The problem to hand was to make up a unit that would be suitable for constant operation. This seemed best.

(Continued on page 744)

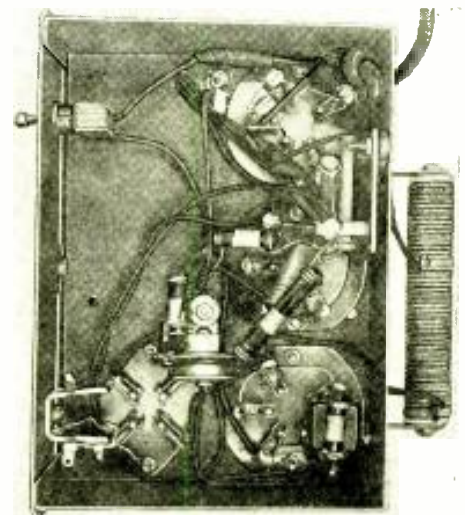

Bottom view of the A.C. Monitor.

(Names and addresses of manufacturers furnished upon receipt of stamped envelope; mention No. of article.)

The 1-Tube Short-Wave SCOUT

By H. W. SECOR

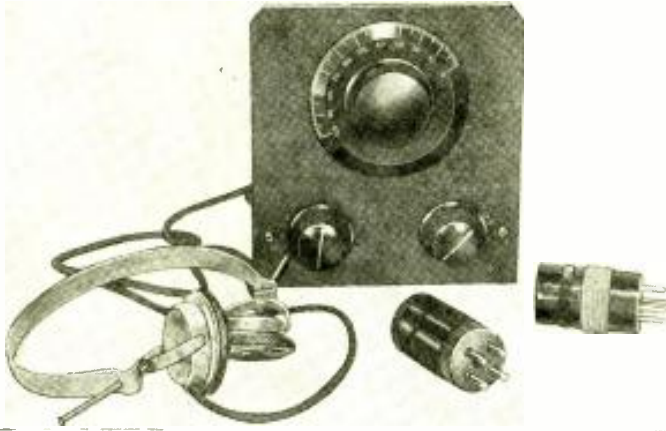

The appearance of the 1-tube short-wave "Scout", which uses "plug-in" coils and phones, is shown in the photo at the left. (No. 150.)

is used with a 100 mmf. grid condenser and a 5 megohm grid-leak, which provides for very smooth regeneration control. (Continued on page 749)

● The 1-Tube Scout is primarily intended for the newcomer to the ranks of short-wave fandom. This receiver uses one type 30 two-volt battery tube, in the standard regenerative detector circuit. This is one of the most simple forms of short-wave receivers, and it is recommended that those just becoming acquainted with short-waves build a set of this type in order to acquaint themselves thoroughly with the operation and handling of a short-wave receiver.

The entire receiver is constructed on a 4"x6"x2½" chassis with a 6"x6½" metal panel. The main tuning condenser which is a .00014 mf. midget condenser is mounted directly in the center of the panel. The filament

rheostat is located on the lower right-hand side of the panel with the regeneration control potentiometer mounted on the lower left-hand side of the panel. Phone terminals, also antenna and ground connections are brought out on the rear of the base. The antenna trimming condenser which is a 100 mmf. low-minimum, variable "postage-stamp" condenser is also mounted on this part of the chassis. The four-wire cable is brought out directly through the center of the rear of the chassis. Looking at the rear view photograph at the right, the 230 tube is mounted to the left, and the plug-in coil fitted on the right-hand side.

Looking at the wiring diagram, we find that standard grid-leak detection



Rear view of the 1-tube "Scout" receiver.

Why Battery-Operated S-W Sets Are Better

By C. W. PALMER

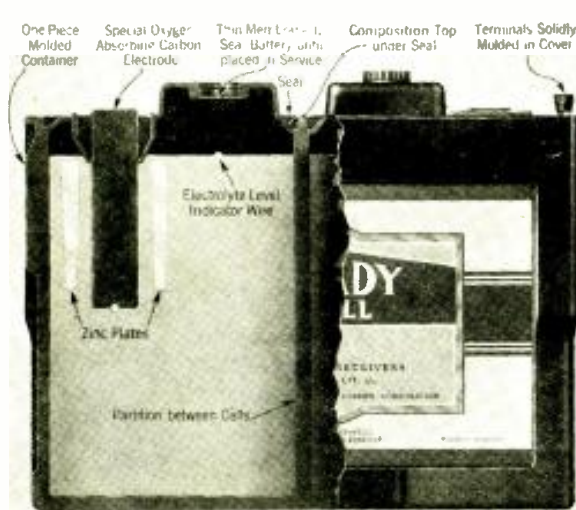

Appearance of latest type 2 volt "Air-Cell" battery, with particularly long life. (No. 151.)

tion of short waves is the ease with which great distances can be consistently surmounted.

Thus, the question narrows itself down to three comparatively simple points. They are: *quietness of operation, convenience and cost.*

Battery Sets More Quiet

It is a well-known fact, and one that is conceded by even the most rabid power-operation advocate, that battery-operated S.W. sets are more quiet in operation than A.C.

sets, especially on the higher frequencies. And this is an important point, as it often determines whether a far distant station can be "pulled-in" above the noise level. Naturally, even a slight increase in the noise level becomes extremely annoying, especially when you are trying to get the last "ounce" of amplification out of a set.

Thus, for the most efficient operation, battery operation is to be preferred.

Convenience of Operation

The second major point mentioned above is *convenience*. It must be admitted that it is very handy to simply turn a switch and know that your short-wave receiver will be ready for operation, without having to worry about the condition of batteries.

(Continued on page 750)

● **THROUGHOUT** the development of short-wave reception to its present status, a long-standing argument has been carried on between various experimenters and designers of radio receivers. This is the question of which is better—battery or power operation of short-wave sets?

The result of a survey of all the available printed arguments pro and con and the verbal statements of practically every short-wave enthusiast known to the writer has netted the following conclusions. The chief attrac-

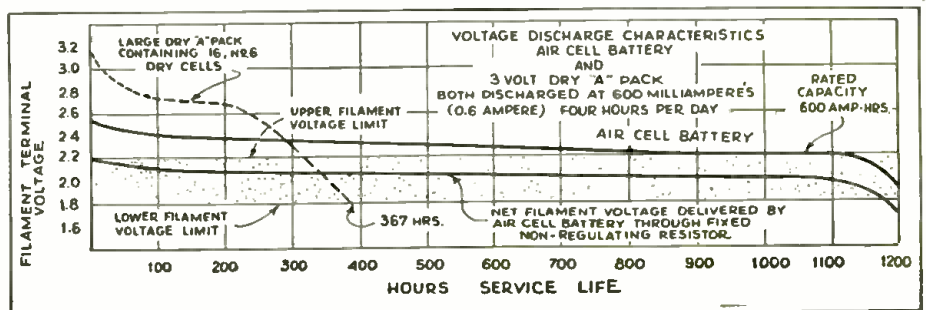

Voltage discharge curves for "Air-Cell" battery and 3 volt dry "A" pack.

(Names and addresses of manufacturers furnished upon receipt of stamped envelope; mention No. of article.)

SHORT WAVE LEAGUE



HONORARY MEMBERS

- Dr. Lee de Forest
- John L. Reinartz
- D. E. Replugle
- Hollis Baird
- E. T. Somerset
- Baron Manfred von Ardenne
- Hugo Gernsback
- Executive Secretary*

The Best "No Code" Argument Yet

Editor, SHORT WAVE CRAFT:

● THE writer has noticed in past issues of SHORT WAVE CRAFT many good, and some not so good arguments for and against the elimination of a "code test" on the five meter amateur band. It appears that licensed amateurs seem to be almost unanimously opposed to the idea, although it is the writer's contention that they would actually benefit by such an arrangement. The writer is in favor of the following changes in the existing regulations for a license to operate a phone station in the five meter band only:

For Five Meters Only:

- 1.—Eliminate code test.
- 2.—Stiffen "technical" examination.
- 3.—Prohibit use of "modulated" oscillators.

In justifying these changes, consider for a moment the 80 meter phone band, which is 100 kc. wide, extending from 3900-4000 kc. Let's make a few assumptions and assume that the average 80 meter phone transmitter has an effective range of 1000 miles and that within any 1000 mile circle of the United States, there are on the average 1000 80 meter phones, or in other words 10 phones per kc. It appears to the writer that these are very conservative assumptions.

Now, let's assume that the above changes are made in the existing regulations for phone operation on five meters. The average range of a five meter transmitter is certainly not more than 50 miles, and if we can get three 1,000 mile circles in the United States, we can easily get 1,000 50-mile circles in the same area. Hence, for the same congestion we assumed on the 80 meter band, namely, 10 phones per kc., we can have 40,000 stations in a 50 mile circle on five meters, since the five meter band is 4,000 kc. wide. In the whole United States, we could have $40,000 \times 1,000$ or 40,000,000 5-meter phones, operating with no more

● MR. J. A. WORCESTER, Jr., a graduate Electrical Engineer, and also a licensed "Ham," call W2GAU, inventor of the "Oscillodyne" and other S.W. circuits, has, like a bolt from the blue, here presented the clearest and most logical arguments imaginable for granting 5-meter "phone" licenses, without a code test, that we have yet seen.

bedlam than now exists on the 80-meter band! Since there are only 40,000 licensed amateurs and not more than 200,000 short-wave listeners, there is but little likelihood that an impossible chaos would result; even admitting that anything like uniform distribution of the total number of stations over the United States would be impossible.

The writer would like to emphasize that this assumes that modulated oscillators, such as are now in common use on this band, are prohibited! This would necessitate the junking of broad tuning, "super-regenerative" receivers, with their accompanying noise and insensitivity. Contrary to general belief, there is no great difficulty involved in building a M.O.P.A. (master oscillator-power amplifier) outfit for five meter transmission, nor in building R.F. amplifiers or super-heterodyne receivers for five meter reception, once there is some in-

centive for doing so. Having attempted to show above that it is unlikely that eliminating the code test on five meters will result in excessive interference, the writer would like to further indicate that this procedure may easily result in a reduction in the chaos to which the phone amateur is now subjected. There can be no doubting the fact that a large number of amateurs now on the 80 and 160 meter bands would go down to five meters, if they could find someone to talk to. It is impossible to carry on an intelligent conversation with an "automobile ignition system," which is about all that can now be heard on five meters, in all but the more thickly populated cities. If more stations were operating in the five meter band more amateurs now on 20 and 80 and 160 meters would go down, thus alleviating to a considerable extent the congestion now existing on these bands.

There is still another way in which opening the five meter band to short wave listeners who pass a suitable technical examination can benefit existing amateurs. A certain amount of "bedlam" has come to be expected on the amateur bands, and it will only be a matter of time before the fathers-that-be, after noting the peace and quiet existing on the five meter band, will arrive at the conclusion that the amateurs can get along with 500 kc. or less, just as well as on 4,000 kc. as at present. Don't get the idea that this is all "idle twaddle". It has been done before and will undoubtedly be tried again, just as soon as commercial television interests start clamoring for more territory. If such an occasion arose today, it would be very difficult indeed for the amateurs to justify a 4,000 kc. band at this frequency. The only way to hold on to present territory is to show suitable occupancy, which can't be shown at present, in spite of the fact that the five meter band has been open for several years!

(Continued on page 753)

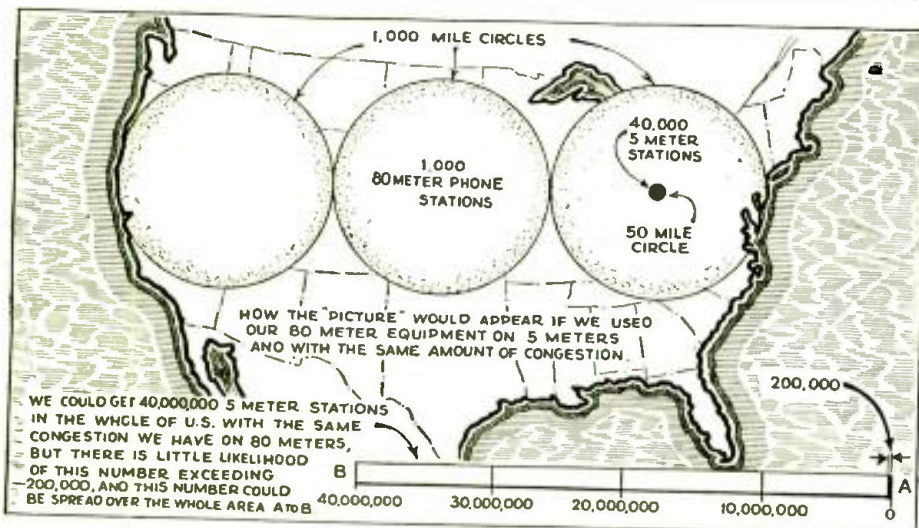

Get Your Button

The illustration herewith shows the beautiful design of the "Official" Short Wave League button, which is available to everyone who becomes a member of the Short Wave League.

The requirements for joining the League are explained in a booklet, copies of which will be mailed upon request. The button measures 3/4 inch in diameter and is inlaid in enamel—3 colors—red, white, and blue.



Please note that you can order your button AT ONCE—SHORT WAVE LEAGUE supplies it at cost, the price, including the mailing, being 35 cents. A solid gold button is furnished for \$2.00 prepaid. Address all communications to SHORT WAVE LEAGUE, 96-98 Park Place, New York.

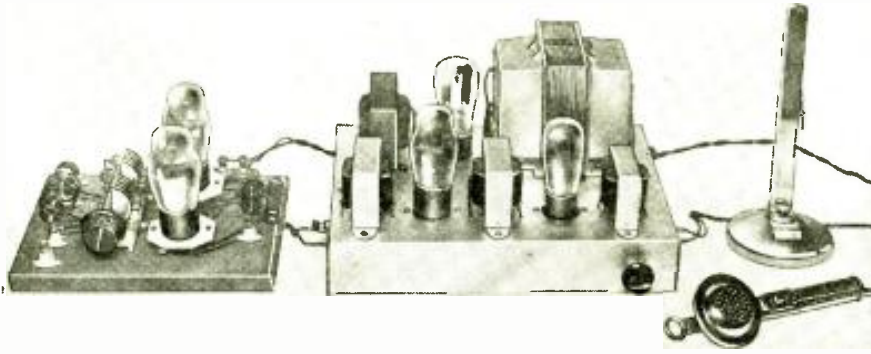

General view of the oscillator-modulator set up ready for operation.

This 5 meter transmitter uses either 12A or 71A oscillator tubes in a push-pull oscillator circuit and is modulated with a class "B" modulator, using a 53 twin tube. The modulator unit also supplies the plate voltage for the oscillator. This little 5 meter transmitter is capable of working practically every station that can be heard on the 5 meter band.

The R. T. 5 METER TRANSMITTER

• THE five-meter radiophone transmitter shown in the photographs uses receiving type tubes throughout and yet it is capable of emitting a surprisingly "husky" signal. Distances up to 35 miles have been covered with this little outfit and it has proven entirely satisfactory under all conditions. All stations worked from the writer's location with the high-power transmitter shown in the Jan., 1934, issue, were worked with the above transmitter and in many cases the signal strength was reported the same!

The tubes used in the push-pull oscillator circuit are 112A's or 171A's. The 112A's seem to be the best oscillators and are much steadier in operation. The plate power input should not exceed 22.5 watts (300 volts at 75 mills). With this input the tubes were left running for hours at a time during "duplex" QSO's, with not the slightest signs of heating or injury to the tubes. The value of the grid-leak used is very important; at least 30,000 ohms should be used in order to keep the plate cur-

rent low—and allow of easier modulation.

With no antenna load the plate current will be between 50 and 55 mills (M.A.), depending upon the adjustment of the grid coil.

The grid coil should always be adjusted to a point that gives the lowest plate current at the frequency on which the set is to be operated. Lower values for the grid-leak will cause the plate current to be high and will result in inefficiency and damage to the tubes. These are the two most important points to remember when using receiving tubes as oscillators with high plate voltage—*proper adjustment of the grid coil and right value of grid resistance!*

rent low—and allow of easier modulation.

Plate Tuning Capacity Important

Another thing that affects the

efficiency of the oscillator is the value of the capacity used to tune the plate circuit. If too few turns are used in the plate coil the necessary capacity to tune to the five-meter band will be too high, causing the plate current to be high and permitting less R.F. output at a given plate input; this results in the tubes running too hot and shortening their lives. The best size coil to use is 4 turns, one-inch in diameter, and with about 1/4 inch spacing between turns. The grid and plate coils are wound with number 12 enameled antenna wire. The grid coil consists of six turns 1/2 inch in diameter and spaced 1/8 inch between turns. With the above plate coil the plate tuning capacity will be of optimum (best) value. The tuning condenser is of the double-spaced split-stator type having a capacity of 35 mmf. per section with isolantite insulation. Isolantite sockets and stand-off insulators should be

(Continued on page 753)

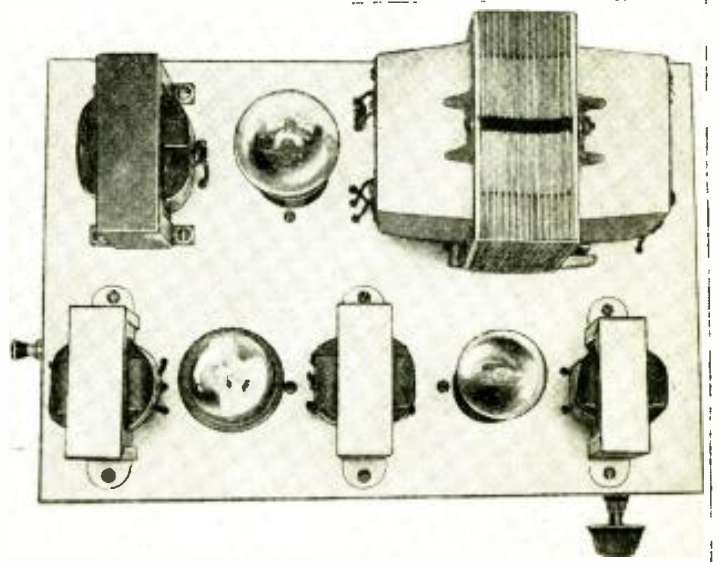
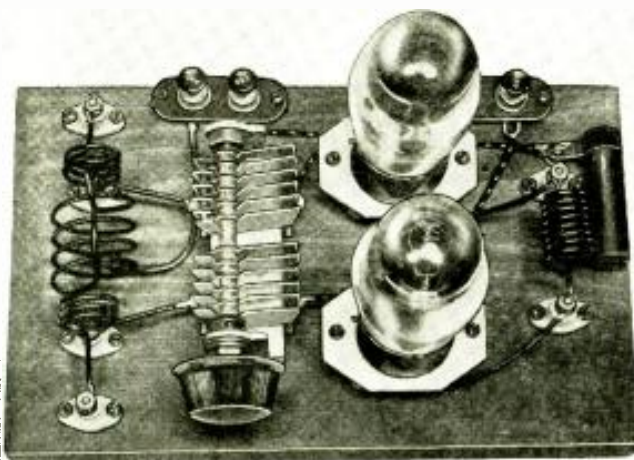

The photograph, to the left, is a close up of the push-pull oscillator; to the right, is the class "B" modulator and power-supply unit.

SHORT WAVE STATIONS OF THE WORLD

SECTION ONE

As promised in the last issue, we are presenting herewith a complete, revised and combined list of the short wave broadcasting, experimental and commercial radiophone stations of the world. This is arranged according to frequency, but the wavelength figures are also given for the benefit of readers who are more accustomed to working with "meters" than with "kilocycles". All the stations in this list, with one or two exceptions of the time stations, use telephone transmission of one kind or another and can therefore be identified by the average listener.

● WE GO to considerable expense each month to revise this specially compiled list of short-wave stations, and the list is not simply repeated each time, as many readers might assume. In order to aid us in keeping this list as accurate as possible, we will appreciate hearing from short-wave listeners of any omissions or errors in the list as here published.

The March, 1934, issue (copies mailed for 25c) contained a very fine list of police, airport and television stations, which was marked "Section Two". This will reappear in the May issue with the latest corrections and additions. Section One (this month's list) will be published again in the June issue, also with last minute changes. Note: Stations marked with a star (★) are the most active and easily heard stations and transmit at fairly regular times. Stations are classified as follows: C—Commercial phone. B—Broadcast service. X—Experimental transmissions.

Around-the-Clock Listening Guide

Although short wave reception is notorious for its irregularity and seeming inconsistency (wherein lies its greatest appeal to the sporting listener), it is a good idea to follow a general schedule as far as wavelength in relation to the time of the day is concerned. The observance of a few simple rules will save the short wave fan a lot of otherwise wasted time. From daybreak to mid-afternoon, and particularly during bright daylight, listen between 13 and 22 meters (21540 to

13000 kc.). Check the time these stations are broadcasting. To the east of the listener, from about noon to 10:00 p. m., the 20-35 meter will be found very productive. To the west of the listener this same band is best from about midnight until shortly after daybreak. After dark, results above 35 meters are usually much better than during daylight. These general rules hold good whether you live in the United States or in China.

21540 kc. ★W8XK -B- 13.93 meters WESTINGHOUSE ELECTRIC SAXONBURG, PA. 7 a. m.-2 p. m.; relays KOKA programs	19380 kc. WOP -C- 15.48 meters OCEAN GATE, N. J.	18240 kc. FRO,FRE -C- 16.44 meters ST. ASSISE, FRANCE	17120 kc. WOO -C- 17.52 meters A. T. & T. CO., OCEAN GATE, N. J.	15270 kc. ★W2XE -B- 19.65 meters ATLANTIC BROADCASTING CORP. WAYNE, N. J. 11 a. m.-1 p. m., relays WABC
21470 kc. GSH -B- 13.97 meters BRITISH BROAD. CORP. DAVENTRY, ENGLAND British Empire programs	19355 kc. FTM -C- 15.50 meters ST. ASSISE, FRANCE	18200 kc. GAW -C- 16.48 meters RUGBY, ENGLAND	17120 kc. WOY -C- 17.52 meters LAWRENCEVILLE, N. J.	15250 kc. W1XAL -B- 19.67 meters BOSTON, MASS.
21420 kc. WKK -C- 14.01 meters A. T. & T. CO. LAWRENCEVILLE, N. J.	19220 kc. WKF -C- 15.60 meters LAWRENCEVILLE, N. J.	18040 GAB -C- 16.63 meters RUGBY, ENGLAND	17080 kc. GBC -C- 17.56 RUGBY, ENGLAND	15243 kc. ★FYA -B- 19.68 meters "RADIO COLONIAL" PONTOISE (Paris), France Service de la Radiodiffusion, 103 Rue de Grenelle, Paris 8-11 a. m.
21130 kc. LSM -C- 14.15 meters BUENOS AIRES, ARGENTINA	19160 kc. GAP -C- 15.66 meters RUGBY, ENGLAND	17810 kc. PCV -C- 16.84 meters KOOTWIJK, HOLLAND 6:00-9:00 a. m.	16270 kc. WLK -C- 18.44 meters LAWRENCEVILLE, N. J.	15210 kc. ★W8XK -B- 18.72 meters WESTINGHOUSE ELECTRIC & MFG. CO. SAXONBURG, PA. 10 a. m.-4:15 p. m. Relays KOKA
21060 kc. WKA -C- 14.25 meters LAWRENCEVILLE, N. J.	18970 GAQ -C- 15.81 meters RUGBY, ENGLAND	17780 kc. ★W3XAL -B- 16.87 meters NATIONAL BROAD. CO. BOUND BROOK, N. J. 11 a. m.-5 p. m., exc. Fri. Relays WJZ	16270 kc. WOG -C- 18.44 meters OCEAN GATE, N. J.	15200 kc. ★DJB -B- 19.73 meters ZEESEN, GERMANY
21020 kc. LSN -C- 14.27 meters BUENOS AIRES, ARGENTINA	18830 kc. PLE -C- 15.93 meters BANDOENG, JAVA	17770 kc. ★GSG -B- 16.88 meters BRITISH BROAD. CORP. DAVENTRY, ENGLAND British Empire programs	16233 kc. FZR -C- 18.48 meters SAIGON, INDO-CHINA	15140 kc. ★GSF -B- 19.81 meters BRITISH BROAD. CORP. DAVENTRY, ENGLAND British Empire programs
20730 kc. LSY -C- 14.47 meters BUENOS AIRES, ARGENTINA	18680 kc. GAX -X- 16.06 meters RUGBY, ENGLAND	17775 kc. ★PHI -B- 16.88 meters HUIZEN, HOLLAND	15880 kc. FTK -C- 18.90 meters ST. ASSISE, FRANCE	15120 kc. ★HVJ -B- 19.83 meters VATICAN CITY ROME, ITALY 5:00 to 5:15 a. m., except Sunday
20380 kc. GAA -C- 14.72 meters RUGBY, ENGLAND	18620 kc. GAU -C- 16.11 meters RUGBY, ENGLAND	17760 kc. IAC -C- 16.89 meters PIZA, ITALY 6:30-7:30 a. m.	15490 kc. J1AA -X- 19.36 meters Mornings KEMIKAWOA-CHO-CHIBA- KEN, JAPAN	15055 kc. WNC -C- 19.92 meters HIALEAH, FLORIDA
19900 kc. LSG -C- 15.37 meters BUENOS AIRES, ARGENTINA	18370 kc. PMC -C- 16.33 meters BANDOENG, JAVA	17640 kc. Ship. -C- 17.00 meters SHIPS Phones to Shore Work on this and higher channels	15330 kc. ★W2XAD -B- 19.56 meters GENERAL ELECTRIC CO. SCHENECTADY, N. Y. Relays WGY, Mon., Wed., Fri., 2:30-3:30 p. m., Sun., 2-4 p. m.	14590 kc. WMN -C- 20.56 meters LAWRENCEVILLE, N. J.
19820 kc. WKN -C- 15.14 meters LAWRENCEVILLE, N. J.	18345 FZS -C- 16.35 meters Saigon, INDO-CHINA	17310 kc. W3XL -X- 17.33 meters BOUND BROOK, N. J. Fri. 11 a. m.-5 p. m.	15295 kc. CP5 -B- 19.61 meters LA PAZ, BOLIVIA 9:30-10:30 a. m.	
	18340 kc. WLA -C- 16.36 meters LAWRENCEVILLE, N. J.			
	18310 kc. GAS -C- 16.38 meters RUGBY, ENGLAND			

(Time given is Eastern Standard Time)

14530 kc. LSN -C- 20.65 meters BUENOS AIRES, ARGENTINA	11865 kc. *GSE -B- 25.28 meters BRITISH BROAD. CORP. DAVENTRY, ENGLAND British Empire programs	10330 kc. ORK -B- 29.04 meters RUYSSSELEDE, BELGIUM From 1 p. m.	9570 kc. *W1XAZ -B- 31.35 meters WESTINGHOUSE ELECTRIC & MFG. CO. SPRINGFIELD, MASS. 7 a. m.-1 a. m. daily	7880 kc. J1AA -C- 38.07 meters KEMIKAWOA-CHO-CHIBA- KEN, JAPAN
14525 kc. XDA -C- 20.65 meters TRANS-NEWS AGENCY MEXICO CITY 2:30-3 p. m.	11830 kc. *W2XE -B- 25.36 meters ATLANTIC BROADCASTING CORP. WAYNE, N. J. Relays WABC 3-5 p. m.	10300 kc. LSL -C- 29.13 meters BUENOS AIRES	9560 kc. *DJA -B- 31.38 meters ZEESEN, GERMANY	7830 kc. PDV -C- 38.30 meters KOOTWIJK, HOLLAND After 9 a. m.
14470 kc. WMF -C- 20.73 meters LAWRENCEVILLE, N. J.	11810 kc. *I2RO -B- 25.4 meters ROME, ITALY Daily, 12 noon-1:30 p. m., 4-6:30 p. m.	10220 kc. PSH -C- 29.35 meters RIO DE JANEIRO, BRAZIL	9530 kc. *W2XAF -B- 31.48 meters GENERAL ELECTRIC CO. SCHENECTADY, N. Y. Relays WGY programs 7:45-11 p. m. Also from 11 p. m.-Midnight on Saturday	7799 kc. *HBP -B- 38.47 meters LEAGUE OF NATIONS. GENEVA, SWITZERLAND 5:30-6:15 p. m., Saturday
14440 kc. GBW -C- 20.78 meters RUGBY, ENGLAND	11790 kc. W1XAL -B- 25.45 meters BOSTON, MASS. Irregularly in the morning	10055 kc. ZFB -C- 29.84 meters HAMILTON, BERMUDA	9510 kc. *GSB -B- 31.55 meters BRITISH BROAD. CORP. DAVENTRY, ENGLAND British Empire programs	7770 kc. PCK -C- 38.60 meters KOOTWIJK, HOLLAND 9 a. m. to 7 p. m.
13990 kc. GBA -C- 21.44 meters RUGBY, ENGLAND	11760 kc. *DJD -B- 25.50 meters ZEESEN, GERMANY	9950 kc. GCU -C- 30.15 meters RUGBY, ENGLAND	9510 kc. *VK3ME -B- 31.55 meters AMALGAMATED WIRELESS, Ltd. G. P. O. Box 1272L, MELBOURNE, AUSTRALIA Wed., 5:00-7:00 a. m. Saturday, 5:00-7:00 a. m.	7480 kc. GDW -C- 40.11 meters RUGBY, ENGLAND
13585 kc. GBB -C- 22.08 meters RUGBY, ENGLAND	11750 kc. *GSD -B- 25.53 meters BRITISH BROAD. CORP. DAVENTRY, ENGLAND British Empire programs	9890 kc. LSN -C- 30.30 meters BUENOS AIRES	9510 kc. YV3BC -B- 31.55 meters CARACAS, VENEZUELA Irregularly 10:30 a. m.-1 p. m.	7444 kc. HBQ -B- 40.3 meters LEAGUE OF NATIONS, GENEVA, SWITZERLAND
13465 kc. GBQ -C- 22.28 meters RUGBY, ENGLAND	11730 kc. *PHI -B- 25.57 meters HUIZEN, HOLLAND Mon., Wed., Fri., 7:30-9:30 a. m.; Sat., Sun., 7:30-10 a. m.	9870 kc. WON -C- 30.4 meters LAWRENCEVILLE, N. J.	9330 kc. CGA -C- 32.15 meters DRUMMONDVILLE, CANADA	7150 kc. HJ4ABB -B- 41.6 meters MANIZALES, COLOMBIA Various times during evening
13390 kc. WMA -C- 22.40 meters LAWRENCEVILLE, N. J.	11720 kc. *VE9JR -B- 25.6 meters WINNIPEG, CANADA Daily exp. Sun., 6-10:30 p. m.; Sun., 9-10:30 p. m.	9870 kc. J1AA -X- 30.4 meters KEMIKAWOA-CHO-CHIBA- KEN, JAPAN 4-7 a. m., irregularly	9280 kc. GCB -C- 32.33 meters RUGBY, ENGLAND	6990 kc. LCL -B- 42.92 meters JELOY, NORWAY Relays Oslo 11 a. m.-6 p. m.
13210 kc. WOO -C- 22.71 meters OCEAN GATE, N. J.	11705 kc. *FYA -B- 25.63 meters "RADIO COLONIAL" PONTOISE (PARIS) 3-6 p. m., 6:15-9 p. m., 10 p. m.-12 midnight, Daily	9860 kc. *EAQ -B- 30.43 meters MADRID, SPAIN Daily, 5:30-8:00 p. m. Sat., also 1-3 p. m.	9170 kc. WNA -C- 32.72 meters LAWRENCEVILLE, N. J.	6976 kc. EAR110 -B- 43 meters MADRID, SPAIN Tues., Sat., 5:30 p. m.
12840 WOY -C- 23.36 meters LAWRENCEVILLE, N. J.	11680 kc. KIO -C- 25.68 meters KAHUU, HAWAII	9790 kc. GCW -C- 30.64 meters RUGBY, ENGLAND	9170 kc. GCS -C- 32.26 meters RUGBY, ENGLAND	6905 kc. GDS -C- 43.95 meters RUGBY, ENGLAND
12840 WOO -C- 23.36 meters OCEAN GATE, N. J.	11340 kc. DAN -C- 26.44 meters NORDEICH, GERMANY	9750 kc. WOF -C- 30.77 meters LAWRENCEVILLE, N. J.	9020 kc. GCS -C- 32.26 meters RUGBY, ENGLAND	6860 kc. KEL -C- 43.70 meters BOLINAS, CALIF.
12825 kc. *CNR -B, C- 23.39 meters DIRECTOR GENERAL Telegraph and Telephone Stations, Rabat, Morocco Sunday, 7:30-9:00 a. m.	11181 kc. *CT3AQ -B- 26.83 meters FUNCHAL, MADERIA Tues., Thurs., 5:00-6:30 p. m. Sunday, 10:30 a. m.-1 p. m.	9710 kc. GCA -C- 30.89 meters RUGBY, ENGLAND	8920 kc. TGX -C- 33.50 meters GUATEMALA CITY, C. A.	6840 kc. CFA -C- 43.80 meters DRUMMONDVILLE, CANADA
12800 kc. IAC -C- 23.45 meters PIZA, ITALY Mornings	10770 kc. GBP -C- 27.85 meters RUGBY, ENGLAND	9675 kc. *T14NRH -B- 31 meters HEREDIA, COSTA RICA 7-8 p. m.	8920 kc. GCX -X- 33.63 meters RUGBY, ENGLAND	6795 kc. GDB -C- 44.15 meters RUGBY, ENGLAND
12780 kc. GBC -C- 23.47 meters RUGBY, ENGLAND	10675 WNB -C- 28.1 meters LAWRENCEVILLE, N. J.	9600 kc. *CT1AA -B- 31.25 meters LISBON, PORTUGAL Tues. and Friday, 4:30-7:00 p. m.	8760 kc. GCQ -C- 34.25 meters RUGBY, ENGLAND	6753 kc. WOA -C- 44.40 meters LAWRENCEVILLE, N. J.
12290 kc. GBU -C- 24.41 meters RUGBY, ENGLAND	10550 kc. WOK -C- 28.44 meters LAWRENCEVILLE, N. J.	9600 kc. YV2AM -B- 31.25 meters MARACAIBO, VENEZUELA Tests between 5 and 10 p. m.	8680 kc. GBC -C- 34.56 meters RUGBY, ENGLAND	6668 kc. HC2RL -B- 45.00 meters Sunday, 5:45-7:45 p. m. Tues., 9:15-11:15 p. m.
12260 kc. FTN -C- 24.47 meters ST. ASSISE (Paris), FRANCE	10530 kc. GBX -X- 28.49 meters RUGBY, ENGLAND	9600 kc. *XETE -B- 31.25 meters MEXICO CITY, MEXICO 2:30-5:10 p. m., 5-9 p. m., 12 midnight	8560 kc. WOO -C- 35.05 meters OCEAN GATE, N. J.	6660 kc. F8KR -B- 45.00 meters CONSTANTINE, ALGERIA
12150 kc. GBS C-C 24.69 meters RUGBY, ENGLAND	10520 kc. VLK -C- 28.51 meters SYDNEY, AUSTRALIA	9595 kc. *HBL -B- 31.27 meters LEAGUE OF NATIONS GENEVA, SWITZERLAND Saturdays, 5:30-15 p. m.	8560 kc. WOY -C- 35.05 meters LAWRENCEVILLE, N. J.	6650 kc. IAC -C- 45.1 meters PIZA, ITALY Evenings
12000 kc. RNE -B- 25 meters MOSCOW, U. S. S. R. Sunday, 3-4 p. m., and tests irregularly at other times	10410 kc. PDK -C- 28.80 meters KOOTWIJK, HOLLAND 7:30-9:40 a. m.	9590 kc. *W3XAU -B- 31.28 meters NEWTOWN SQUARE, PA. Relays WCAU 12 noon-6 p. m.	8380 kc. IAC -C- 35.8 meters PIZA, ITALY	6610 kc. RW72 -B- 45.38 meters MOSCOW, U. S. S. R. 1-6 p. m.
11950 kc. KKQ -X- 25.10 meters BOLINAS, CALIF.	10410 kc. KES -X- 28.80 meters BOLINAS, CALIF.	9590 kc. *VK2ME -B- 31.28 meters AMALGAMATED WIRELESS, LTD., SYDNEY, AUSTRALIA Sunday, 1-3 a. m., 5-9 a. m., 9-11 a. m.	8185 kc. *PSK -C- 36.65 meters RIO DE JANEIRO, BRAZIL 6:30-7:30 p. m.	6447 kc. HJ1ABB -B- 46.50 meters BARRANQUILLA, COL. S. A. 11:30 a. m.-1 p. m. and 5-10 p. m. daily Thurs., 5-11 p. m.
11880 kc. *FYA -B- 25.25 meters "RADIO COLONIAL" PONTOISE, PARIS	10350 kc. LSX -X- 28.98 meters BUENOS AIRES, ARGENTINA	9585 kc. *GSC -B- 31.29 meters BRITISH BROAD. CAST. DAVENTRY, ENGLAND British Empire programs	8036 kc. *CNR -B- 37.33 meters RABAT, MOROCCO Sunday, 3-5 p. m.	6425 kc. *W3XL -X- 46.70 meters NATIONAL BROADCASTING CO. BOUND BROOK, N. J. Fri., 5:30 p. m.-1 a. m.
11870 kc. *W8XK -B- 25.26 meters WESTINGHOUSE ELECTRIC CO. SAXONBURG, PA. 4:30-10:00 p. m. Relays KDKA programs			7920 kc. GCP -C- 37.88 meters RUGBY, ENGLAND	6382 kc. HC1DR -B- 47.00 meters QUITO, ECUADOR 8-10 p. m.

6335 kc. VE9AP -B- 47.35 meters DRUMMONDVILLE, CANADA	6110 kc. VE9HX -B- 49.10 meters HALIFAX, NOVA SCOTIA 9:30 a. m.-1 p. m.; 6-12 p. m.	6072 kc. OER2 -X- 49.41 meters VIENNA, AUSTRIA Tues. and Thurs., 8:30 a. m.-4 p. m.	6010 kc. COC -B- 49.92 meters HAVANA, CUBA 4-5 p. m.	5145 kc. OK1MPT -X- 58.31 meters PRAGUE, CZECHOSLOVAKIA
6316 kc. HIZ -B- 47.5 meters SANTO DOMINGO, DOMINICAN REPUBLIC Daily except Sat. and Sun. 4:40-5:40 p. m.; Sat., 9:40-11:40 p. m.; Sun., 11:40 a. m.-1:40 p. m.	6110 kc. VUC -B- 49.1 meters CALCUTTA, INDIA Daily except Sat., 9:30 a. m.-noon; Sat., 11:45 a. m.-3 p. m.	6070 kc. YV2AM -B- 49.42 meters MARACAIBO, VENEZUELA Tests between 5 and 10 p. m.	6005 kc. VE9DR -B- 49.96 meters CANADIAN MARCONI CO. DRUMMONDVILLE, QUEBEC 7 a. m.-11 p. m., daily, exc. Sun.; 11 a. m.-10 p. m., Sun.	5077 kc. WCN -C- 59.08 meters LAWRENCEVILLE, N. J.
6272 kc. HI1A -B- 47.8 meters DOMINICAN REP. Daily 12:10-2:10 p. m.; 4:10-6:10 p. m.; Thurs., 12:10-2:10 p. m.; 7:40-9:40 p. m.	6100 kc. *W3XAL -B- 49.18 meters NATIONAL BROADCASTING CO. BOUND BROOK, N. J. Relays WJZ programs Saturday, 5:30 p. m.-1 a. m.	6070 kc. VE9CS -B- 49.42 meters VANCOUVER, B. C., CANADA Fri., 12:30-1:45 a. m.; Sun., 12 noon-12 midnight	6005 kc. VE9DN -B- 49.96 meters DRUMMONDVILLE, QUEBEC Sat., 11:30 p. m.	5025 kc. ZFA -C- 59.7 meters HAMILTON, BERMUDE
6270 kc. HJ3ABF -B- 47.81 meters BOGOTA, COLOMBIA 7-11 p. m.	6100 kc. *W9XF -B- 49.18 meters DOWNERS GROVE, ILL. Relays WENR, Chicago Daily except Sat., 4:30-8:00 p. m. 9:30 p. m.-2 a. m. Sun. 4:30-7 p. m.; 9 p. m.-2 a. m.	6060 kc. *W8XAL -B- 49.50 meters CROSLY RADIO CORP. CINCINNATI, OHIO Relays WLW	6000 kc. EAJ25 -B- 50 meters BARCELONA RADIO CLUB, BARCELONA, SPAIN 3:30-4:30 p. m., Saturday	4975 kc. GBC -C- 60.30 meters RUGBY, ENGLAND
6150 kc. YV3BC -B- 48.78 meters CARACAS, VENEZUELA Generally 4:00-10:00 p. m.	6095 kc. *VE9GW -B- 49.22 meters BOWMANVILLE, ONTARIO, CANADA Mon., Thurs., 3 p. m.-midnight; Fri., Sat., 8 a. m.-midnight; Sun., 12 noon-9 p. m.	6060 kc. VQ7LO -B- 49.50 meters IMPERIAL AND INTERNATIONAL COMMUNICATIONS, Ltd. NAIROBI, KENYA, AFRICA Mon., Wed., Fri., 5:45-6:15 a. m., 11 a. m.-2 p. m. Tues., 3-4 a. m., 11 a. m.-2 p. m., Thurs. 8-9 a. m., 11 a. m.-2 p. m., Sat., 11 a. m.-3 p. m., Sun., 10:50 a. m.-2 p. m.	6000 kc. RW59 -B- 50 meters MOSCOW, U. S. S. R. 4-6 p. m., daily	4820 kc. GDW -C- 62.24 meters RUGBY, ENGLAND
6140 kc. *W8XK -B- 48.86 meters WESTINGHOUSE ELECTRIC & MFG. CO. SAXONBURG, PA. Relays KDKA programs, 4:30 p. m.-midnight	6090 kc. VE9BJ -B- 49.26 meters SAINT JOHN, N. B., CAN. 7-8:30 p. m.	6060 kc. *W3XAU -B- 49.50 meters NEWTOWN SQUARE, PA. Relays WCAU, Philadelphia 8 p. m.-1 a. m. irregular	5970 kc. *HVJ -B- 50.26 meters VATICAN CITY (ROME) 2-2:15 p. m., daily. Sun., 5-5:30 a. m.	4820 kc. G6RX -X- 62.24 meters RUGBY, ENGLAND Tests irregularly 8-11 p. m.
6130 kc. ZGE -B- 49.1 meters KUALA LUMPUR, FED. MALAY STATES Tue. and Fri., 6:40-8:40 a. m. Sun., 7-9 a. m.	6085 kc. CP5 -B- 49.3 meters LAPAZ, BOLIVIA 6:30-7:30 p. m.; 9-11:30 p. m. Mon., Wed., Fri., 6:30-8 p. m. 9-11:30 p. m., Tues., Thurs., Sat.	6050 kc. *GSA -B- 49.58 meters BRITISH BROAD. CORP. DAVENTRY, ENGLAND British Empire programs	5952 kc. HIX -B- 50.4 meters SANTO DOMINGO, DOMINICAN REPUBLIC Tues. and Fri., 8-10 p. m.; Sun., 7:45-10:40 a. m., 3-5 p. m. Sat., 10:40-11:40 p. m.	4752 kc. WOO -C- 63.1 meters OCEAN GATE, N. J.
6122 kc. ZTJ -B- 49 meters JOHANNESBURG, SOUTH AFRICA Daily except Sat. and Sun., 11:45 p. m.-12:30 a. m., 47 a. m., 9 a. m.-3:30 p. m. Sat., only, 4-7 a. m., 9 a. m.-4:45 p. m. Sun., only, 11:45 p. m.-12:30 a. m., 8-10:30 a. m. and 12:30-3 p. m.	6080 kc. *W9XAA -B- 49.31 meters CHICAGO FEDERATION OF LABOR CHICAGO, ILL. Relays WCFL	6040 kc. W1XAL -B- 49.67 meters BOSTON, MASS.	5930 kc. HJ4ABE -B- 50.6 meters MEDELLIN, COLOMBIA Mon., 7-11 p. m.; Tues., Thurs., Sat., 6:30-8:00 p. m.; Wed. and Fri., 7:30-11:00 p. m.	4752 kc. WOY -C- 63.1 meters LAWRENCEVILLE, N. J.
6120 kc. *W2XE -B- 49.02 meters ATLANTIC BROADCASTING CORP., WAYNE, N. J. 6:00-11:00 p. m.	6075 kc. OXY -B- 49.4 meters SKAMLEBOAER, DENMARK Irregular, 1-6 p. m.	6040 kc. W4XB -B- 49.67 meters MIAMI, FLORIDA Relays WIOD, evenings	5853 kc. WOB -C- 50.25 meters LAWRENCEVILLE, N. J.	4320 kc. GDB -C- 69.44 meters RUGBY, ENGLAND
6120 kc. *YV1BC -B- 49.02 meters CARACAS, VENEZUELA 10:30 a. m.-1 p. m.; 5:15-10 p. m.	6075 kc. PK1WK -B- 49.4 meters BANDOENG, JAVA Daily exc. Fri., 5:30-6 a. m.	6030 kc. VE9CA -B- 49.75 meters CALGARY, ALTA, CANADA	5690 kc. FIQA -B- 52.7 meters ADMINISTRATION DES P. T. T. TANANARIVE, MADAGASCAR Tues., Wed., Thurs., Fri., 9:30-11:30 a. m., Sat. and Sun., 1-3 p. m.	4320 kc. *G6RX -X- 69.44 meters RUGBY, ENGLAND Tests, 8-11 p. m.
		6023 kc. XEW -C- 49.8 meters MEXICO CITY, MEXICO	5170 kc. PMY -C- 58.00 meters BANDOENG, JAVA	4273 kc. *RW15 -B- 70.20 meters KHABAROVSK, SIBERIA, U. S. S. R. Daily, 3-9 a. m.
		6020 kc. *DJC -B- 49.83 meters ZEESEN, GERMANY	5714 kc. HCK -B- 52.5 meters QUITO, ECUADOR, S. A.	4272 kc. WOO -C- 70.22 meters OCEAN GATE, N. J.
				4272 kc. WOY -C- 70.22 meters LAWRENCEVILLE, N. J.
				4098 kc. WND -C- 73.21 meters HIALEAH, FLORIDA
				4000 kc. HCJB -B- 73 meters QUITO, ECUADOR 7:30-9:45 p. m., except Monday

A Word of Explanation About S. W. Schedules

This list is compiled from many sources, all of which are not in agreement. In fact, conflicting data are received sometimes from the stations themselves. We are constantly writing to stations all over the world and reading reports from hundreds of correspondents. We invite individual listeners to inform us of any stations not listed herewith, or operating on frequencies or hours different from those indicated. All times given are Eastern Standard.

Listeners living in zones operating on daylight saving time must make their own corrections.

Special Note: Please do not ask us to identify unknown stations from snatches of voice or music. This is utterly impossible. Make a notation of the dial setting and try for the station again until you get an understandable announcement. This list will appear again with last minute corrections, in the June issue.

WHEN TO LISTEN IN

LSX Has Regular Schedule
A letter just received from LR4, "Radio Splendid," Buenos Aires, states that they will begin a daily short wave relay of their programs on LSX, 10,350 kc., on Feb. 1st for the benefit of foreign listeners. The programs will consist of Argentine music and news. Programs for Europe will be

broadcast daily from 3-4 p.m. (E.S.T.) and for North America from 8-9 p.m. daily (E.S.T.). LSX is a very well received station in this country, so many enjoyable programs should be heard. All letters will be acknowledged. LR4 is one of the largest stations in the Southern Hemisphere. It operates on 990 kc. (same as WRZ, Boston) with a power of 20 kw. LSX is rated at 12

kw. The address is Radio Splendid, Callao 1526, Buenos Aires.

The German Stations

The latest information on the German stations at Zeesen is as follows: DJB, 15,200 kc. 7:15-11 a.m. daily, and DJC, 6,020 kc. and DJD, 11,760 kc., 8-11 p.m. daily.

SHORT WAVE QUESTION BOX

SIZE R.F. CHOKE

James B. Watson, Bangor, Me.

(Q) Will you please inform me as to the value of the three radio frequency chokes used in the set described on pages 18 and 19 of the May issue of SHORT WAVE CRAFT?

(A) The size of the three radio frequency chokes used in the "3-tube DX'er" should be from 2½ to 5 millihenries.

RECEIVER AND TRANSMITTER DIAGRAMS

W. L. Shelton, Fredericksburg, Va.

(Q) Please print diagrams of short-wave receivers and transmitters.

(A) Within the past six months we have published a great many circuits of transmitting and receiving short-wave apparatus. We suggest that you consult some of these issues and we feel sure you will find something to suit your needs.

3-TUBE SHORT WAVE RECEIVER HOOK-UP

Joseph Faria, Oakland, Calif.

(Q) Will you please publish a diagram for a 3-tube short-wave receiver using a 57 detector, 27 first audio and 47 output amplifier.

(A) On this page you will find the diagram requested, together with the values of each part.

ELIMINATING IMAGE RESPONSE

John Morrison, Kansas City, Mo.

(Q) I have a factory made short-wave converter attached to my Atwater Kent receiver. I am bothered with a good deal of image interference. One station in particular does most of the damage and they are located about four blocks away. Would a shielded lead-in wire help in this case?

(A) We do not believe that you are experiencing image interference. There is either one of two things that can be happening—that is, you are either picking up harmonics of this station or your receiver is not selective enough to eliminate the interference caused by modulation in the broadcast station. We believe if you add a pre-selector to your present receiver or install a wave trap which should be tuned to the frequency of the broadcast station you would easily overcome your trouble.

S.W. RECEIVER USING 01A TUBES

James Landon, Los Angeles, Calif.

(Q) I am trying to get an amateur station started and would like to have you publish a diagram of a set using three 01A tubes.

(A) On this page you will find a diagram of a short-wave receiver using an 01A regenerative detector and two stages of audio using the same type tubes.

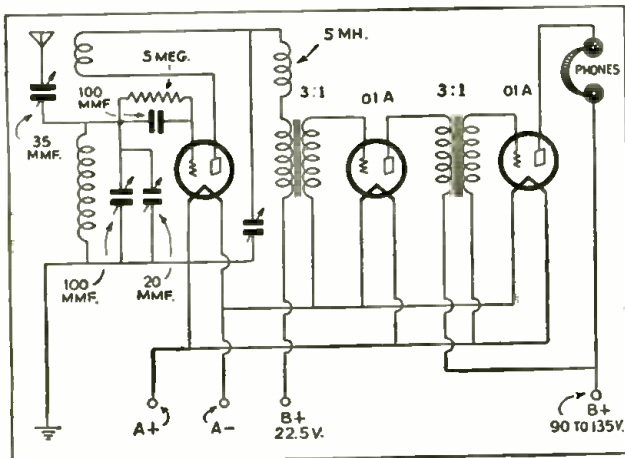

3-Tube battery set using 01A tubes.

EDITED BY

GEORGE W. SHUART, W2AMN

● Because of the amount of work involved in the drawing of diagrams and the compilation of data, we are forced to charge 25c each for letters that are answered directly through the mail. This fee includes only hand-drawn schematic drawings. We cannot furnish "picture-layouts" or "full-sized" working drawings. Letters not accompanied by 25c will be answered in turn on this page. The 25c remittance may be made in the form of stamps or coin.

Special problems involving considerable research will be quoted upon request. We cannot offer opinions as to the relative merits of commercial instruments.

Correspondents are requested to write or print their names and addresses clearly. Hundreds of letters remain unanswered because of incomplete or illegible addresses.

CHARGING BATTERY FROM 110 VOLT D.C.

Nels I. Rolfson, Hill City, S. D.

(Q) Can a 110 volt D.C. plant be used to charge a 6 volt storage battery? What would be the necessary apparatus and how

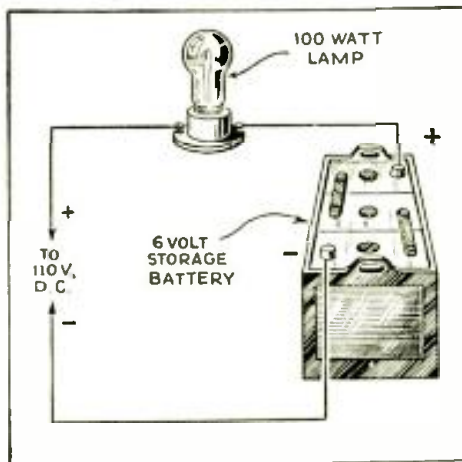

Battery charging circuit for 110 volt D.C. mains.

could the polarity of the line be determined?

(A) A diagram showing the connections for charging a 6 volt battery from a D.C. plant is shown on this page. To determine the polarity of the line submerge the two wires into a glass of salt water. Hydrogen bubbles will be found to be greater on the negative wire.

BROADCAST TRANSMITTER

Francis L. McCray, Elgin, Pa.

(Q) Would it be possible to use a Neutrodyne 5-tube battery type receiver converted over into a broadcast transmitter for a low power broadcast transmitting station?

(A) It is impossible for you to use this type of transmitter in broadcast work. High class equipment is necessary and required by the Federal Radio Commission for a broadcasting station. We suggest that you get in touch with the Federal Radio Commission and request their booklet governing broadcast stations.

MAN-MADE STATIC

R. J. Symonds, Fairfield, Ia.

(Q) My neighbors and I are bothered by a buzzing type of noise in our radio receivers. This noise is found in both short and long wave receivers. Usually the buzzing sound lasts for ten or fifteen seconds and then there is an interval where there is no interference and then the buzzing continues again. This interference practically ruins radio reception in our vicinity.

(A) The noises you mention are usually caused by electric refrigerators, or some other electrical machinery that is operating intermittently. The only thing you can do is to try to locate definitely where this noise is originating and inform the owner of the property to make provisions for eliminating this interference. A portable receiver is usually used in tracing down these noises.

DEAD SPOTS IN RECEIVERS

Edward Klingsporn, North Bergen, N. J.

(Q) I have built the 2-Tube Doerle receiver and have only received one distant station, DJC, Germany, on 31.38 meters. The 60 to 120 meter coils work fine but the two high frequency coils do not function properly and I do not get stations all over the dial. How can this be remedied?

(A) It is quite likely that you are experiencing dead spots caused by absorption due to the antenna. This is usually overcome by loosening the coupling of the antenna by reducing the capacity of the antenna coupling condenser.

REMODELING CONDENSERS

Tony Debeve, Madison, Ohio.

(Q) How can I reduce the capacity of .00035 mf. variable condenser to a value suitable for short-wave work?

(A) In order to reduce .00035 mf. condenser to a value that will be suitable for tuning short-wave receivers, we suggest that you remove half the number of plates without altering the spacing between the plates. This will result in a capacity of approximately .00017 mf.

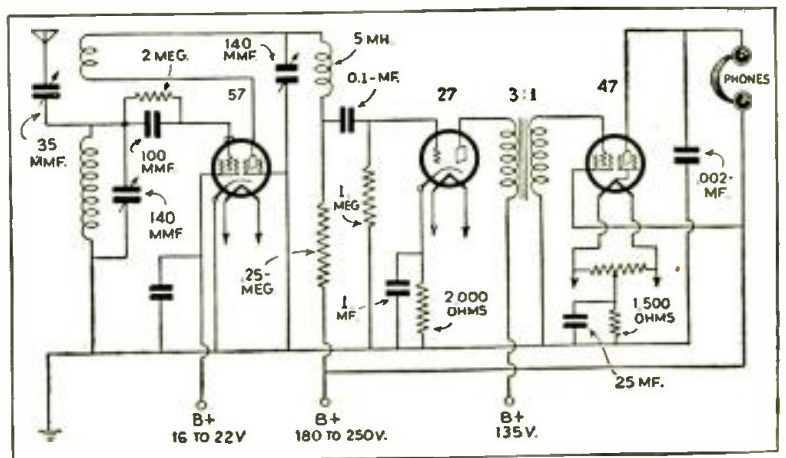

S.W. receiver using A.C. tubes.

Crystal Control for the Lean Purse

(Continued from page 731)

so that one side will not be ground down faster than the other.

A check should be made from time to time during this rough grinding process—using the micrometer to test the parallelism of the crystal blank. Should one side or portion of the crystal become thicker through uneven grinding this should be taken care of immediately by applying pressure on the thick spot until the grinding side is again parallel to the reference side. Care must be taken throughout the grinding process to keep the two plane surfaces as parallel as possible.

When you have ground the blank to within five thousandths of an inch of your desired thickness it is time to begin the use of the FFF abrasive for finishing. The final operations are exactly the same as the rough grinding although more care and close attention should be exercised to keep the surfaces parallel. It is not necessary to obtain a high polished finish on the crystal. A smooth frosted surface apparently oscillates just as well as the glossy or shiny finish. In an 80 meter crystal the error of tolerance should not exceed five ten thousandths (.0005) of an inch.

Finishing the Crystal

You now have a crystal with both sides as nearly parallel as possible and there remains but one more operation before the blank becomes a finished product. To properly finish the crystal, its edges should be ground smooth and slightly beveled. This is accomplished by grinding the edges on a carborundum stone with the aid of water. Care should be taken to edge-grind the crystal until all the nicks, scratches and rough spots have been removed. With the edge free from all imperfections the crystal is now finished and will oscillate somewhere near the frequency that you desire. Careful grinding on the plane grinding side and a frequent check on parallelism, frequency and ease of oscillation will soon bring the crystal to the required frequency.

If Crystal Refuses to Oscillate

If you have a Curie blank that refuses to oscillate readily at the required thickness—even though the surfaces are parallel—a condition of easy oscillation can be produced by further edge-grinding. If in the case of the parallel cut you find two points of oscillation within a few thousand cycles of each other, this can be eliminated by carefully examining the blank for thick spots. Bringing the blank into parallelism by very light grinding will overcome this condition.

Abuse of the crystal by using excessive plate voltage on the crystal oscillator tube is unnecessary and will result in the faulty operation of the crystal and its attendant circuits. This means overheating of the crystal, a wide frequency drift and the probable puncture and consequent ruination of the crystal, *four hundred volts is sufficient and more should never be used!* The accepted practice in amateur work is to secure grid bias by the use of a resistor across the two plates of the crystal holder.

Now to continue with the transmitter proper.

Tuning

A valuable aid to tuning any transmitter consists of two or three turns of wire shunted around a low current flashlight lamp although a small neon lamp may be used to advantage also.

After the wiring has been checked, the tubes are inserted into their respective sockets and the filament voltage applied next, the bias is connected to the amplifiers

Pretzel Bender!



THE TOAST OF THE TOWN!

Otherwise known as Unshielded "2"

Rarely does it happen in the ordinary course of events that success comes over night. Seldom does it come about that spontaneous applause is given to a new radio receiver. Yet, thousands of Short Wave Fans everywhere have hailed the advent of the Pretzel Bender,* the Unshielded "2," for they recognized that here was something new in S.W. Receivers at a price so low that it was almost unbelievable.

A Set for Beginners

The Pretzel Bender has been designed especially for the S.W. Novice although it will satisfy the most discriminate S.W. fan. It features high r.f. sensitivity, simplified circuit and design, smooth regeneration control, ease of tuning, use of low-current drain 2 volt tubes, specially designed short wave coils, antenna tuning control, all-pentode operation, unusually thorough by-passing, newly developed self-shielded chassis design of high efficiency and low cost.

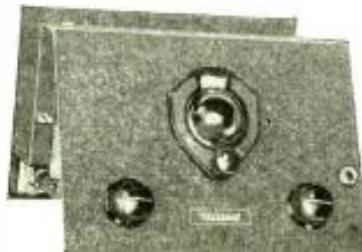

UNIQUE DESIGN

The chassis panel, and shielding are in one piece, as shown in the photographs. This results in a sloping panel of pleasing appearance, a "U" shaped shielded well for the tubes and plug-in coil as well as effective shielding for the parts beneath the chassis. This design eliminates extra shielding. No wonder it is compact, rugged and economical.

EASY TO OPERATE

The Pretzel Bender comes in two models—a 2-tube and 3-tube receiver. The power of both models is remarkable. One need not be experienced nor employ "tricks" to bring in foreign stations. The "Three" of course, brings in hard-to-get stations more easily because of its greater power. London, Paris, Berlin, Caracas, Melbourne, Singapore, Tokio, Moscow—are a few of the stations that you can get.

The Pretzel Bender comes in kit form for those who wish to build their own set or may be obtained completely wired at a slight additional cost. It's the most Short Wave value for your money in all of Radio today. For prices see coupon attached.

MAIL THE COUPON TODAY

* The Pretzel Bender was conceived in the experimental laboratory and because of its peculiar self-shielding construction, it was called the Uni-Shielded Three. However, the name was cumbersome so some wit, noting its odd shape nick-named it the Pretzel Bender.

And Pretzel Bender it still is to the thousands who have already pleasantly learned that really thrilling Short Wave reception need not be a costly adventure.

Wholesale Radio Service Company
100 Sixth Ave. Dept. SW-44
New York, New York

I enclose \$..... for the following order on

The Pretzel Bender	TWO	THREE
Complete kit, less tubes and coils	<input type="checkbox"/> at \$5.75	<input type="checkbox"/> at \$7.45
Set of tubes.....	<input type="checkbox"/> at 1.93	<input type="checkbox"/> at 2.90
Set of 1 coils.....	<input type="checkbox"/> at 1.35	<input type="checkbox"/> at 1.35
If wanted wired, add.....	<input type="checkbox"/> 2.50	<input type="checkbox"/> 2.75

Name

Address

City..... State.....

WHOLESALE RADIO SERVICE CO. INC.
100 Sixth Avenue, New York, N.Y.
New Branch
219 Central Avenue, Newark, N.J.



FREE

1934 Official Short Wave Radio Manual
1934 Official Radio Service Manual



FREE WITH ARCO TUBE PURCHASES, you may select a 1934 OFFICIAL SHORT WAVE RADIO MANUAL which sells for \$2.50, with your order amounting to \$8.00

If you prefer you can get FREE, the 1934 OFFICIAL RADIO SERVICE MANUAL which sells for \$3.50 with orders amounting to \$10.00 or both manuals for orders of \$17.00.

THIS OFFER IS SUBJECT TO WITHDRAWAL WITHOUT NOTICE.

Complete Stock Ready for Immediate Shipment

Order from this page—Remit 20% with order, balance C. O. D. All prices are F. O. B. FACTORY, Newark. Shipments go forward express or Parcel post. No order for less than \$3.00 accepted.

Type No.	Fil. Voltage	Your Cost	Type No.	Fil. Voltage	Your Cost
00A	5.0	.40	82	2.5	.85
01A	5.0	.30	83	5.0	.85
1	6.3	.85	84	6.3	.85
10	7.5	1.10	85	6.3	.60
12A	5.0	.40	89	6.3	.60
20	3.3	.40	X199	3.3	.40
22	3.3	.85	V199	3.3	.40
24A	2.5	.40	2A3	2.5	1.10
26	1.5	.39	2A5	2.5	.85
27	2.5	.30	2A6	2.5	.85
30	2.0	.60	2A7	2.5	1.10
31	2.0	.60	2B6	2.5	1.10
32	2.0	.60	2B7	2.5	1.10
33	2.0	.85	5Z3	5.0	.85
34	2.0	.85	6A4	6.3	1.10
35	2.5	.60	6A7	6.3	1.10
36	6.3	.60	6B7	6.3	1.10
37	6.3	.60	6C6	6.3	.85
38	6.3	.60	6C7	6.3	.85
39	6.3	.60	6D6	6.3	.85
40	5.0	.40	6D7	6.3	.85
41	6.3	.60	6E7	6.3	.85
42	6.3	.60	6F7	6.3	.85
43	25.0	.85	6Y5	6.3	.85
44	6.3	.60	6Z3	6.3	.85
45	2.5	.40	6Z4	6.3	.85
46	2.5	.60	6Z5	6.3	.85
47	2.5	.60	12A5	6.3	.85
48	30.0	1.10	12Z5	6.3	.85
49	2.0	.85	25Z5	25.0	.85
50	7.5	1.10	12Z3	12.6	.85
51	2.5	.60	182B	5.0	.85
53	2.5	.85	183	5.0	.85
55	2.5	.60	401	3.0	1.50
56	2.5	.60	403	3.0	2.00
57	2.5	.60	484	3.0	.85
58	2.5	.60	485	5.0	.85
59	2.5	.60	586	7.5	2.10
71A	5.0	.30	686	3.0	.85
75	6.3	.85	866	2.5	2.75
77	6.3	.85	PZH	2.5	.85
78	6.3	.85	WD11	1.1	.60
79	6.3	1.10	WD12	1.1	.60
80	5.0	.40	216B	7.5	.85
81	7.5	1.10	213	5.0	.60

RECTIFIER AND CHARGER BULBS

- 125 Mil. rectifier tube B.H. (Raytheon type).....\$1.25
- 6-10 Amp. trickle charger Bulb (Tunstar type)..... 2.00
- 2 Amp. charger Bulb (Tunstar type)..... 2.00
- 5 and 6 Amp. charger Bulb (Tunstar type)..... 3.75
- 15 Amp. charger Bulb (Tunstar type)..... 7.50
- UX-280M—5.0 Full Wave Mercury Vapor Rectifier..... 1.10
- VX-281M—7.5 Half Wave Mercury Vapor Rectifier..... 1.90
- UX-871 —2.5 Half Wave Mercury Vapor Rectifier..... 1.10
- UX-872 —7500 Volts Half Wave Merc. Vap. Rec.....11.00

TELEVISION TUBES and PHOTO ELECTRIC CELLS

- Photo Cell, "Potassium", 3 1/2" overall length, Type C.....\$2.10
- Photo Cell, "Caesium", 4 1/2" overall length, Type A 7.90
- Photo Cell, "Caesium", 3-1/16 overall length, Type B..... 5.90
- Photo Cell, "Caesium", Type T, same as UX-868, 5.90
- Reflectron Neon Television Tube, 2" Cathode Square, Type C..... 2.85
- Neon Television Tube, 1 1/2" Cathode Square, Type V..... 3.85
- Neon Television Tube, 1" Cathode Square, Type X..... 2.85

ARCO TUBE COMPANY
40 Park Place Newark, N. J.

and the plate voltage to the crystal stage only is turned on. With the resonance indicator coupled loosely the crystal tuning condenser is varied until maximum power is observed by the indicator. With plate voltage on both oscillator and buffer stage and indicator coupled to buffer tank circuit, rotate tank condenser for maximum output. It will be noticed that for maximum output the space current of the amplifier will be at a minimum and fall off on either side.

If one desires to operate both amplifiers on the same frequency as the crystal, it is necessary that each one of them be neutralized, otherwise self oscillation will result, which is to be avoided. As this set has been primarily intended for operation in the 40 and 20 meter bands, it will only be necessary to neutralize the last stage; however, for 80 meter work both buffer and amplifier should be treated in this manner.

With the oscillator and buffer operating, but without any plate voltage on the last

stage, the resonance indicator is coupled to the tank coil of the amplifier. The amplifier condenser is turned until resonance is indicated by the indicator. Then the neutralizing condenser is varied until the lamp of the pickup coil is extinguished. It may be necessary to change the position of the positive plate supply feeder's position on the tank coil to accomplish this. When the amplifier has been completely neutralized the tank condenser may be rotated over its entire scale without relighting the indicator-lamp.

Connect up the amplifier plate voltage and with the R.F. indicator coupled to the last stage, retune each circuit until maximum output is obtained.

No antenna has been described as this is something that will vary with individual locations, the one used by the writer was a half wave loop.

The results, you may be assured, are all that may be desired.

A. C. Monitor for "Hams"

(Continued from page 735)

achieved by making the set operative from the A.C. line. During the course of the experimental work, many arrangements were tried, but a simple transformer-less circuit was finally evolved as the most suitable. Perhaps at some future date a story will be written on the more elaborate jobs, but the three-tube monitor pictured is a very excellent piece of equipment and will give really good results.

Circuit of the Monitor

Three type 37, 6-volt heater tubes are used in the set. One is used as a detector, another as an audio amplifier, and the third is used as a half-wave rectifier. The tubes are placed in the order named from left to right along the rear edge of the

chassis. The plug-in coil is mounted in the front left-hand edge of the chassis. The central dial on the panel is the tuning control. The plug-in phone jack and the on-off switch are likewise mounted on the panel.

Extreme care should be taken to make sure that the phone jack is carefully insulated from the panel. The filter chokes are eliminated by two small 5,000 ohm resistors, which work just as well as chokes on small current drains. A series resistor is used to drop the voltage for the filaments of the tubes. This is mounted on the back of the chassis, in the air, as it dissipates a large amount of heat. The filter condensers, which are of the 200 volt electro-

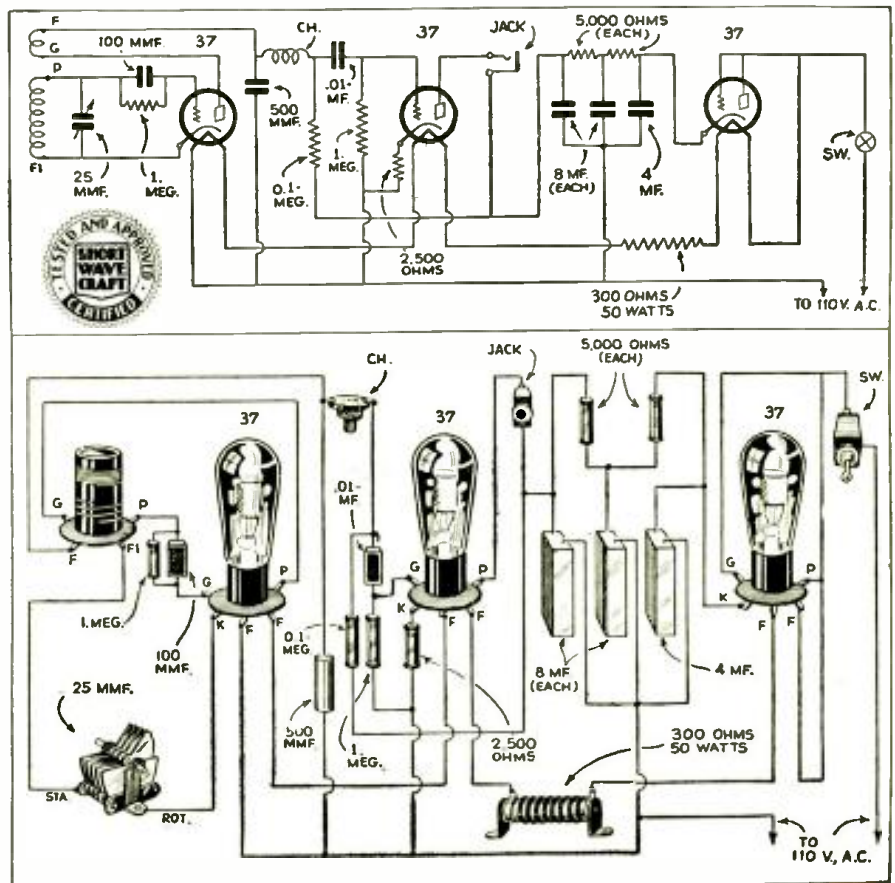

Picture and schematic diagrams of the A.C. Monitor.

lytic type, are taped together and mounted in the front right-hand portion of the chassis. It is not necessary to build the set on a sub-panel, it might very well be made bread-board fashion, but care should be taken to see that it is totally shielded.

COILS

The coils are wound on tube-bases, with number 30 d.c.c. wire.

Band		1.1	1.2
1750 Kc.	60	12
3500 Kc.	35	6
7000 Kc.	14	5
14000 Kc.	6	3

As with all sets a certain amount of cut and try will be necessary. The number of coil turns will probably not be the same on all monitors. However, in most cases the difference will only be a matter of 1 or 2 turns. Another thing that may crop up is too loud a signal. This can be remedied by varying the capacity of the .002 mf. plate blocking condenser. Likewise a little experimentation with the 100,000 ohm plate-resistor, such as changing it for 150,000 or 75,000 ohms, may bring better results in individual cases. Then try all three tubes as detector. One of the three may prove much more stable, that is, will show less drift when heard in the receiver over a period of time. Detailed instructions for "calibration" were given in the October, 1933, issue of this magazine; with their aid it should be a simple matter to make a series of graphs for the various wave-bands. Remember that a lot of the accuracy in a monitor is dependent on the choice of the tuning condenser and the vernier. If an extreme degree of calibration accuracy is desired, there are several makes of dials on the market made expressly for calibration purposes.

Parts List

- 2—1 meg. ½ watt resistor, Lynch (I.R.C.)
- 1—100,000 ohm, ½ watt resistor, Lynch (I.R.C.)
- 1—2,500 ohm, ½ watt resistor, Lynch (I.R.C.)
- 1—300 ohm, 50 watt line resistor
- 2—8 mf. electrolytic condensers, (200 volts)
- 1—4 mf. electrolytic condenser, (200 volts)
- 3—5-prong wafer sockets. Na-ald
- 1—phone jack
- 1—25 mmf. variable condenser, National (Hammarlund)
- 1—shield cabinet
- 1—dial, National
- 1—R.F. choke, 2.5 to 5 mh., National (Hammarlund)
- 3—type 37 tubes, RCA Radiotron (Arco).

Most Powerful "Short Wave" Transmitters

Meters	ABROAD		Location
	Kilo-cycles	Kilo-watts	
70.2	4,273	20	Kharbarovsk, Russia (RV15)
49.59	6,050	20	Daventry, England (GSA)
31.27	9,595	18	Radio Nations, Switzerland (HBL)
25.63	11,705	15	Radio Colonial, Paris (FYA)
25.57	11,730	20	Eindhoven, Holland (PHI)
25	12,000	20	Moscow, Russia (RNE)

Meters	IN UNITED STATES		Location
	Kilo-cycles	Kilo-watts	
48.86	6,140	40	Pittsburgh, Pa. (W8XK)
46.69	6,425	18	Bound Brook, N. J. (W3XL)
31.48	9,530	40	Schenectady, N. Y. (W2XAF)
19.64	15,270	15	Wayne, N. J. (W2XE)

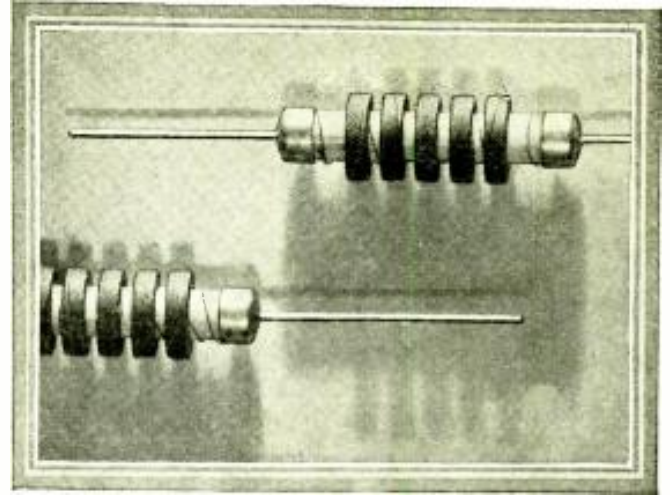

Aristocrats
of the
CHOKE FAMILY

TO THE radio-wise, the Hammarlund imprint on a radio-frequency or transmitter choke coil has the same significance as the Hammarlund name on the world's finest condensers, and custom-built professional receivers. It means "Quality of design, workmanship and performance, insured by more than 33 years of the highest engineering standards."

MIDGET R.F. CHOKES
(Actual Size)

Invaluable for small space. So compact and light, they are amply supported in a circuit by their tinned copper leads. And so inexpensive they may be used generally wherever R.F. filtering is desirable. Five universal-wound pies on Isolantite core. Inductance 2.1 mh. D.C. resistance 35 ohms. Distributed capacity 1 mmf. Length across caps 1½". Diameter ¼". Current 125 milliamperes.

HEAVY-DUTY TRANSMITTING CHOKES

The only high-power choke in which more than 500,000 ohms of impedance is effective at the 20, 40, 80 and 160-meter amateur bands. Six thin universal-wound pies on Isolantite core. Tapped holes for removable mounting brackets. Size 1½" x 2¾". Inductance 2.5 mh. Distributed capacity less than 1.5 mmf. D.C. resistance 8 ohms. Continuous current 500 milliamperes.



(One-Half Actual Size)



HAMMARLUND MANUFACTURING CO.
424 W. 33rd St., New York.
—Check here for new booklet describing the COMET "PRO" Receiver.
—Check here for General Catalog "34" of Chokes and Other Radio Parts.

Name

Address

..... SW-4

A New 2-Tube Short-Wave Converter

(Continued from page 735)

the electric outlet and this cord becomes warm under normal operating conditions, due to the heat that is dissipated by the dropping resistor.

Plug-in coils are not used. A very efficient band switching arrangement has been worked out to give a "coverage" on one position from 20 to 65 meters and on the other 60 to 200 meters. The plate supply for this converter is obtained directly from your broadcast receiver. It is necessary that a wire be attached to some point in the power supply of the broadcast receiver delivering between 180 and 280 volts. Another wire is provided which connects to the

chassis of the broadcast receiver furnishing a negative high-voltage connection. The band-changing switch is so arranged that when the antenna terminal on the broadcast receiver is connected to the converter, and the antenna proper connected to the converter, the antenna is connected back to the broadcast receiver when the converter is turned off. In operating this converter it is necessary to tune the broadcast receiver to some point between 333 to 237 (900 to 1,100 kc.). The two tuned circuits in the converter are designed to track, when using this intermediate frequency.

EVERY SET BUILDER MUST HAVE THIS BOOK

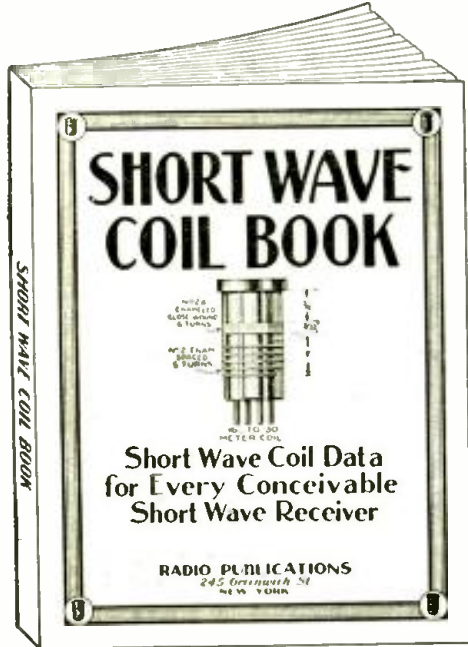

FOR the first time, it is now possible for the experimenter and short wave enthusiast to obtain the most exhaustive data on short wave coil winding information that has ever appeared in print.

As every experimenter who has ever tried to build a short wave set knows only too well by experience, the difference between a good and a poor receiver is usually found in the short wave coils. Very often you have to hunt through copies of magazines, books, etc., to find the information you require. The present data has been gotten up to obviate all these difficulties.

Between the two covers of this book you now find every possible bit of information on coil winding that has appeared in print during the past two years. Only the most modern "dope" has been published here.

No duplication. Illustrations galore, giving not only full instructions how to wind coils, but dimensions, sizes of wire, curves, how to plot them, by means of which any coil for any particular short wave set can be figured in advance, as to number of turns, size of wire, spacing, etc.

There has never been such data published in such easy accessible form as this.

Take advantage of the special offer we are making today, as due to increasing costs, there is no question that the price will increase soon.

RADIO PUBLICATIONS
245 Greenwich Street
NEW YORK, N.Y.



Radio Publications,
245 Greenwich Street,
New York, N. Y.

SW-4-34

Please send immediately, your Short Wave Coil Book, for which I enclose 25c herewith (coin, U. S. stamps or money order acceptable). Book is to be sent prepaid to me.

Name.....

Address.....

City and State.....

How Arthur Ozsvath Relayed "Rescue" Message

(Continued from page 727)

very weak and figuring this wasn't exceptional DX I tuned further hoping to hear a W6 or a W7, which, of course, I didn't. So I tuned back to VE2IC, who was still calling me. If there was the slightest QRM I doubt if I could have pulled him through. When he stood by I gave him his report QSA 4R5 and stood by for mine. He didn't give me one but just said he was on a rescue plane and could I take a wire for Montreal. I was hesitant at first because of the round-about way the message would go: from a VE2 down to New York. However, I accepted the message, seeing it was from a rescue plane. He ended up by asking me to telephone it. Well, it must be important if he wanted it telephoned. A friend of mine, Bob Kapp, came in just at this point so we went to his house to phone it. I was told on the phone that they had been anxiously waiting to hear from the plane, as it had been missing for quiet some time. I later found that it was since December 20th.

After this was all done I "shut down" and counted it as just another message handled.

I later found out more about the situation from the Canadian Airways. A trapper and his wife were flown up into Canada from Montreal by Dick Bibby. They were long overdue, so Lymburner, of the Airways, was sent out to look for them. His plane was equipped with a transmitter and receiver. He located them at Port Harrison, which is about 700 miles North of the lower end of James Bay. They were forced to stay there because of the damage done to the landing gear of the plane when landing on rough snow conditions. When Lymburner found them they were none the worse for their cold stay.

The Canadian Airways have radio stations of their own in Canada. They are all located in the Northwestern part of Canada, however, and therefore the Eastern Lines sometimes have difficulty in keeping schedules. Lymburner, not being able to make contact, switched to the 40 meter "ham" band, which gave him a better chance to contact someone.

When the Canadian Airways received the message they sent out a seven-passenger plane to get the fliers.

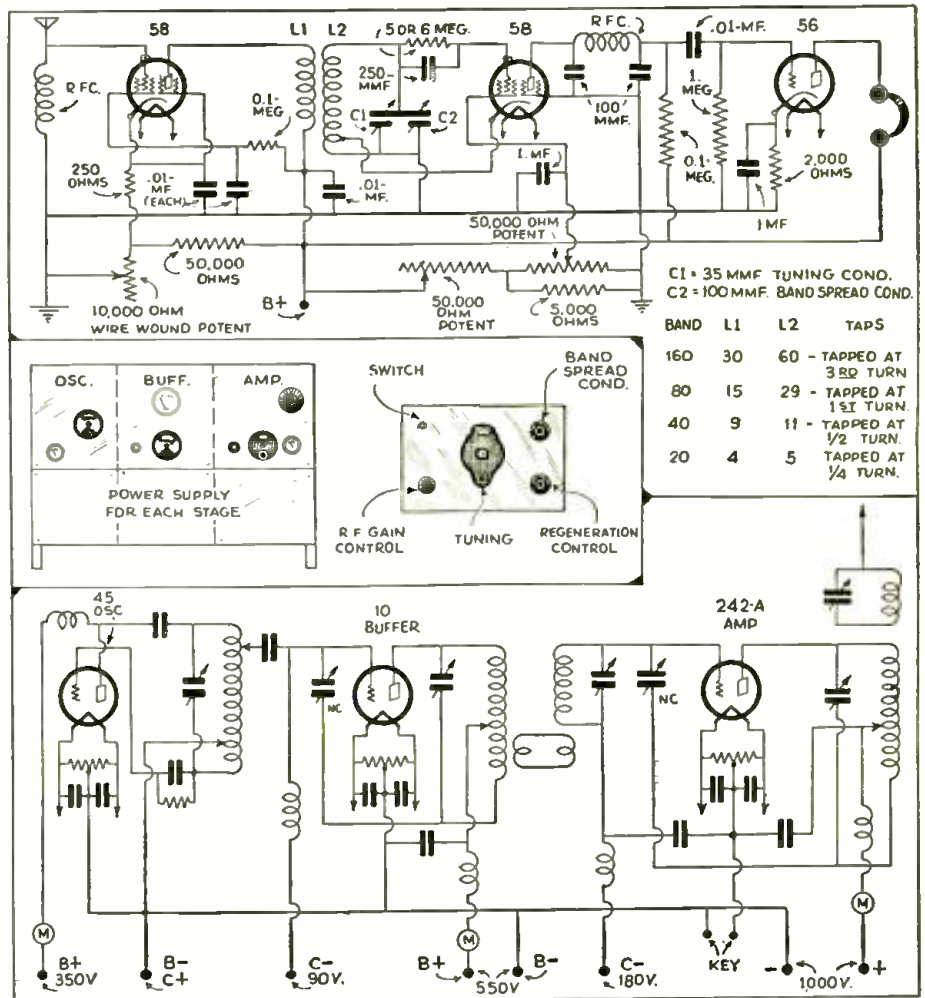

Mr. Ozsvath's station employs receiver (top); panel arrangement (center), and transmitter hook-up as per lower diagram.

W2XE - The Short Wave Voice of C.B.S.

(Continued from page 712)

Canada, Canal Zone, Central America, Cuba, England, Hawaii, Porto Rico, Scotland, Trinidad and the United States.

An unusual feature of the operations of this station is the fact that the station identification announcements are made in English, German, French, Italian and Spanish. These announcements are made in order to facilitate the identification of this station by its foreign audience.

W2XE is located in a corner of the WABC transmitter building at Wayne, N. J., located about 25 miles from New York City. Technically, this short wave equipment is a 1,000 watt, crystal-controlled transmitter, which is capable of 100 per cent modulation. Its construction is such as to permit rapid adjustment to the various frequencies at which it operates.

Unitrol Receiver Simplifies Band Spread

(Continued from page 723)

tube with a 50,000 ohm variable resistor. This control is made much smoother by connecting a fixed resistor as shown in the diagram from one side of the potentiometer to the "B" negative. The antenna is coupled in the usual manner using a small variable condenser connected between it and the grid. This is another sore spot in short-wave receivers and before long some young "Marconi" will present a better method to be used where there is no R.F. stage ahead of the detector.

This makes an ideal receiver for the beginner or a good auxiliary for the fellow who has an A.C. operated rig. Any station that can be received on any other type of receiver can be heard on this little set but, of course, with much less volume. Then again there are many fellows living in locations where lighting mains are not available and they should find this set to meet their needs readily, considering the fact that they can now purchase a 2 volt filament battery that can be recharged and will give years of service.

To construct the special tuning condenser shown in the photographs and drawings it is necessary to obtain one 20 mmf. and one 140 mmf. Hammarlund tuning condensers. These were chosen because they lent themselves readily to the arrangement.

A one-eighth inch hole is drilled through the center of the shaft of the 20 mmf. condenser unit. It is best, if one does not have a drill-press or lathe, to take it to the local machine shop and have it done accurately. After this is done saw a slot in the front of the shaft to fit a piece of number 14 buss bar. A similar slot is cut in the front of the 140 mmf. condenser shaft. These slots are used to lock the two condensers together. Now mount the two condensers on a metal strip as shown in the drawing and we are ready to install the shaft.

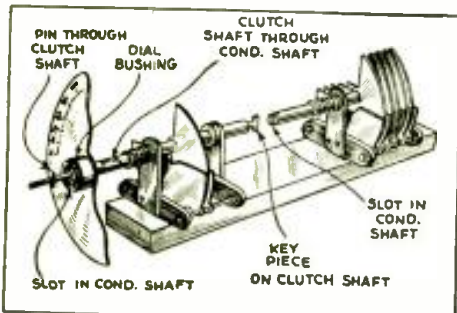

This cut shows clearly the construction of the new band-spread condenser "clutch". When the central shaft is pushed in, the two condensers are engaged together and when it is released the dial turns only a small condenser, allowing full "band-spread" at any frequency in the short-wave spectrum.

Procure a length of brass shafting that will fit snugly in the hole drilled in the shaft of the small condenser. Shape the end of the shaft to fit in the slot cut in the large condenser; if a better job is wanted a pin, as used by the author, can be fitted to the end instead. Now insert the shaft and engage it in the large condenser firmly, so that it can be marked for the front pin. The shaft has two pins, one for the rear and one for the front condenser. Mark the shaft for the pin which engages the small condenser and drill the hole very accurately as there should be no difference in the settings of the two condensers when the shaft is engaged in the two.

Thread the end of the shaft so that a small binding post-knob can be attached for shifting from "regular" tuning to "band-spread".

Tuning with this condenser is very simple: turn the band-spread condenser so that the shaft will lock the two condensers together and proceed to tune as usual. When a section of the range of the condenser is reached where you want band-spread, just pull out the knob in the center of the dial and presto!

V K 2 M E



on the speaker!" writes Donald O'Sullivan of Rutherford, N. J. John F. Coleman, 154 W. 31st St., New York City, phones our office and lets us listen to GSB coming in on his set. M. Hauser in Indianapolis writes, "I wired your excellent kit and had it working in no time. In less than a week I have 'bulled in' 112 stations, 43 of which are distant foreign stations! All were received with remarkable volume and clarity!"

These are only a few of the hundreds of unsolicited letters from delighted purchasers we constantly receive. RESULTS COUNT! That's one of the reasons why we've been actually swamped with orders for our sensational

12,500 MILE TWO TUBE RECEIVER

Results that make the novice tingle with delight and which thrill even the hard-boiled "old-timer"! Results that make the editors of leading magazines and newspapers write articles glowing with praise! Results that in unbiased, competitive tests put to shame all other one and two tube "wonder" and experienced short wave engineers!

The other reason is VALUE!

"How are you able to sell these neat, professional appearing receivers for only \$4.75," we are constantly asked. We answer, "By making only a small margin of profit and letting the sensational VALUE and astounding RESULTS boost our sales into tremendous quantities!"

But, wait! Don't let the low price fool you! It does not mean that we have sacrificed quality! On the contrary, these kits are composed of the finest materials available—HAMMARLUND Condensers—Polymet—SAMSON large Audio Unit—CIL—Allen-Bradley, etc. All HF insulation is of genuine Bakelite. The four coils (15 to 200 meters) are wound on polished Bakelite forms. All losses are minimized! The heavy crystal finished metal chassis has all holes drilled and this, together with the DRY CELL or AC MODEL—COMPLETE KIT

The Ideal Beginner's Set!

\$4.75

The FULTONE II

- SCREEN GRID
- POWER PENTODE

A modified version of the well known 12,500 Mile Two Tuber which uses a 32 screen grid detector and a 33 power pentode output tube. (Dry cell operation.) This combination results in even more sensitivity and volume! An excellent and time proven Short Wave Receiver.



Complete Kit, including coils (15 to 200 meters), heavy, attractive metal chassis and cabinet with hinged cover, and clear instructions..... \$5.75
Set of Matched Tubes \$1.75

ACCESSORIES

GOOD TUBES, carefully tested and fully guaranteed:
201A-30c 230-64c 56-50c
80 -35c 227-35c 53-\$1.06

Imported Lightweight Headphones
2000 ohm—\$1.05 4000—\$1.45 Supersensitive—\$1.90

AC POWER PACK

Delivers 2½ volts filament and 250 volts plate supply for any receiver or transmitter using up to 4 tubes. Uses 280 rectifier. Provision for dynamic speaker field. Complete kit including stamped metal chassis and full instructions..... \$4.85
2½ Volt Filament Transformer..... .95
Dry Cells.....\$1.25 Large 45 Volt B Batteries .95
Neat crackle finished metal cabinet with hinged lid for the Doerle 12,500 Mile kit described above. Protects tubes, coils and wiring from dust and damage..... \$1.00
Set of two coils for the Doerle or Fultone II. Tune from 200 to 625 meters. Enables you to hear all the regular broadcast stations and the long wave ship and press transmissions merely by plugging in these coils. Make your set a real All-Wave Receiver! Set of two coils..... \$1.25
We will completely wire and test any of the above kits, when ordered, for \$1.50.

COMPLETE STOCK OF ALL
NATIONALLY ADVERTISED PARTS.
VISIT OUR NEW SALESROOM!

HAMMARLUND "PRO" COMET

LATEST MODELS Factory Guaranteed—Standard Chassis— \$79.38

Metal Cabinet \$8.82
RCA Tubes 7.17
Automatic Volume Control Model, add 17.64

— SPECIAL OFFER! —
Transportation prepaid to any part of the U. S. A.!

SIMPLEX (General Electric) SOLDERING IRON

Here's a really fine electric soldering iron that will last a life time. 110 Volt AC-DC. A real bargain! Regular selling price \$4.50.

OUR BARGAIN PRICE \$1.95

"Soldermaster." An excellent light iron for all radio work. Good element, approved cord, unbreakable plug. Regular Value \$1.50. SPECIAL \$1.89
6 ft. Spool Rosin core solder..... \$1.00
Deposit required with all orders.

HARRISON RADIO CO.

Dept. C-4 New York City
142 Liberty Street

★ ★ THE HOME OF FOUR STAR SERVICE ★ ★

OF COURSE

this is not the sort of magazine that you read and then discard.

Readers keep their copies for years as a steady reference and thousands of letters attest to this.

It is now possible to save your copies and for this purpose we designed a splendid binder for you which holds twelve copies. It is made of heavy substantial material and is covered with black grain leatherette. The name of the magazine is stamped in gold on the cover.

An ingenious mechanical arrangement is provided which makes it possible to hold the copies flat when reading from the binder.

SHORT WAVE CRAFT Binder as described, \$1.25
prepaid in the United States.....

Canada and foreign countries 25c extra. We accept money order, check, stamps or cash.

SHORT WAVE CRAFT

98 Park Place New York, N. Y.

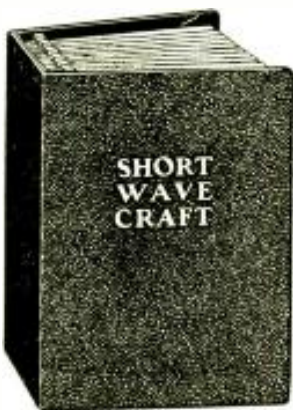

we have *band-spread*, just where we want it. To engage the two condensers the dial must be turned back to the position where the shaft was pulled out. In this manner we can have *band-spread* at any part of the short-wave spectrum, by just pushing a button!

Parts List for the Unitrol

- 1 two tube drilled chassis, Harrison Radio. (Blan.)
- 1 20 mmf. tuning condenser, Hammarlund. (National, Cardwell.)
- 1 140 mmf. tuning condenser Hammarlund. (National, Cardwell.)
- 1 0-100 mmf. antenna trimming condenser.
- 1 100 mmf. mica grid condenser.
- 1 250 mmf. mica condenser.
- 1 .002 to .004 mf. mica condenser.
- 1 2.5 M.H. r.f. choke; National.
- 1 .01 mf. condenser.
- 1 .5 mf. condenser.
- 1 5 meg. grid-leak, 1/2 watt. Lynch. (Int. Res. Corp.)
- 1 2 meg. grid-leak, 1/2 watt. Lynch. (Int. Res. Corp.)
- 1 50,000 ohm resistor, 1 watt. Lynch. (Int. Res. Corp.)
- 1 50,000 ohm potentiometer. Acratist. (R. T. Co.)
- 1 20 ohms or less, rheostat. (R. T. Co.)
- 2 4-prong wafer sockets. Na-ald.
- 1 5-prong wafer socket. Na-ald.
- 1 set of four 4-pin plug-in coils—15 to 200 meters. Alden. (Gen-Win.) See page 749 for coil data.
- 1 National type "B" dial.
- 1 Phone terminal strip.
- 1 Audio transformer.
- 1 32 tube; R.C.A. (Arco.)
- 1 33 tube; R.C.A. (Arco.)

**New All-Wave Set
Features Quadri-Color
Tuning Scale**

(Continued from page 732)

obtained without the danger of reaction between the various tuned circuits. A 2A6 is used as a second detector and automatic volume control tube. Automatic volume control is really more important in short-wave reception than on the regular broadcast band. As *fading* on the short-wave broadcast bands is

of the rapid and more radical type, for true comfort on a short-wave receiver intended for broadcast reception without automatic volume control, one would be continually adjusting a manual volume control. A 2A5 is used as a power amplifier tube and drives a full-sized dynamic speaker at full volume. The tone control is incorporated in the plate circuit of this stage and consists of the well-known condenser-resistor arrangement; it helps out decidedly in tuning in "foreign" short wave stations, especially in eliminating the hiss or noise on some carriers. The power supply consists of an 80 rectifier tube and the field coils of the dynamic speaker are utilized as the filter choke.

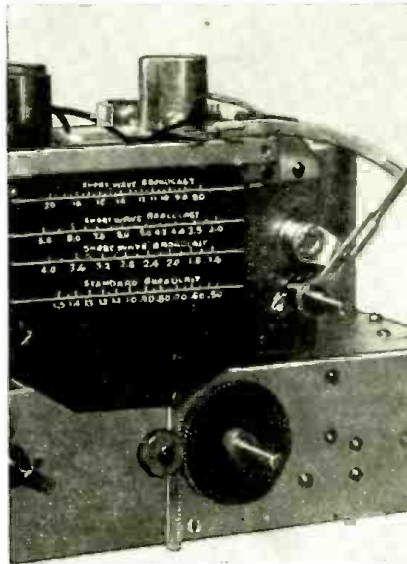

Close-up of 4-scale dial.

**"Long Waves Obsolete" says
Father Charles E. Coughlin**

"I believe that long wave radio is obsolete," was his rather amazing reply. Long wave radio, you know, is employed by the networks and stations about the country to bring your regular radio fare into your home. "The short wave is really the thing," he continued. "I can tune in Petrograd, say at 6, and hear a beautiful feminine voice giving an explanation of Communism. "I can dial Germany at 7 and listen to a talk on Hitlerism. The talk may even be in French or English. At 8, I can dial Italy and hear Mussolini's representative, whom Cicero never equaled as an orator. "One big station will do the trick," he said, thoughtfully. "It will offset the lopsided comments which come to newspaper offices."—From an interview with Rob't. S. Stephan, in the Cleveland "Plain Dealer".

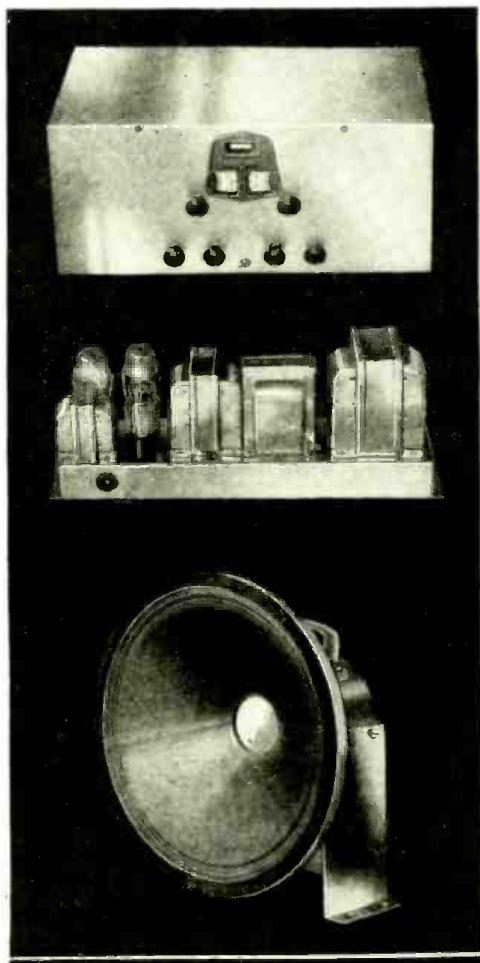

BYRD'S CHOICE!

Why not Yours?

Chosen for 10 to 570 meter work on the Byrd Antarctic Expedition, **MASTERPIECE II** is, by this very token, the most competent all-wave receiver available to you.

To Admiral Byrd, absolute dependability in the matter of transoceanic reception is a vital necessity. Realizing this fact, from his previous experience in the Antarctic, Admiral Byrd selected Masterpiece II for "all-wave" work only after exhaustive tests had proved it thoroughly capable of daily reception from all parts of the world.

Truly enough, such performance is not of life and death importance to you . . . it is not absolutely necessary that you be able to tune in stations 10,000 miles distant simply for pleasure's sake . . . but there IS a tremendous amount of satisfaction in owning a receiver that WILL give you WHAT you want WHEN you want it. THAT receiver, as conclusively demonstrated by Admiral Byrd's choice, is **MASTERPIECE II**.

McMurdo Silver, Inc.
1747 Belmont Avenue
Chicago, U. S. A.



Photo of McMurdo Silver and Admiral Richard E. Byrd, U. S. N. taken just before the start of the second Byrd Antarctic Expedition

10 DAY TRIAL

You are entitled to the same quality of radio performance that Admiral Byrd and others insist upon. I guarantee that my Masterpiece II will give you that kind of performance . . . but I let you be the sole judge. Either you get what you want out of my Masterpiece II or you get your money back instantly, without question or argument. It's just as simple as that. My new book tells all about this offer and gives full technical details of Masterpiece II. The coupon will bring it.



McMurdo Silver, Inc., 1747 Belmont Ave.
Chicago, U. S. A.

Send me full technical information on Masterpiece II.

Name.....

Street.....

Town.....State.....

The 1-Tube S-W Scout

(Continued from page 736)

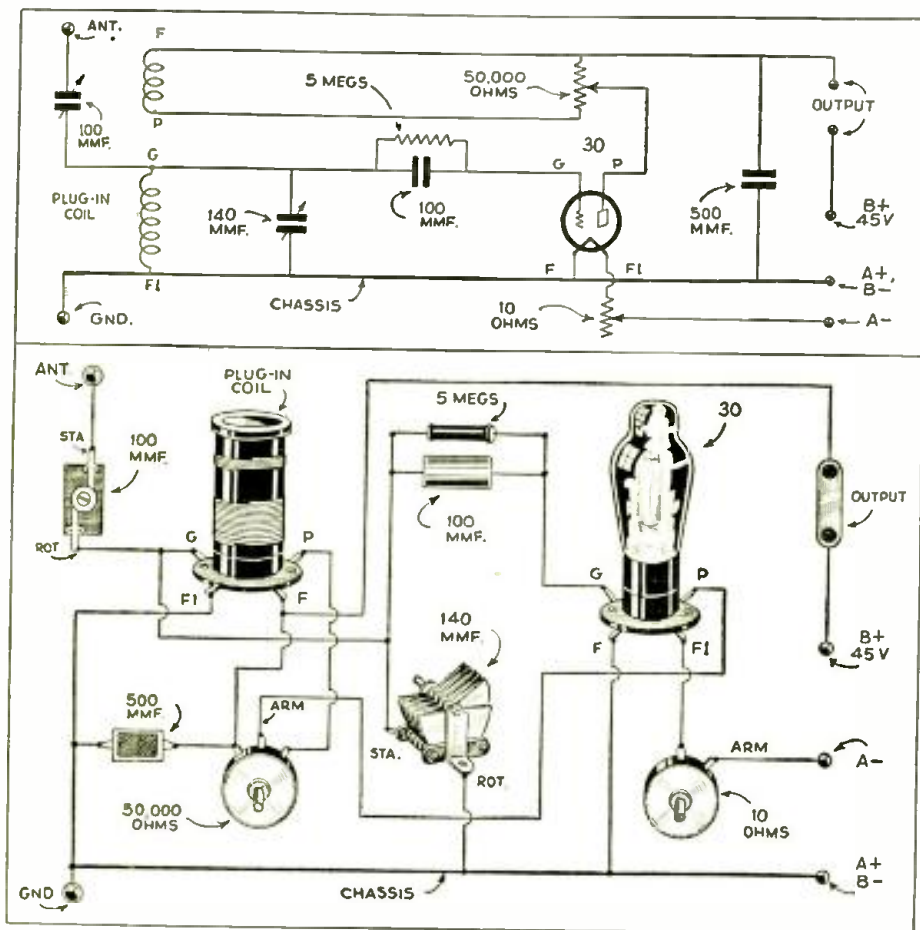

This simplified "picture diagram" of the 1-tube "Scout" receiver should make it possible for anyone to build it.

control and high sensitivity. Regeneration control is connected in a somewhat unusual manner in that the total resistance of the potentiometer is connected directly across the tickler coil, while the contact arm of the potentiometer is connected directly to the plate of the 230 tube. Regeneration control of this form is very smooth and provides a minimum of *detuning* effects. A 500 mmf. condenser is connected directly from the tickler side of the earphones to ground, in order to provide a low resistance path for the R.F. to ground. This also aids in keeping radio frequency currents from getting into the earphones and eliminates *detuning* of the signal when the earphones or phone cords are handled.

A 10 ohm rheostat is provided in the filament circuit to reduce the filament voltage which should be supplied by two 1½ volt No. 6 dry cells to two volts. It is advisable to run the filament with as low voltage as possible and still maintain high sensitivity, in order that the filament of the tube will give normal length of life.

Tuning this receiver is not at all complicated. After the batteries are connected connect the antenna and loosen the 100 mmf. antenna coupling condenser to minimum capacity. Turn the regenerative control to the right until a soft *rushing sound* is heard in the earphones. This will indicate that the tube is oscillating. Now, turn the 140 mmf. grid tuning condenser until the characteristic "whistle" of a station is heard. Then reduce the regeneration until the "whistle" disappears, retuning the grid condenser for maximum volume of signal. When searching for stations it is advisable to keep the tube in an oscillating condition, so that each station will present a "whistle", and there will be no danger of passing over a distant station. An ordinary single wire antenna from 30 to 100 feet

long can be used in conjunction with a good *ground* connection, preferably to a water pipe. However, it is advisable to keep the antenna as high as possible.

Parts List—1-Tube "Scout"

- 1 metal chassis Try-Mo Radio
- 2 4-prong wafer sockets. Na-ald
- 1 140-mmf. variable condenser. Hammarlund (National)
- 1 10-ohm rheostat
- 1 50,000-ohm potentiometer
- 1 5-meg. gridleak. Lynch (I. R. C.)
- 1 100-mmf. mica condenser
- 1 500-mmf. mica condenser
- 1 antenna trimming condenser (100 mmf. low min.)
- 1 antenna-ground binding post strip
- 1 phone terminal strip
- 1 4-wire battery cable
- 1 set, 15-200 meter coils. Try-Mo (or any standard two-winding coils. See data below).
- 1 UX230 tube, R.C.A. Radiotron (Arco.)

Coil Data—16 to 200 Meters

Coil	Grid	Plate	Size Wire	Space between windings
No. 1	5	5	24 d.c.c.	¼ inch.
No. 2	10	7	24 d.c.c.	¼ inch.
No. 3	19	10	24 d.c.c.	¼ inch.
No. 4	45	16	28 enam.	¼ inch.

All windings close wound on 1¼ inch forms.

ULTRA SHORT WAVES—AND HOW!

One hundred mile range on 3/100th of a watt, at a wavelength of 1/2000th of a millimeter! Don't fail to read all about it in George W. Shuart's feature article to appear in the "May" issue!

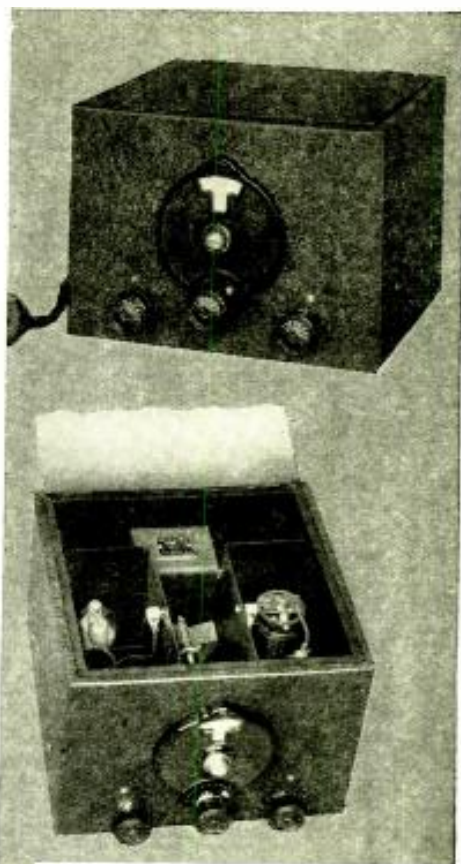

CONFIDENCE

The owner of a NATIONAL SW-3 uses it with confidence. Here is a short wave receiver that has come through every test with flying colors. In amateur stations in every world-district,—on tropical expeditions, in the Arctic and Antarctic, on airplanes, on mountain-tops, and on the sea, the SW-3 is daily doing its work; efficiently and reliably. Universally used, it gives its owners maximum sensitivity and flexibility with the fewest tubes, the least auxiliary equipment and the lowest initial expense.

Send coupon below for new Catalogue No. 220

NATIONAL SW-3 SHORT WAVE RECEIVER

COUPON



NATIONAL COMPANY, INC.
MALDEN, MASSACHUSETTS

Gentlemen:

Please send me your new catalogue No. 220. I enclose 6c to cover mailing costs.

Name

Address

SWC-4-34



HOW TO BUILD, TEST AND REPAIR RADIO SETS



Radio Construction Library

Including Television, Short-Wave Receivers and Auto Radios. 3 Volumes, 6x9—1177 pages, 561 illustrations.

This practical Library includes: PRACTICAL RADIO—The fundamental principles of radio, presented in an understandable manner. Illustrated with working diagrams. PRACTICAL RADIO CONSTRUCTION AND REPAIR—Methods of locating trouble and reception faults and making workmanlike repairs. Discusses modern Short-Wave Receivers and installations of automobile radios fully. RADIO RECEIVING TUBES—Principles underlying the operation of all vacuum tubes and their use in reception, remote control and precision measurements.

Helps you to understand modern type receiving sets—full of construction data and practical kinks for the experimenter—a training course for service men.

10 Days' Free Examination Easy Terms

Free Examination Coupon

McGraw-Hill Book Company, Inc.
330 West 42nd Street, New York

Send me the new RADIO CONSTRUCTION LIBRARY, three volumes, for 10 days' free examination. If satisfactory I will send \$1.50 in ten days, and \$2.00 a month until \$7.50 has been paid. If not wanted I will return the books.

Name
Home Address.....
City and State.....
Position.....
Name of Company..... SWC-4-34

5 in 1 SW BOOSTER

BY POSTAL



A "God-send" to the Short Wave Fan and Amateur. With the new Postal 5 in 1 Short Wave Pre-selector and Booster, you can easily increase the sensitivity and selectivity 300%.

Completely eliminates repeat spots, image frequencies and increases the signal to noise ratio tremendously. The Postal Booster is a genuine two-stage tuned RF pre-selector. Entirely shielded and self-powered and uses the new drawer coils. For AC, DC or battery. Installed in a minute. Guaranteed. Will operate on any Tuned RF or Superhet Short-Wave receiver. (Send a stamp immediately for a complete Descriptive Circular and Special Price for the latest Short Wave SENSATION.)

POSTAL RADIO

135-B LIBERTY ST., N. Y. C.



I'm the Pretzel Bender
... I'll see you on

PAGE 743

The Handy SERVICE MEN'S MANUAL

Profitable Data NEWBORN'S MANUAL

SEE BACK INSIDE COVER FOR BIG AD

25¢

TRY-MO RADIO COMPANY, INC.
895 COBURN ST. N.Y., N.Y.

Why Battery-Operated Sets Are Better

(Continued from page 736)

However, the efficient use of batteries minimizes this handicap and after all, if you want results, you do not mind attending to the batteries once in a while. The "B" batteries last many months in properly designed receivers, and the use of the economical 2-volt tubes with an Air-Cell battery for the "A" supply gives almost as many hours of service as the "B" units, depending, of course, on the number of tubes used.

Cost of Receiver and Operation

The third point mentioned above refers to the relative cost of battery and power operation. This is a question which cannot be settled as easily as the other two.

It must be remembered that the original cost of a battery receiver is lower than an equivalent A.C. set, especially if you construct it yourself. As there are no expensive power transformers, filter chokes, rectifier tubes, and high capacity condensers to buy, an equivalent battery set can be constructed for much less than an A.C. receiver.

While the actual cost of operation depends on the location of the individual experimenter, due to the fact that electric light facilities vary in cost, it can generally be stated that there is not much difference in the cost, whether you pay it in the form of new batteries, or as an additional charge on your electric light bill.

Practical Use of the 2-Volt Tubes

To the "dyed-in-the-wool" short-wave enthusiast, efficiency of operation is paramount. The slight inconvenience in the use of batteries or the slightly greater cost (if any) of battery operation is many times over-balanced by the quietness of operation of correctly designed battery sets.

Since the 2-volt tube is the logical solution to the battery operation problem, it might be well to dispel a false idea impressed on the minds of some experimenters regarding the 2-volt tubes. It has been rumored around that these tubes do not stand up well.

This is not true, as careful laboratory tests have proven. Although these tubes do not have as husky filaments as their A.C. cousins, they are capable of just as long service as the latter, providing the filament voltage is kept within the safety limits set by the manufacturers.

The trouble has been that these tubes have been used almost exclusively with ordinary dry cells, which vary in voltage from 3.2 volts (for batteries having a series-parallel connection with two cells in series) when new, to zero over their useful life, which necessitated continuous adjustment of the filament rheostat. This change in voltage is shown in Fig. 1. Also, as the volume of a set using these tubes could be increased by increasing the voltage on the tubes above the safety point, they were seldom operated at the correct temperature and the result was an annoyingly short life.

The Air-Cell battery for which these tubes were designed, on the other hand, has an unusually constant voltage from the beginning to the end of its useful life. This is shown also in Fig. 1. It will be noted that by the use of a fixed resistance in series with the filaments of the tubes, the terminal voltage on the filaments can be maintained within the specified limits of the tube manufacturers for a period longer than the rated ampere-hour capacity of 600. Also, by the use of a fixed filament resistor instead of a rheostat, the tendency to overload the tubes is obliterated.

Figure 2 shows the correct method of connecting the fixed resistance for sets of the regenerative or T.R.F. type, in which the circuits for all tube filaments are the same.

In recent superheterodyne receiver designs for all-wave or short-wave ranges, the 1A6 pentagrid converter tube is equipped with coupling coils or choke coils, or both, in the leads to the filament. As these coils have some resistance (usually adjusted to 4 ohms) the filament of this tube cannot be operated in parallel with the others in

the set, by using the same fixed resistance for dropping the battery voltage to the correct value for the tubes. If this was done, the 1A6 would not be supplied with sufficient filament voltage, with a resulting loss in volume or lack of oscillation. As a result, the circuit of Fig. 2 has to be revised somewhat and an arrangement such as that shown in Fig. 3 is used. By using coils with a resistance of 4 ohms and two fixed voltage dropping resistors, R1 and R2, as shown, the correct filament voltage is applied to all the tubes of the set. The actual values of resistors R1 and R2 depend on the number of tubes in the set. The values can be found by Ohm's law.

The "Air-Cell" Battery

We have stated that the reason why many experimenters have not received good service with the 2-volt tubes is because they tried to use ordinary dry cells. The success of the Air-Cell is in its constant voltage.

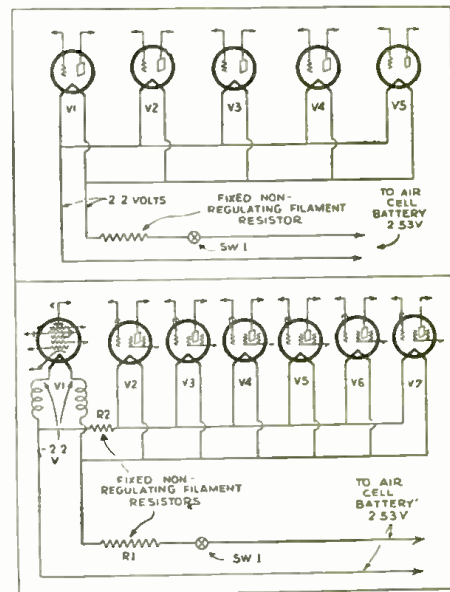

Different methods of connecting tubes for operation on "Air-Cell" battery. Fig. 2 above; Fig. 3 below.

The Air-Cell battery is a special type of primary cell. In developing this new battery, the manufacturer resorted to an old idea in battery construction. This is "air depolarization," which simply means that the oxygen essential to the continued operation of the battery is obtained from the air instead of from oxygen-bearing chemicals packed into the case. This problem is solved by a special form of carbon which has the peculiar property of extracting oxygen from the outside air, and in a form suitable for the necessary chemical reactions in the battery.

As the primary battery thus developed "breathes" its oxygen out of the air it is called the Air-Cell battery. The depolarizer is one of the most important parts of a battery as anyone who is familiar with the operation of the primary cell knows. It always takes up considerable space in the cell and in addition it is expensive and adds to the weight. But in the Air-Cell battery, it takes up no space, being drawn in from the atmosphere only as needed and it costs nothing. This is what makes the Air-Cell battery the cheapest form of primary power as well as the lightest. Compared with "A" batteries made of groups of dry cells, it gives approximately twice as many ampere-hours of output per dollar of cost and per unit of weight.

From the above explanation, it becomes evident that battery operation, properly worked-out, is preferable to any other method for the short-wave set, both from the standpoint of smooth, quiet performance and of economy.

3-4 Meter Portable

(Continued from page 715)

chokes are exactly the same as is illustrated in figure 1; L3 is the first detector inductance, consisting of a half circle of No. 12 copper wire, two inches in diameter. The first detector is capacitively coupled to the high frequency oscillator by C3.

The intermediate transformers used were tuned to approximately 175 kc.; greatest efficiency was gained by the use of intermediate frequency transformers tuned to this range. The complete receiver is housed in a shielded cabinet. At present the writer is employing type A.C. tubes; better results would be obtained by using battery supply, as then A.C. line noises are entirely eliminated. The receiver is not critical in tuning as one might expect, but tunes fairly broad and has a high degree of sensitivity; it might be stated here that a loud signal was received up to a distance of 1/2 mile with no antenna used on the receiver at all!

Parts Used to Build the 75 Centimeter Receiver

- 2 type 230 tubes, R.C.A. (Arco.)
- 2 type 232 tubes, R.C.A. (Arco.)
- 1 type 233 pentode tube, R.C.A. (Arco.)
- RFC—1, 2, 3, 4 (see text)
- L-1, L-2, two lengths of No. 12 copper wire, 12" in length, spaced 3" apart
- C-1 .00035 mf. variable condenser, National (Hammarlund)
- C-2 100 mmf. variable condenser, National (Hammarlund)
- C-3 .00005 mf. fixed condenser

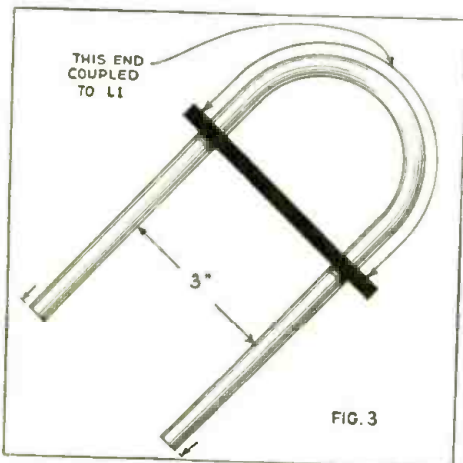

Wave-measuring device.

- C-4 .00025 mf. fixed condenser
- C-5, C-6, C-7, C-8, intermediate frequency transformer trimmers (30 to 70 mmf.)
- R-1 50,000 ohms, Lynch (I. R. C.)
- R-2 500,000 ohms, Lynch (I. R. C.)
- R-3 500,000 ohms, Lynch (I. R. C.)
- R-4 1-megohm, Lynch (I. R. C.)
- SW filament switch
- 1 9-volt C-battery
- 3 45-volt B-batteries
- 2 1 1/2-volt filament batteries
- L, L-2, L-3 and L-4, int. freq. transformers, 175 kc. Gen-Win.

The Lecher Wire System for Calibrating the Wavelength in Centimeters

A conductor is "shorted" across the two wires and moved until a dip is noticed in the oscillator plate current, indicating resonance, the distance indicated by the arrow is then measured with a centimeter scale or rule.

A.C. Transmitter

Figure 2 illustrates a circuit for complete AC operation of the 75 centimeter transmitter; this transmitter was used up to distances covering 6 miles; the quality of the speech at the receiving end was excellent. The type tubes employed in the circuit are the 5B3 high frequency oscillator, a 56 used as the speech amplifier. A type 45 tube was used as the modulator.

(Continued on page 754)

I WOULD LIKE TO HAVE SOME SUPPLIES SHIPPED RIGHT AWAY UNCLE DAVE

UNCLE DAVE

356 BROADWAY
ALBANY-NEW YORK
WE BUY-SELL & TRADE HAM STUFF
24 HOUR SERVICE-WITH SPECIAL ATTENTION TO ALL ORDERS

OK-OM-UNCLE DAVE! GOT YOUR ORDER IN THE HAND OF THE U.S. MAIL READY FOR DELIVERY-THATS SERVICE

- #### TRANSMITTERS
- PEERLESS RADIOPHONE TRANSMITTER, complete with microphone, tubes, milliammeter, ready to plug into 110 volt 60 cycle A.C. supply. SPECIAL.....\$38.50
 - Above transmitter, crystal controlled with crystal ground to your frequency in 160-meter band..... 41.25
 - PEERLESS JUNIOR TRANSMITTER, complete with tubes, power supply, 40-meter coils, wired and tested..... 10.95
 - PEERLESS SENIOR TRANSMITTER, complete with heavy power supply, 2-245 tubes, an 83 tube, milliammeter, approx. 10 watts output, wired and tested..... 16.25

ROUND THE WORLD RECEIVERS

ALL BRAND NEW-MADE WITH FIRST QUALITY PARTS

LOOK!

	Kit Form.	Wired, Tested and Assembled.
PEERLESS 1-tube Blackhawk	\$3.89	\$4.89
PEERLESS 2-tube Junior receiver	4.75	6.15
PEERLESS 2-tube Loudspeaker receiver	7.95	8.95
PEERLESS 3-tube Professional	9.50	10.95
PEERLESS 4-tube AC-DC receiver (new tubes equiv. to 8 ordinary tubes)	21.50	24.50

Write in for detailed descriptions of above as well as other type receivers to fit your pocketbook.
Let us also quote you on the latest National and Hammarlund Receivers!

LOOK!

- #### CRYSTALS
- PEERLESS CRYSTAL OVEN, COMPLETE WITH CRYSTAL, \$8.25; less Xtal.....\$6.50
 - PEERLESS PRECISION CRYSTALS, ground anywhere in the 80 or 160 meter band, complete with moulded bakelite adjustable holder..... 2.75
 - PEERLESS PRECISION CRYSTAL, with commercial plug-in precision holder..... 3.60
 - 7000 kc. PEERLESS CRYSTAL..... 5.50
 - Finished oscillating blank..... \$1.60
 - Unfinished blank..... 1.00
 - PEERLESS Moulded bakelite adj. dustproof crystal holder, each..... .74
 - Same type as above, but plug-in holder..... 1.05
 - PEERLESS COMMERCIAL type plug-in precision crystal holder, each..... 1.29

Write in to Dept. "SW" for copy of our latest "Ham" Bulletins and Hot Specials!

Foreign trade solicited! Include at least 20 Per Cent Deposit with all C.O.D. Orders. Cable Address: "UNCLEDAVE"

UNCLE DAVE'S RADIO SHACK

356 BROADWAY, ALBANY, N. Y. LONG DISTANCE PHONE 4-5746

A New Kind of Short-Wave Radio

the SKY-RIDER

Another FIRST by the HALLICRAFTERS

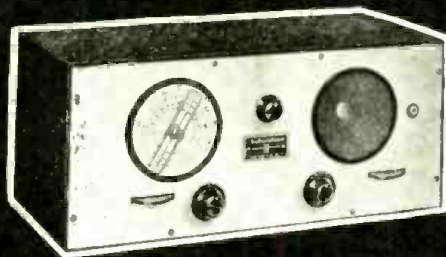

An all-wave receiver development that makes possible the most dependable short-wave reception ever known.

A new circuit employing entirely different units and construction. Offered at lower cost than any other modern short-wave receiver.

No other receiver, regardless of price, offers all these features:

Low-loss wave change switch, modified band spread, 200 to 12 meter tuning range divided into 4 bands, micro-vernier tuning control, 18 to 1 ratio, dual gain controls—and many more, all described in the new HALLICRAFTERS "SKY-RIDER" booklet. Write for your copy today!

SKY-RIDER Receiver, with dynamic speaker and power pack, 5 tubes. Net to dealers and servicemen, \$39.95.

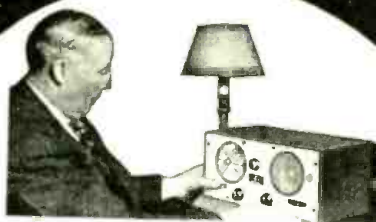

This set is NOT with Byrd
—but it brings Little America to Capt. Bartlett daily

Though the HALLICRAFTERS SKY-RIDER had not been released from its intensive laboratory and field tests before the Byrd Expedition sailed, it is serving to keep Capt. Bartlett, the highest ranking survivor of Admiral Peary's famous dash to the Pole, in constant daily touch with his friends at Little America. You, too, can have the thrill of hearing Little America direct if you own the new SKY-RIDER Short-Wave Receiver.

Mail Coupon Today

Radio "Cop" Has A-1 Station

(Continued from page 713)

Turned up, it could broadcast foreign stations all over the neighborhood—which sometimes didn't agree with neighbors who have no esthetic taste for the finer things in French, German, Spanish and Russian.

Mickelson had joined the Minneapolis police force in 1925.

For several months, he had served on the morals squad, later alternating between patrolling a beat in winter and serving on the motorcycle squad in summer.

But at request of Captain George Hillstrom, he went into the radio room as operator and dispatcher. Letters came from all over the North American continent, from Cuba and other islands in the West Indies, telling of the clarity with which the station had been received.

While he's serving on other assignments again now, he has his little radio world up in the attic of his home.

A neat den, its hand-made rug on the floor, the walls lined with books, nearly all of them on radio; three fine receiving sets; two microphones; a transmitting key; verification cards of stations from all over the world papering every available space on the walls.

He's experimented extensively with antennae, and has built some 200 of them.

But the one he has now is his pride. It has a fancy name—a "transposed antenna," he calls it—and it does fancy things with short waves.

To describe it isn't so easy; but for people interested in that sort of thing, it's in a T shape, with the lead-in exactly in the center.

Each top bar of the T is exactly 33 feet, 3 inches long, and the lead-in is 66 feet, 6 inches long. But if you must ask why, you'd better ask Mike. He will tell you its got something to do with peak reception.

Unlike the ordinary aerial that dubs put up on their five-tubers to get in the football games and dance music, the horizontal part of the T isn't in a continuous wire.

The wire runs from each end of the T to the center, and there dips downward to form the lead-in. That makes two lead-in wires instead of one to form the vertical part of the T. And these—again, if you must know why, ask Mike—are crossed over every 18 inches, but by means of insulators are kept from touching each other at those points.

That, for some reason that radio men know but can't explain very well to unmathematical minds, makes a radio work better on the 20 to 40 meter wave bands.

With this antenna, Mickelson has pulled in stations of whose existence he never knew, stations unrecorded in any log books but the most complete.

Spain and France, Germany and England, are the run of any night. He's registered such stations frequently as VQ7LO, Nairobi, Africa; RV59 in Moscow, Russia.

And those, on a set built largely from leftovers not with faint and whispering signals but with volume crisp and clear.—*Courtesy Minneapolis Tribune.*

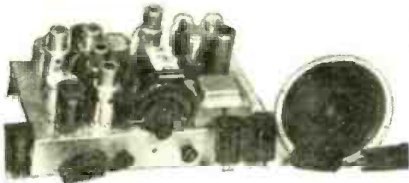

Foreign Reception Guaranteed

ON NEW SUPERBA SHORT WAVE SET

The circuit is a seven tube superheterodyne, using two plug-in coils for each band, total four bands, or eight coils.

A separate 56 tube is used as oscillator, while the modulator is the most sensitive of them all, a 57. The reason for the separate local oscillator is that the degree of coupling can be controlled in the coil.

COMPLETE KIT OF PARTS INCLUDING SEVEN TUBES

Cat. SUB-K—Complete kit for the Superba Short-Wave Receiver, including the following Arcurus tubes: One 57, two 58's, one 2A6, one 2A5, one 56 and one 80. All

parts absolutely furnished, including coils and diagrams, except only cabinet and front panel. Price\$29.88

THE WIRED MODEL, WITH TUBES

For those who do not desire to wire the set themselves we will wire in our laboratory and carefully adjust and line it up, so that stations the world over will come pouring in.

Cat. SUB-W.—Wired model, design hence most astonishing delights are experienced even on very highest frequencies, around 20,000 kc., when not only low-priced short-wave sets usually play dead, but even high-priced

ones drop a few buckets of sensitivity. Complete with tubes, less cabinet, less front panel\$33.62

ALL IN A BEAUTIFUL CABINET, READY TO GO

We have also two models of cabinet of the mantel type into which the Superba Short-Wave Receiver can be mounted. One is the Gothic model, with rounded top, the other the Stanton model, with square top. The finish is walnut.

Cat. SUB-WC, wired receiver, complete with tubes, in cabinet (specify which style), all ready to tune in the world\$37.37

Cat. CBS, Stanton cabinet only, or Cat. CGTH, Gothic cabinet only\$3.75

SUPERTONE PRODUCTS CO. 35 S. Hooper St., Brooklyn, N. Y.

SURPLUS RADIO PRODUCTS

• Order Direct from this Advertisement — We Issue No Catalog •

WE HAVE ON HAND

197 JENSEN Auditorium Speakers

MODEL DA-7—D. C. Dynamic CONE SIZE 13 1/2 INCHES



List Price \$45.00

NET TO YOU

\$9.95

ESPECIALLY SUITED FOR THEATRE, PUBLIC ADDRESS OUTDOOR ANNOUNCING

Handling Amplifiers Delivering 20 WATTS 2500 Ohm Field

Push-Pull 247 Output Transformer Shipping Weight 20 lbs.

WE HAVE ON HAND

95 WESTINGHOUSE Power Generators

MANUFACTURED FOR U. S. GOVERNMENT \$75.00 VALUE

Manufactured by Westinghouse for the U. S. Signal Corps, the sturdy construction of this instrument recommends it to the technician.

Build-in commutator takes off the generated D. C. Three leads extend through the casing to permit a 4 1/2 V. flashlight-type battery to be switched into circuit for starting, and to control the A.C. output of the generator. Rotated at its normal speed of 3,500 r.p.m., the output is 200 W., at 115 to 125 V. (on open circuit), 900 cycles.

The rotor turns in ball bearings. Shaft length (driving end), 2 ins.; diameter, 3/16 in.; the end is threaded for a distance of 3/8 in. Case dimensions, exclusive of the shaft, 14 5/8 in. in diameter. Guaranteed new and perfect. Worth \$75.00, but while they last, only \$1.95, plus shipping charges. Shipping weight 13 lbs.

REMIT BY CHECK OR MONEY ORDER FOR FULL AMOUNT OF EACH ITEM—SHIPPED EXPRESS COLLECT. NO C. O. D. ORDER ACCEPTED — MONEY REFUNDED IF NOT SATISFIED.

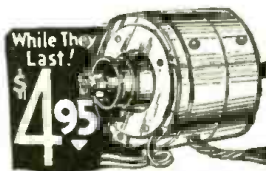

WELLWORTH TRADING COMPANY, 111 West Lake Street, Chicago, Ill. SW-4-34

Enclosed you will find my remittance of \$..... for which please send me by express collect:

- () Jensen 13 1/2 Auditorium Speaker, \$9.95 each
- () Power Generator, \$1.95 each

ADDRESS.....

STATE.....

FREE TO YOU

list in which we have compiled all articles which have appeared in SHORT WAVE CRAFT. This list fully informs you

are still available. If you are interested postage and it will be sent immediately.

96 PARK PLACE NEW YORK, N. Y.

For The BEGINNER!

Don't Miss

The 1-TUBE "ELECTRODYNE"

Article fully describing this superior 1-Tube S-W Receiver designed by LEONARD VICTOR will appear in the

MAY ISSUE!

The "RT" 5-Meter Transmitter

(Continued from page 738)

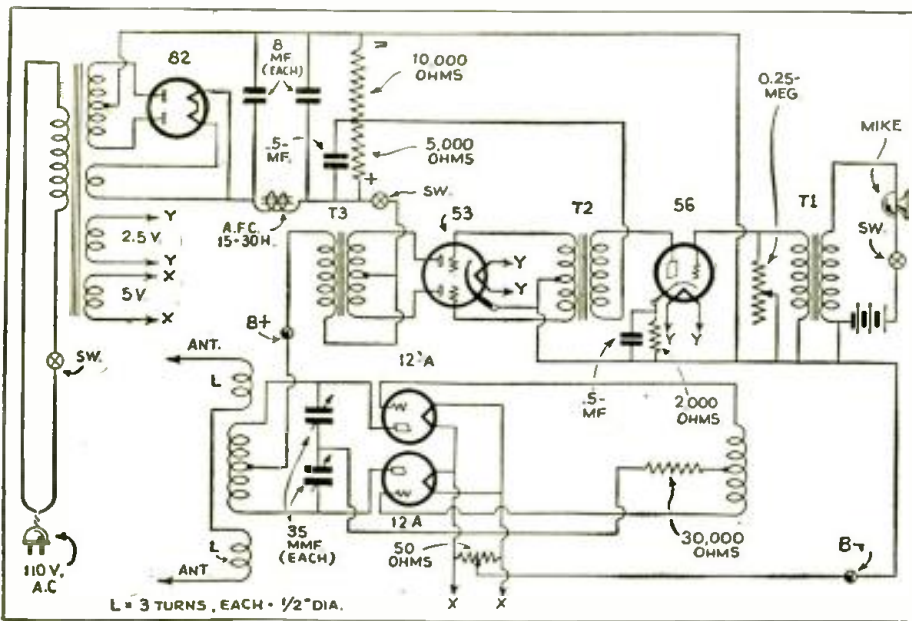

Hook-up of 5-meter "RT" transmitter.

used to insure a minimum of losses. All wiring in the oscillator circuit should be done with No. 12 solid copper wire.

Parts List—5 Meter Transmitter

OSCILLATOR

- 1 set of coils (see text)
- 1 split stator tuning condenser, 35 mmf. per section (Hammarlund)
- 2 4-prong isolantite sockets, National (Hammarlund)
- 6 tiny stand-off insulators (Birnbach)
- 1 30,000 ohm 5-watt grid-leak (wire-wound)
- 2 112A tubes, R.C.A. Radiotron (Arco)

MODULATOR—POWER SUPPLY

- 1 power transformer (heavy duty) (R. T. Co.)
- 1 15 to 30 henry filter choke (heavy duty; 175 M.A.), National (R. T. Co.)

- 1 microphone transformer, National (R. T. Co.)
- 1 class "B" input transformer (to couple 56 to 53). (R. T. Co.)
- 1 class "B" output transformer (to couple 53 to 4,000 ohm load). (R. T. Co.)
- 1 15,000 ohm voltage divider tapped at 5,000 (50 watts). (R. T. Co.)
- 2 2,000 ohm 1 watt resistor, Lynch
- 1 250,000 ohm potentiometer (gain control). (R. T. Co.)
- 2 8 mf. electrolytic condensers, 500 volt (R. T. Co.)
- 2 .5 mfd. bypass condensers (R. T. Co.)
- 1 7 prong wafer socket, Na-ald
- 1 4 prong wafer socket, Na-ald
- 1 5 prong wafer socket, Na-ald
- 1 single-button microphone, Universal
- 1 metal chassis, 8x12x2 inches, Blan
- 1 53 tube, R.C.A. Radiotron (Arco.)
- 1 82 tube, R.C.A. Radiotron (Arco.)
- 1 56 tube, R.C.A. Radiotron (Arco.)

Short Wave League

(Continued from page 737)

There have been many rather silly reasons for dropping the code test given in previous issues of SHORT WAVE CRAFT, which are too obvious to amateurs to require comment. On the other hand, some of the reasons for retaining the code test advanced by amateurs seem equally foolish. One of the most common objections is that the code test is all that prevents the amateur ranks from being over-run with technically incompetent persons. Certainly there is nothing in a code test which accents those technically able and rejects those technically incapacitated. The only way to guarantee this is to incorporate a suitable technical examination. For an Electrical Engineering degree, the applicant is subjected to a rigorous technical examination and if he passes is given his degree. He is not required to memorize ten pages from the Bible, with the explanation that anyone not having sufficient ambition to do a little memorizing is not capable of practicing engineering. Neither is the code test any indication of an amateur's technical ability.

On the other hand, the present examinations will require extensive revision before they give a true indication of the applicants' technical ability. It certainly is a regrettable fact that under the present system, anyone possessing 25c can obtain all the questions ever asked in the Government examinations, together with the correct an-

swers for same. It then becomes merely a matter of memorizing the whole works and a ticket (license) would be assured. Obviously this will never do and it will be necessary to stiffen the "exams" and eliminate stock questions. Since the range of five meter signals is very limited, questions dealing with the international aspects of amateur communication could well be eliminated and technical questions substituted.

Another objection frequently cited against the no code argument is that the holders of the five meter licenses would soon be infesting the other bands. Obviously anyone who would operate a station unlawfully with a five meter license, would just as readily do so without the license, so this cannot be held against the no code proposition.

Another stock objection is that if a ship were in distress and had only five meter equipment available for C.W. transmission, the no code amateur would be of no assistance in furnishing aid to the unfortunate vessel. All the writer can say to this is, that if a ship is in distress and has nothing but five meter equipment—Heaven help it!

In conclusion, the writer would like to point out that in the 56-60 mc. (five meter band) band the amateur has available an enormous range of kilocycles—greater in

(Continued on page 755)

NEW SENSATIONAL OFFER

Learn RADIO

PAY FOR TRAINING AFTER YOU GRADUATE

To a few honest fellows I am offering an opportunity to get a training and pay for it after they graduate in easy monthly payments. You get Free Employment Service for life. And if you need part-time work while at school to help pay expenses, we'll help you get it. Coyne is 33 years old. Coyne Training is tested—You can find out everything absolutely free. Just mail the Coupon for My Big Free Book.

Jobs Leading to Salaries of \$50 a Week and Up

Jobs as Designer, Inspector and Tester—as Radio Salesman and in Service and Installation—as Operator or Manager of a Broadcasting Station—as Wireless Operator on a Ship or Airplane, as a Talking Picture or Sound Expert—Hundreds of Opportunities for fascinating Big Pay Jobs!

10 Weeks' Shop Training AT COYNE IN CHICAGO

We don't teach you from books. We teach you by Actual Work on a great outlay of Radio, Broadcasting, Television, Talking Picture and Code equipment. And because we cut out useless theory, you get a practical training in 10 weeks.

TELEVISION Is Now Here!

And Television is already here! Soon there will be a demand for Television Experts! The man who gets in on the ground floor of Television can have dozens of opportunities in this new field! Learn Television at Coyne on the very latest Television equipment.

Talking Pictures A Big Field

Talking Pictures, and Public Address Systems offer golden opportunities to the Trained Radio Man. Learn at Coyne on actual Talking Picture and Sound Reproduction equipment.

Get the Facts

Don't spend your life slaving away in some dull, hopeless job! Don't be satisfied to work for a mere \$20 or \$30 a week. Let me show you how to make Real Money in Radio—the fastest-growing, biggest money-making game on earth! Get my big Free book and all details of my pay after graduation offer. Mail the coupon today.

H. C. LEWIS, President
 Radio Division, Coyne Electrical School
 500 S. Paulina St., Dept. 44-2K Chicago, Ill.

Dear Mr. Lewis:
 Send me your big Free Book; details of your Free Employment Service; and tell me all about your special offer of allowing me to pay for training on easy monthly terms after graduation.

Name

Address

City..... State.....

"HAM" ADS

Advertisements in this section are inserted at 5c per word to strictly amateurs, or 10c a word (8 words to the line) to manufacturers or dealers for each insertion. Name, initial and address each count as a word. Cash should accompany "Ham" advertisements. Advertising for the May issue should reach us not later than March 5.

FREE RADIO AND MORSE TELEGRAPHY Book. Learn code in short time. New easy method. FISHER ELECTRIC CO., 3801 Riverside Ave., Cleveland, Ohio.

REAL S.-W. CONVERTER. USES TWO Tubes. Fully guaranteed. \$2.00 unit; only half-price. 20TH CENTURY CO., S-3088, Kansas City, Mo.

PLUG-IN COILS. 15-210 METERS 50c PER SET of four coils. NOEL, 809 Alder, Scranton, Pa.

CQ '46's AND '56's: 3 FOR \$1.00. GUAR-anteed perfect new tested tubes—excellent performance (shipping weight 2 lbs.). You can't afford to pass this up (or 50c each postpaid). Increase your output. Don't wait. Supply limited, W9KIU, 3954 Sullivan, St. Louis.

A CHANCE TO GET RADIO PARTS OF ALL kinds in good condition. Will trade for anything useful. Send for descriptive list. A. Stoltman, 275 Martense St., Brooklyn, N. Y.

QSL's, SWL's 75c A HUNDRED; 2 COLORS. W9DGH, 1816 Fifth Ave., N., Minneapolis, Minn.

203A FIFTY WATERS \$9.75 EACH; NEW, first quality and fully guaranteed; also 211's and 845's. VTE Laboratories, Ridgefield, N. J.

CHOKES, 85 MILLIHENRY TRI-SECTION waterproof, uncased, 250 ohms, postpaid anywhere United States, 45c. WOOLCOTT, W7DAG, Cottage Grove, Ore.

BAIRD SW SET, 7 TUBES. PRICE \$25.00. A-1 condition. R. W. STORMER, 21—18th St., Jamestown, N. Y.

QSL CARDS, NEAT, ATTRACTIVE. REASON-ably priced, samples free. MILLER, Printer, Ambler, Pa.

BARGAINS, RADIOS, SUPPLIES. FREE PRICE sheet. GREAT LAKES RADIO, Bay City, Mich.

TEN PRACTICAL AND INEXPENSIVE changes converting Dodge 12-V, Ford T.A., Chevrolet Delco 6-V generators into 100-500 watt capacity A. C. generators, or into 32-110 volt D. C. motor or generator. Dodge is 500-W. self-excited. All in one book illustrated with complete simplified instructions and drawings for only \$1. AUTOPOWER, 414 S. Hoyne Ave., Chicago.

TUBELESS CRYSTAL SET—SOMETHING new. Separates all stations, operates speaker, 1,800 miles verified. Blueprint, 6 others. 25c coin. MODERN RADIOLABS, 151-A Liberty, San Francisco.

SUPER TESTER: TESTS ELECTRICAL short circuits, radio parts, etc. \$1.00. SUPER-TEST, Box 326, Braddock, Penna.

BARGAIN LIST AND EXPERT ADVICE ON your problems for 10c. Excellent 10-watt transmitter, \$5.00; Teleplexes, Microphones, etc., bought and sold. Write today. ROBERT BROWN, Sullivan St., Dolgeville, N. Y.

3-4 Meter Portable

(Continued from page 751)

List of Parts for A.C. Transmitter

- R-1 15,000 ohms, Lynch (I. R. C.)
- R-2 marked (X) 3,000 ohms, Lynch (I. R. C.)
- R-3 100,000 ohms, Lynch (I. R. C.)
- R-4 1,500 ohms, Lynch (I. R. C.)
- R-5 20 ohms, center-tapped resistor
- C-1 1-mf. fixed condenser
- C-2 1-mf. fixed condenser
- C-3 .5-mf. fixed condenser
- MI milliammeter, 0-100 M.A. scale

The New "Stand-By" S-W Receiver

(Continued from page 721)

Other Circuit Considerations

Several other minor features should be noted. First, the use of a *resistance-capacity* filter circuit in the B plus return of the detector tubes. This results in smoother operation and with the use of the .00025 mf. mica condenser absolutely prevents r.f. leakage into the audio stages. This results in great *stability* and *smooth regeneration* control.

Two audio stages with the 33 type pentode in the output stage gives good audio volume and with the audio volume control the phones can be left connected to the output of the pentode and any degree of volume can be obtained as desired.

Facility of Control

A series variable antenna condenser is used in this receiver as in the first "Stand-by" but it has been moved out to the front panel where it serves to smooth out the regenerative action. To use this control to the best advantage it is set to such a value that the regeneration control is operating smoothly over the portion of the S.W. band used. The antenna series condenser then becomes an auxiliary regeneration control for critical control. The proper adjustment of the condenser will remove the dead-spot difficulties so often encountered in the ordinary receiver.

Thus this receiver has a tuning control, a simple regeneration control and a series antenna condenser that minimizes "dead-spots" and serves to smooth out the regenerative action of the main regeneration condenser. An added refinement in the form of a volume control is introduced in the grid circuit of the first audio stage. In other words the detector can be operated at the maximum condition for sensitivity and selectivity and the actual degree of audio volume can be controlled without upsetting the electrical characteristics of the detector circuit. This results in greater apparent selectivity and sensitivity, which is noticeably lacking in the average receiver.

Matched Detector Tubes

As the two detector tubes should work under the same conditions as far as coils, condensers, voltages, leads, etc., are concerned, it is better to have the two tubes match alike in electrical characteristics as well. If possible select two tubes for the detector circuit that have equal mutual conductance and plate current values. Today tube manufacturers can build tubes of the type used in this receiver with a great degree of electrical regularity; thus it will be found that this matter of *electrical matching* of the tubes is quite simple. However, it is necessary to keep all wires and leads running to the coils, tubes and condensers as symmetrical as possible. If there is R.F. entering the audio stages, then there is some portion of the detector circuit that is unbalanced and the set constructor must look the set over and find out what causes this unsymmetrical condition. This will generally be traceable to improper layout and too marked a variation in the length of the leads running to the various parts.

Operating Notes

In operation the set is simplicity itself and like all accurately balanced short-wave receivers should be tuned very slowly and carefully. The antenna series condenser should be adjusted to the point that will make the receiver oscillate when the regeneration condenser is set to the maximum capacity. If the regenerative action does not persist as the tuning condenser is adjusted it will be necessary to readjust the antenna series condenser until regeneration is obtained. In some cases it will be noted that the regeneration condenser changes the tuning slightly, necessitating a slight retuning of the main tuning condenser.

Construction

Remember to use good tubes and high-quality batteries, also sensitive headphones. If you are interested in real reception don't throttle the receiver with a cheap, insensitive pair of phones. Sensitive high-quality phones of 3,000 to 4,800 ohms resistance (for the pair) are available at reasonable prices.

Remember to use the best antenna possible. Build two or three if necessary, and investigate the merits of the new transposed lead-in aerial systems, such as the Lynch. The effort is well worth-while and the results will be surprising.

Parts List—Denton Stand-By

- One National "Velvet-Vernier" Dial, type E.
- Two Hammarlund Type MC 140-M (140 mmf.) Midget Tuning Condensers (National) (C2, C7)
- One Hammarlund Type MC250M 260 mmf. Midget Tuning Condenser (National) (C1)
- Three Hammarlund Flexible Coupling Units
- Three four-prong sockets (V1, V2, V3)
- One five-prong socket (V4)
- One Antenna-Ground Strip (1, 2)
- One Phone Strip (3, 4)
- One 7 wire cable and plug (5, 6, 7, 8, 9)
- One 10 ohm rheostat (R6)
- One Bypass Condenser 2 mf., 200 volts (C6)
- One Tubular Condenser, .1 mf., 200 volts (C5)
- One Bypass Condenser, .5 mf., 200 volts (C4)
- One Tubular Condenser, .00025 mf., 1000 volts (C3)
- One Tubular Bypass Condenser, .01 mf., 400 volts (C8)
- Two Acratost 5 meg. .5 watt resistors (R1, R2)
- One Acratost .5 meg. potentiometer (R4)
- One Acratost 10,000 ohm, 1-watt resistor (Lynch; I.R.C.) (R5)
- One Acratost Audio Frequency Transformer (AFT)
- One Acratost 50,000 ohm, .5 watt resistor (Lynch; I.R.C.) (R3)
- One Acratost 30 Henry Choke (CII)
- One Wooden Baseboard, 9 by 14 inches
- One Blau, 7 by 14. Aluminum Panel
- Three Blau Aluminum Brackets
- Three ¼ inch diameter, 7 inches long, bakelite rods
- Four Phone-tip jacks
- Four standard 1 inch black knobs
- Wire, wood screws, etc.
- Three type 30 tubes. R.C.A. Radiotron (Arco)
- One type 33 tube. R.C.A. Radiotron (Arco)
- 2 vt. (filament supply) Air-Cell Battery (Nat'l Carbon Co.) (optional)

\$20.00 PRIZE MONTHLY FOR BEST SET

● THE editors offer a \$20.00 monthly prize for the best short-wave receiver submitted. If your set does not receive the monthly prize the editors will pay space rates for articles accepted and published.

You had better write the "S-W Contest Editor," giving him a short description of the set and a diagram. BEFORE SHIPPING THE ACTUAL SET, as it will save time and expense all around. A \$20.00 prize will be paid each month for an article describing the best short-wave receiver, converter, or adapter. Sets should not have more than five tubes and those adapted to the wants of the average beginner are much in demand.

Sets must be sent PREPAID and should be CAREFULLY PACKED in a WOODEN box! The closing date for each contest is sixty days preceding date of issue (April 1 for the June issue, etc.)

The judges will be the editors of SHORT WAVE CRAFT, and George Shuart and Clifford E. Denton, who will also serve on the examination board. Their findings will be final.

Short Wave League

(Continued from page 753)

fact than all the kilocycles present above 80 meters. Due to this large territory and the limited transmission of five-meter signals, millions of stations could satisfactorily operate in this band. The existing 40,000 amateurs cannot hope to show proper occupancy of this band and hence should be willing and anxious to remove all "artificial barriers" on this band in order to get all the short-wave listeners (having proper technical knowledge) possible into the fold. Then proper occupancy can be demonstrated and the present band retained for amateur use.

J. A. WORCESTER, JR.,
159 South St.,
Middletown, N. Y.

"Foreigns" Roll In on 16-Tube Receiver

(Continued from page 734)

cycles for the long waves. This affords an accurate means of checking the station to which you are listening. It is only necessary to refer to the station list appearing in SHORT WAVE CRAFT magazine to check the frequency of any station. Tuning is very sharp on this receiver and it should be mentioned here that the operator should exercise extreme care, because it is a very easy matter to pass over a short-wave station and in this way numerous long distance stations will be missed and many fine programs and "DX" records will be lost.

Now the Tetradyne!

(Continued from page 717)

A common "aerial" is used for all four coils. Note particularly that there are no solid metallic connections as far as the aerial is concerned, all connections being made capacitively. The common aerial in the Tetradyne is simply a piece of bus-bar wire. Exceedingly short connections from the stator plates of the tuning condensers are made with insulated wire, which are simply wrapped around in a few turns over the bus-bar wire.

It will be found that on the higher wave-bands more turns (approximately four), will be needed. On the lower wave-bands less turns are needed; on the lowest wave-band, that is from 16 to 25 meters, only two turns or thereabouts are needed.

Tetradyne Works Fine in Tests

I chose the capacitive coupling to the aerial, because it does away with any interference between the different tuning circuits, and we now really have the same effect as if we had four separate sets using four individual aerials. In practice, the Tetradyne system works out very well, and the set tunes nicely. I have been able to receive a number of European stations exceedingly well, in some cases with loud-speaker reception on some of the more powerful stations as, for instance, EAQ, Madrid, Spain, and GCS, London.

The thought immediately arises in the reader's mind, "is it possible to work all four bands at the same time?" The answer is yes and no. It all depends. You can switch on all of the "30 tubes and the set will work, but, of course, you must remember that you have only one regeneration control. For that reason, you cannot get as good results by working all bands together as you can if you work each band individually. It is, however, an interesting thought, and it may be possible that some of the stronger stations will come through on all bands, but, of course, if they all do come in at the same moment it won't do you much good, because you won't be able to understand four announcers simultaneously!

(Continued on page 757)

Short Wave Sets

The Best Values . . Dollar for Dollar . . on the Market



ALAN ACE

110 v. A.C.-D.C. S.W. (15 to 200 Meters) 3 Tubes—6F7—43—25Z5
Front Panel Plug-in Coils: Absolutely Quiet Power Built-in Supply Field supply for speaker, phone jack on front panel; completely shielded in metal cabinet.
Complete with 4 coils (15-200 M) less tubes\$16.95
Set Arcturus Tubes 3.95
Complete Kit with Blue Prints 13.95
Broadcast Coll. 1.49

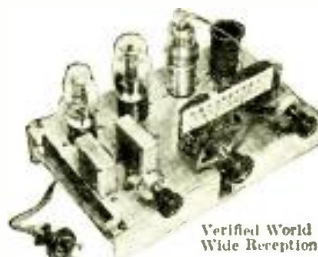

Verified World Wide Reception

ALAN PRIZEWINNER

A.C.-D.C. S.W. (15 to 200 Meters) Completely self powered latest type 77-43 and 25Z5 Tubes. Provision for Head Phones and Speaker.
Complete, less tubes, in rich crackle-finish cabinet. Assembled, wired, tested, ready to plug in.....\$12.95
Complete Kit of parts with prints 10.55



ALAN INTERNATIONAL

110V. A.C.-D.C. S.W. 15-200 meters. 4 tubes: 2-78's, 1-43 and 1-25Z5. Built-in power supply, 4 pairs of plug-in coils. Other specifications same as Alan Ace. Complete, including 4 pr. coils, 15-200 m.....\$24.95
Set Arcturus tubes..... 4.95
Complete Kit with blueprints, 21.95
Pair Broadcast Coils..... 2.75

NEW! The Byrd 2-tube Kit, complete parts, nothing extra to buy. 34 Detector, 33 Pentode
★ Output. Micro-Vernier dial, black crackled finish, hinged top cabinet. Set 4 coils, 15-200 meters. Complete specifications, blueprints, hardware, wire.....\$5.75
Set of matched and guaranteed tubes..... 1.95

ACE and INTERNATIONAL also available for straight A.C. or D.C. (110 or 220 V.), 2 and 6 V. battery operation.
Write Today for Full Particulars.

ALAN RADIO CORP.

Specialists in Short Wave Receivers
83 Cortlandt St. Dept. S4 New York City

SARGENT 9-33 ALL-WAVE RECEIVER

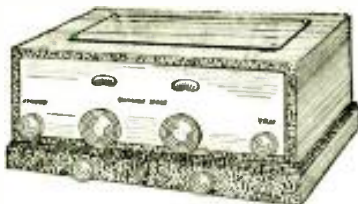

Sargent DX Ranger



Look At These Features:
Wavelength Range 15-550 Meters
Double Shift I.F. System
Sargent Band Spreader, all waves
Large Tuning Knobs
Antenna Trimmer
Tap switch for changing Wave Bands
Separate C.W. Oscillator
Headphone Jack
Tone Control
Push-pull 2A5s in output stage
Rugged, all-steel construction
Polished aluminum panel
Complete Isolation, all R.F. circuits
Single-Signal selectivity
Exceptionally low noise level
No "Frequency Creep"
Self-contained Power Pack
Straight Antenna or Doublet

Send Stamp for Descriptive Circular.
Tubes and Speaker extra. Requires dynamic speaker 1700 or 2500 ohm field wired for push-pull 2A5s, and the following tubes: 1-80, 1-56, 1-58, 1-2A7, 2-2A5s, 3-57s IMMEDIATE DELIVERY—ORDER YOURS TODAY.
AMATEUR NET PRICE \$69.50

A high grade, 2-tube regenerative receiver built for the quality buyer and the advanced amateur. For A.C. uses one 57, one 2A5, for D.C. one 77, one 41 tube. Same band spread system as on the Sargent 9-33. Smooth, "non-squawk" regeneration control. High quality, illuminated tuning dials. Humless, 15 200 meter plug-in coils included, broadcast coil 75c extra, amateur net price. Every U. S. district on 75 meter phone, and foreign broadcasts heard from San Francisco.

Sold as a kit, with chassis plated, drilled and stamped, panel finished in beautiful crystal-line lacquer, complete instructions and blueprints for assembly and wiring. All screws, hardware, everything you need is furnished.
DX Ranger Kit..... **\$12.50**
Amateur Net Price.....
DX Ranger, assembled, wired and tested, Amateur Net Price..... **\$15.75**
DX Ranger Power Pack, wired, ready for use, 250 volts, 50 mls. **\$7.50**
Amateur Net Price.....
Immediate Delivery—Order Yours Today
DEALERS—WRITE

E. M. SARGENT CO.

Sold by Dealers Everywhere 2085 Broadway, Oakland, Calif.



The Breakers

ATLANTIC CITY, NEW JERSEY

On the Boardwalk

SITUATED DIRECTLY ON THE OCEANFRONT AND CONVENIENT TO ALL PIERS AND AMUSEMENTS



\$6 WITH MEALS *Daily* WITHOUT MEALS **\$3**
PRIVATE BATH *Per Person* PRIVATE BATH

Hot and Cold Sea Water in all Baths

EXCELLENT FOOD GARAGE ATTACHED

NOW! The Most Complete and Up-to-Date Popular Priced Line of S.-W. Coils.

Check these Features:

1. Most efficient Wire Spacing
2. Colored Grip Rim for Convenience
3. Each Coil Precision Wound
4. Anchored Windings for Permanence
5. Precision Molded for Rigidity
6. Silk Bank Windings on B.C. Coils
7. Plated Wire for Higher Frequencies
8. Adaptable to Selector Mountings.

New! 705SWB Band Spread Coils with adjustable band setting condenser mounted on top of each coil. Available for 20, 40, 80 and 160 meter Amateur Bands, and 19, 25, 34 and 49 meter R.C. bands when used with usual 140 or 150 mfd. tuning condenser. Last price \$1.00 per coil.

New! 705SWS Regular S.W. Coils, 10-200 meters. Most efficient space windings with plated wire for the higher frequency coils to insure lowest losses possible. Interchangeable with Band Spread coils above when used in a UY socket.

705SWS set of Four S.W. Coils.

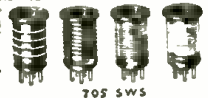

List price \$2.50 per set.

705 SWS

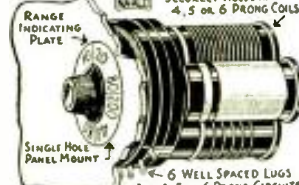

New No. 700 S.W. Coil Selector Unit instantly swings any coil into circuit by turning knob. All 4, 5 and 6 prong coils are rigidly held by the specially constructed sockets without adjustments of any kind.

Knob and indicator on face of panel show what coil is in circuit. Simple - compact - rugged - electrically efficient. Don't fail to use it in sets you are building and new equipment you are designing.

No. 700 COIL SELECTOR UNIT without coils. List Price \$3.50



New No. 450 50-watt Socket with Triple-Lamination Dual Wipe Contact. Molded of best synthetic MAKALOT for low losses. Both solder and binding post terminals. A real heavy duty transmitter socket. List \$1.00.

New No. 92 Large-Size Deluxe Insulated Tube Cap Lead for 866, 872, etc. transmitting tubes. Makes firm contact yet is easily removed without danger of loosening tube cap.

No. 92 Large-Size Tube Cap Lead. List price 35c

Precision wound coils with the convenient gripping-prong for easy insertion and removal from socket. The famous set of four precision wound S-W coils as specified for dozens of receivers described in "S-W Craft". 10-200 meters with .00011 mfd. condenser. Coils have UX bases.



704SWS List price \$2.00 set



704BCS Set of two coils to cover 100 to 550 meters amateur, police and broadcast bands with .00011 mfd. condenser. Precision and bank wound with silk insulation for maximum efficiency. Use the 704BCS to extend the tuning range of any S-W receiver using the 704SWS coils. Coils have UX bases. List price \$1.50 set.



New! 706SWS Set of four six-prong coils with 1 1/4 in. dia. x 2 in. whirling space. Red, Yellow, Green or Blue. Secondaries precision matched with 704SWS sets for perfect tracking. 10-200 meters with .00011 mfd. condenser. Uses standard six-contact tube socket. List price \$3.50 set.

706SWS



706BCS Set of two coils to cover 100 to 550 meters amateur, police and broadcast with .00011 mfd. condenser. Precision and bank wound with silk insulated wire for maximum efficiency. Use the 706BCS to extend the tuning range of any S-W receiver using the 706SWS coils. Coils have regular six prong bases. List price \$2.00 set.



Genuine Makalot Coil Forms with color-coded easy-grip ring. 1 1/4 in. dia. x 2 in. whirling space. Red, Yellow, Green or Blue. 705-4-pin coil form. List 25c
705-5-pin coil form. List 25c
706-6-pin coil form. List 30c

HERE'S THE DATA YOU WANT
Send two 3c stamps for NEW CATALOG-DATA BOOKLET showing socket diagrams of over 265 different tubes, analyzer rewiring data, new tube replacement data, sockets of all kinds, coils, forms, adapters, kits, diagrams for rewiring tube checkers, etc.

ALDEN PRODUCTS CO.
Dept. SW 4
BROCKTON, MASS.
715 Center St.



The tube line-up of the set is as follows: A 6D6 is used as a tuned radio frequency amplifier, ahead of the first detector. The use of a tuned R.F. stage is a decided advantage over coupling the antenna directly to the first detector, in that it reduces image response to a minimum and gives that additional gain necessary when extremely weak signals are encountered.

Two stages of high-gain intermediate frequency amplification are used. Resistor and condenser isolation or "decoupling" is used wherever possible, to reduce reaction between the two stages to a minimum; consequently we have a much lower tube noise-level. A 6B7 is used as the second detector and here provisions are made for feeding a phonograph pickup into the pentode section of this tube.

The audio amplifier section of this 16-tube receiver is very elaborate and capable of reproducing faithfully the strongest as well as the weakest signal. There are three stages; one 37 first audio and two type 37's in push-pull which are in turn coupled to four type 45's in a push-pull "parallel" arrangement. Needless to say this audio amplifier makes the large-size dynamic speaker accompanying the receiver fairly dance around the table.—GEORGE W. SHUART, W2AMN.

5-Meter Transmitter-Receiver

(Continued from page 729)

tion in W9FQU's station, the antenna posts are connected directly to the regular 75 meter fundamental Zep antenna, which also gives good results.

Parts List Transmitter-Receiver

- Receiver**
- L1 5 turns No. 14 wire space wound 1 1/2 inch diameter.
 - L2 4 turns No. 14 wire space wound 1 1/2 inch diameter.
 - L3 Interruption frequency oscillator: primary or grid coil 1,400 turns; secondary or plate coil 500 turns honeycomb type of windings.
 - L4
 - VT1 type 30 tube, R.C.A. Radiotron (Aero.)
 - VT2 type 31 tube, R.C.A. Radiotron (Aero.)
 - VT3 type 49 tube, R.C.A. Radiotron (Aero.)
 - C1 .000035 mf. Hammarlund midget receiving variable condenser.
 - C2 .0005 mf. fixed condenser.
 - C3 .002 mf. fixed condenser.
 - C4 .01 fixed condenser.
 - C5 .002 mf. fixed condenser.
 - C6 .00005 mf. Pilot midget variable condenser.
 - R1 1 megohm 1 watt resistor Lynch.
 - R2 30 ohm fixed resistor.
 - AT audio transformer.
 - OT output transformer.
 - VC 50,000 ohm volume control with "on-off" switch.
 - RF 50 turns No. 30 D.S.C. wire close wound on 3/8" rubber rod.

Transmitter

- L5 Antenna coils, each 1 turn No. 14 wire 1" diameter, 1/4" spacing.
- L6 Plate tank coil, 5 turns No. 14 wire 1" diameter, 1/4" spacing CT.
- L7 Grid coil 11 turns No. 14 wire 1/2" diameter space wound CT.
- C7 Plate tank tuning condenser, Hammarlund .000035 mf. each section.
- R3 15 ohm fixed resistor.
- R4 100,000 ohm 1-watt grid leak Lynch.

Modulator and Speech Amplifier

- MT Acme single button microphone transformer.
- IF Class B input transformer, for type 49 tubes
- OT2 class B output transformer, for type 49 tubes and 5,000 ohm load.
- MA C-100 D.C. milliammeter.
- C7 1 mf. Aerovox fixed bypass condenser.
- C8 .002 mf. Sangamo fixed condenser.
- SW Off-on switch.

DATAPRINTS

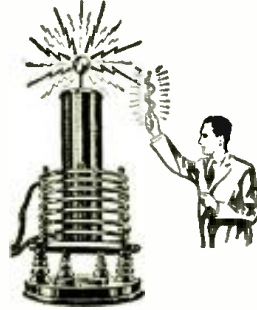

Just the Technical Information You Need To Build Electrical Apparatus

Dataprint containing data for constructing this 3 ft. spark Oudin-Tesla coil. Requires 1 K.W. 20,000 volt transformer as "exciter". See list below. Includes condenser data. \$.75

OTHER "DATAPRINTS" TESLA OR OUDIN COILS

- 36 inch spark, data for building, including condenser data.....\$0.75
- 8 inch spark, data for building, including condenser data; requires 1/2 K.W. 15,000 volt transformer; see list below..... 0.75
- Violetta type, high frequency coil data; 110 volt A.C. or D.C. type; 1" spark; used for "violet ray" treatments and "Experiments"..... 0.50
- How to operate Oudin coil from a vacuum tube oscillator..... 0.50
- 3 inch spark Tesla coil; operates on Ford ignition coil..... 0.50
- 3 inch spark Oudin coil; 110 volt A.C. "Klek-Cole"..... 0.50

TRANSFORMER DATA

- Any size, 200 to 5,000 watts. 41 primary and 1 secondary voltage data supplied—specify watts and voltage desired.....\$0.50
- 1 k.w. 20,000-volt transformer data, 110-volt, 60-cycle primary. Suitable for operating 3 ft. Oudin coil..... 0.50
- 1/2 k.w. 15,000-volt transformer data, 110-volt, 60-cycle primary. Suitable for operating 8-inch Oudin coil..... 0.50
- Electric Welding Transformer (State secondary voltage)..... 0.50
- Induction Coils—1 to 12 inch spark data..... 0.50

MAGNET COIL DATA

- Powerful battery electro-magnet; lifts 40 lbs.....\$0.50
- 110 Volt D.C. magnet to lift 25 lbs..... 0.50
- 110 Volt D.C. 300 lb., lift electromagnet..... 0.50
- 110 Volt D.C. solenoid; lifts 2 lb. through 1 in. 0.50
- 110 Volt D.C. solenoid; lifts 6 lb. through 1 in. 0.50
- 12 Volt D.C. solenoid, lifts 2 lb. through 1 in. 0.50
- A. C. Solenoid, powerful, 110-volt, 60-cycle..... 0.50
- MOTOR—1 1/2 H.P., 110 volt A.C., 60 cycle (suitable for driving 12" fan or light apparatus), constructional data..... 0.50
- 1,200 cycle synchronous motor..... 0.50
- 60 cycle synchronous motor..... 0.50

TELEPHONE — Records Voice or "Code" signals on steel wire by magnetism. Code can be recorded "fast" and translated "slow." Construction data (special).....\$0.50

CLOCKS—Electric chime ringer. How to make one to fit on any ordinary clock.....\$0.50

MISCELLANEOUS DATAPRINTS

- Electric Ice Skates—How to make.....\$0.50
- How to Thaw Pipes by Electricity (including 2 K.W. 110 vs. to 18 st. transformer data) 0.50
- 20 motor circuits—hook-ups..... 0.35
- 20 practical telephone hook-ups..... 0.35
- Treasure Locator..... 0.50
- 100 mechanical movements for inventors..... 0.50
- Polarized Relay—Ultra Sensitive..... 0.50
- Electro-medical coil (shocking roll)..... 0.50
- Water-Wheels—How to Build and Light your house..... 0.50
- Model Ship plans..... 0.50
- Public Address System..... 0.50

20 "Electrical Tricks" for LODGES and PARTIES.....\$0.50

How to Fry Eggs on Cake of Ice Electrically.....\$0.50
"Rewinding" Small Motor Armatures..... 0.50

Other DATAPRINTS on—Centrifugal Pump for Small Fountains, etc.; Model Electric Train—will carry child; Compressed Air power plant for model planes, etc. Write for prices.

(20% Discount on all orders for \$3.00 or more. No C.O.D.)

The DATAPRINT COMPANY
Lock Box 322
RAMSEY, N. J.

New 

**BIRNBACH Antenna
TRANSPOSITION BLOCK**

Increases efficiency of doublet antennas. Strong, highly-glazed ceramic. Rounded edges protect wire. Hooks prevent slipping. No twisting of line. Write Dept. SW-4 for complete details of modern short wave antenna accessories.

BIRNBACH RADIO CO., INC.
145 Hudson St., New York City

SHORT WAVE PARTS

Thorndarson 30 Hy. Chokes, 125 Mills.—limited supply.69c
OCTOCOILS, 4 prong, 16 to 200 meters, 4 coils. \$1.45
Na-Aid type 7048WS Coils—set of 4..... 1.18
Na-Aid type 7065WS Coils—set of 4..... 2.05
Johnson Transposition Porcelain Insulators..... each .09
National S.W. Receivers: FB-7A. \$34.20; FBXA.47.70
National SW-3 S.W. Receivers—A.C. or D.C. models..... 17.70
Bruno Velocity Microphone Kits..... 5.88
McMurdo-Silver Model 5B S.W. Receiver, complete with speaker..... 59.50
Victor ABC Power Transformer, for Model RE-32, etc..... 1.89
REALIGNER Radio Tubes—all types—6 months guarantee—50% off.
Hammarlund Parts in stock—40% and 2% off.
Write for LOW prices on Power Transformers. Inputs. Outputs, Chokes, Filament and Plate Transf. Shield Cans—black shrivel finish and Cadmium Plated Blank Chassis—all sizes—write for prices.
Free bulletin. 20% deposit with all C.O.D. orders. Remit by M.O. Include postage.

MAURICE SCHWARTZ & SON
710-712 Broadway, Schenectady, N. Y.

Practical Radio Engineering

An opportunity for RADIO MEN to enlarge their scope of training

Whether elementary radio principles or advanced subjects, sound applications or practical radio engineering, RCA Institutes is prepared to give you the instruction you need.



Resident schools New York and Chicago with modern standard equipment

Extension Courses for Home Study under convenient "no obligation" plan. Illustrated Catalog on Request

R. C. A. INSTITUTES, Inc., Dept. SW-4
75 Varick St., New York—1154 Merchandise Mart, Chicago

SERVICE MEN!
Increase Your Earnings
Up to \$30-\$50 Weekly

Our Proven, Tested Plan Tells How. Write for Complete Details TODAY!

INSULINE CORP. OF AMERICA,
23-25 Park Place, Dept. W-44, New York, N. Y.

METAL-WORKING LATHE..

Precision equipment for the small shop. New designs and manufacturing processes make this amazing bargain possible. Complete metal working lathe with compound slide-rest, combination face-plate and independent chuck and tail center. 14" swing, 24" length, 20 lbs. Send post card for catalogue or save time and send \$1.00. Balance plus express C.O.D. Lathe for wood-turning alone. \$4. Arrangements for milling, grinding, sanding, saw-table, etc. available at low prices.

American Machine & Tool Co., Dept. F-3, 200 Broadway, New York

 **\$7.50 COMPLETE**

*I'm the Pretzel Bender
... I'll see you on*

PAGE 743 

Now the Tetradyne!

(Continued from page 755)

One of the most interesting uses I found for this set is to convince some of the skeptics what short waves really can do. After you have calibrated the set to four of the best stations on the four different wave-bands, keep the dials in this position. Then ask your friend to sit down and listen. You should have two sets of head receivers so that you can listen at the same time. Then by merely flipping one switch to another, and simply adjusting the regeneration control, you can bring in four different countries at the throw of a switch; always providing, of course, that the stations are on the air! On the first band you can thus get Madrid, on the second band Germany, on the third band England and on the fourth band South America, etc.

Construction

As far as the construction of the set is concerned, I need not say much about this. It is all more or less standard, and nothing particularly new appears here. The pictorial layout, as well as the schematic diagram shows this clearly. The only precaution I would mention is to keep all connections as short as possible, particularly those going from the plug-in coils to the condensers, which are the vital ones. Naturally, the connections going to the tubes must also be short. By following the pictorial layout diagram, I believe I need not add much further as anyone who has built a short-wave set before will have little trouble in duplicating the set.

I have found the 2-volt Air Cell Battery to work well as a source of filament voltage with this set. The "B" voltage should be 135.

The parts list and diagrams give all the values that are required.

I shall be glad to hear from those who have constructed the set. If it meets with general approval, I will present several more of the Tetradyne series in other variations, with different tubes, electrified for 110-volt operation, etc.

Na-aid Plug-in Coil Data

Meters Wave-length	Grid coil turns	Tickler turns	Distance between 2 coils
200-30	52 T. No. 28 En. Wound 32 T. per inch	19 T. No. 30 En. Close wound (C.W.)	1/4"
80-40	23 T. No. 28 En. Wound 16 T. per inch	11 T. No. 30 En. C. W.	1/4"
40-20	11 T. No. 28 En. 3-32" between turns	8 T. No. 30 En. C. W.	1/4"
20-10	5 T. No. 28 En. 3-16" between turns	7 T. No. 30 En. C. W.	1/4"

Collform—2 1/4" long by 1 1/4" dia. 4-pin base.

Parts List for "TETRADYNE"

- 4 140 mmf. tuning condensers, National (Hammarlund).
- 1 Set of 4 plug-in coils, Alden (Gen-Win).
- 4 4-prong Isolantite sockets, National (Hammarlund).
- 1 5-prong socket, National (Hammarlund).
- 4 4-prong sockets, National (Hammarlund).
- 4 .0001 mf. mica condensers.
- 4 5 meghom grid leaks, 1/2 watt, Lynch (I.R.C.).
- 1 25,000 ohm 1/2 watt resistor, Lynch (I.R.C.).
- 1 1 meg. 1/2 watt resistor, Lynch (I.R.C.).
- 1 50,000 ohm variable potentiometer, with switch (Acratest).
- 4 filament switches.
- 1 .00025 mf. mica condenser.
- 1 .002 mf. mica condenser.
- 1 .5 mf. bypass condenser.
- 1 2.5 to 5 mh. R.F. choke, National (Hammarlund).
- 4 National 3-inch velvet-vernier dials.
- 1 14" x 7" aluminum panel (Blan).
- 4 UX 230 tubes RCA Radiotron (Arco).
- 1 UY 233 RCA Radiotron (Arco).
- 1 Antenna ground terminal strip.
- 1 Phone terminal strip.



No ONE can yet say how far-reaching will be the effect of radio on modern living and business—but every one is agreed the industry is still in its infancy . . . that its possibilities are unlimited!

This is why the wisest counselors are advising young men to acquire the fundamentals of radio . . . to prepare themselves for the opportunities ahead. The future is exceedingly bright.

Thousands are finding exactly what they need in the International Correspondence Schools' Radio Course. So can you! Prepared by experts, and frequently revised by them, this course has the enthusiastic approval of the industry.

There is a consistent demand for radio mechanics, assemblers, testers, inspectors, draftsmen, service men, installers and salesmen; also, for operators and attendants on board ship and at commercial radio stations, government police stations and aviation stations. The field of opportunity is unlimited. Let us send you complete information—absolutely free. Use the coupon. Mail it today—Radio beckons you.

INTERNATIONAL CORRESPONDENCE SCHOOLS

"The Universal University"
BOX 2879B SCRANTON, PENNA.

Without cost or obligation, please send me a copy of your booklet, "Who Wins and Why," and full particulars about the subject before which I have marked X:

RADIO OPERATING
 RADIO SERVICING
 ELECTRICAL ENGINEER

Electric Wiring
 Electric Lighting
 Welding, Electric and Gas
 Telegraph Engineer
 Telephone Work
 Mechanical Engineer
 Mechanical Draftsman

Machinist
 Gas Engines
 Diesel Engines
 Aviation Engines
 Civil Engineer
 Refrigeration

Name.....
Age.....
Address.....
City..... State.....
Occupation.....

If you reside in Canada, send this coupon to the International Correspondence Schools Canadian, Limited, Montreal, Canada.

GET ACQUAINTED via Short Waves MR. SHORT WAVE LISTENER



The Twinplex One Tube "Double-Action" Receiver

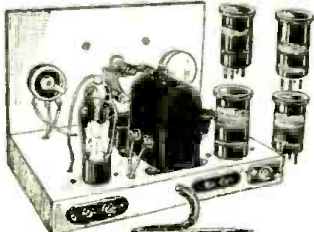

SPECIFICATIONS

- No. 2115. Twinplex 1 Tube Short Wave Receiver. Wire 2, but less tubes and accessories. Ship. wt. 9 lbs. **YOUR PRICE \$9.48**
- No. 2116. Twinplex 1 Tube Short Wave Receiver in Kit Form Including Instructions. Ship. wt. 10 lbs. **YOUR PRICE \$8.48**
- No. 2117. ACCESSORIES ONLY—FOR A. C. OPERATION—Including 1 special Hum-Free A. C. Power pack, 1-80 Rectifier tube, 1-53 Tube and one set of matched head-phones. **YOUR PRICE \$10.34**
- No. 2118. ACCESSORIES ONLY—FOR BATTERY OPERATION—Including 1-53 Tube, 3-45 volt B Batteries, 4 No. 6 Dry Cells (arranged in series—parallel) and 1 set of matched head-phones. Ship. wt. 15 lbs. **YOUR PRICE \$6.24**

The OSCILLODYNE 1-Tube Wonder Set ABSOLUTELY FOOL-PROOF

Simple directions and blueprints show you how to build and operate the set for best results. It may be used either on A.C. or with batteries. If A.C. is employed, a type 227 tube is used in conjunction with a suitable A.C. power pack (such as the one listed on the opposite page. If batteries are employed, a 227 tube should be used in conjunction with either a storage battery or four No. 6 dry cells and two 45 volt B batteries. If you have never operated a short-wave set, this is the one with which to start! It is a set which will convince you that foreign stations CAN be tuned in whenever they are on the air. Its circuit which is of the regenerative variety, acts like a super-regenerative set although it does not belong in that class. Its sensitivity is tremendous. Here, then, is a set which brings in stations thousands of miles away; a set which frequently brings in Australia, loud enough to rattle your phones, and with power to spare; a set which, if you do not wish extreme distance, will bring in stations several thousand miles away without aerial or ground.

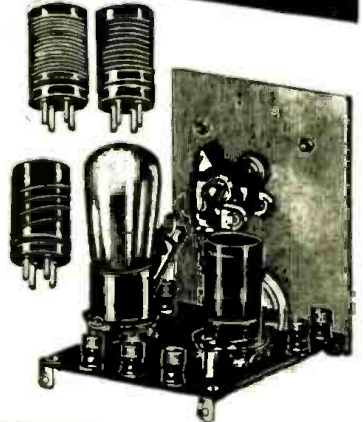

SPECIFICATIONS

- The set is exactly as illustrated here, size of aluminum panel is 6" high by 4 1/2" wide, base 3 1/2" long by 4 1/4" wide. List of materials used:
- No. 2146. Official One-Tube Wonder Set, completely wired and tested as per above specifications. **YOUR PRICE \$7.20**
- No. 2147. Official One-Tube Wonder Set, but not wired, with blueprint connections and instructions for operation, complete shipping weight 3 lbs. **YOUR PRICE \$6.35**
- No. 2148. COMPLETE ACCESSORIES, including the following: one 6 month guaranteed Neontron No. 237 tube; one set No. 1678 Brandes matched headphones; four No. 6 Standard dry cells; two standard 45-volt "B" batteries, complete shipping weight 22 lbs. **YOUR PRICE \$5.50**

THE WORLD FAMOUS DOERLE RECEIVERS

Both A. C. and 2-Volt Battery Sets

If you are a constant reader of this magazine, you have probably noticed our consistent advertisements of these famous Doerle receivers. It is no longer necessary to describe them in minute detail. The tremendous sale of these receivers is in itself a fine tribute to their quality and performance.

Two different styles are available, each style having two models. THE A. C. TYPE is designed for metropolitan areas where electric service is available. It is obtainable in 2 and 3-tube models, each requiring a power pack such as the one illustrated on the opposite page. THE 2 VOLT BATTERY TYPES were designed particularly for rural districts. They, too, are available in 2 and 3-tube models. There is no question but what these receivers are comparable to, and in many instances even surpass many of the more expensive short wave receivers. Thousands of testimonials in our files laud these sets to the skies. Only the finest parts go into their construction. Stations which you have never heard before will come in clearly and regularly. Yet withal they are extremely simple and therefore absolutely foolproof. All 2-tube models measure 9"x6"x6 1/4"; 3-tube models measure 10 1/2"x7"x8".



Rear View of Battery 2-Tube Set

Battery Doerle Sets

- No. 2140. TWO TUBE 12,500 MILE 2-VOLT DOERLE SHORT WAVE RECEIVER, completely wired and tested. Shipping wt. 5 lbs. **YOUR PRICE \$9.88**
- No. 2141. Same as above in kit form, with blueprint connections and instructions. Shipping wt. 5 lbs. **YOUR PRICE \$8.68**
- No. 2142. COMPLETE ACCESSORIES, including 2 No. 230 tubes; one set of Headphones; 2 No. 6 dry cells; 2 standard 45-volt "B" batteries complete. Shipping weight, 22 lbs. **YOUR PRICE \$5.38**
- No. 2143. THREE TUBE 2-VOLT DOERLE SET, completely wired, ready for use. **YOUR PRICE \$12.84**
- No. 2144. THREE TUBE 2-VOLT DOERLE SET IN KIT FORM, with blueprint connections and instructions. Shipping wt. 7 lbs. **YOUR PRICE \$11.48**
- No. 2145. COMPLETE ACCESSORIES, including 2 No. 230 tubes; and one type 34, one set of Headphones; 2 No. 6 dry cells; 3 standard 45-volt "B" batteries; 1 B. B. L. 9 inch Magnetic Loudspeaker. Shipping weight, 32 lbs. **YOUR PRICE \$11.48**

Electrified Doerle Sets

- No. 2174. Electrified 2 Tube 12,500 Mile Doerle Receiver, completely wired and tested, less tubes. Ship. wt. 5 lbs. **YOUR PRICE \$10.44**
- No. 2175. Same as above in kit form, less tubes, but including blueprints and instructions. Ship. wt. 5 lbs. **YOUR PRICE \$9.24**
- No. 2176. Complete set of tubes for above; either one—27 and one—50 for A. C. operation, or one—77 and one—37 for battery operation. **YOUR PRICE \$1.59**
- No. 2177. Electrified 3 Tube Doerle Signal Gripper, completely wired and tested; less tubes. Shipping wt. 7 lbs. **YOUR PRICE \$15.29**
- No. 2178. Same as above in kit form, including blueprints and instructions; less tubes. Ship. wt. 7 lbs. **YOUR PRICE \$13.74**
- No. 2179. Complete set of tubes; either one—58 and one—50 for A. C. operation or one—78 one—77 and one—37 for battery operation. **YOUR PRICE \$2.49**

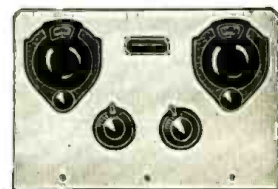

Front View of all 3-Tube Doerle Receivers

FREE! BOOKS

YOUR CHOICE of either one of books illustrated herewith—FREE OF CHARGE—with the purchase of any of the short-wave receivers listed on these pages.

Book No. 866 explains the ways and means of obtaining an amateur transmitting license. Book 830 is a comprehensive compilation of the most prominent short-wave receiver circuits published during a period of two years.



No. 830



No. 866

RADIO TRADING COMPANY, 100A Park Place, New York City

Come On! LET'S FRATERNIZE Fellows! MR. SHORT WAVE AMATEUR—Meet

**"R. T."
AMATEUR C. W. PUSH-
PULL TRANSMITTER
15 to 30 WATTS
ALL AMATEUR BANDS**

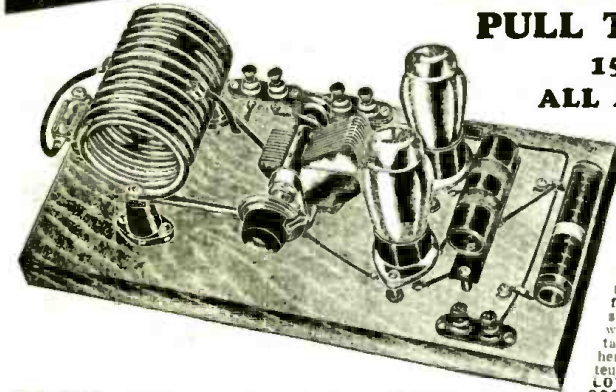

It's Fool Proof—Because It's Simple

This transmitter with a power output of anywhere from 10 to 30 watts (depending on the type of tubes employed) is a real globe girder. Some people have the impression that a transmitter with a power output of, let's say, 10 watts, will transmit only several miles, and no further. This is not the case, for in short wave transmission, location and weather conditions constitute important factors. The transmitter described here will transmit to the far corners of the earth. A GOOD LOCATION IS, PRACTICALLY, A LOW POWER TRANSMITTER IN A POOR LOCATION.

SPEAKING, MORE "POWERFUL" THAN A HIGH POWER TRANSMITTER. The transmitter illustrated is essentially a low powered, low cost, outfit for the beginner. It is not, however, confined to the beginner. Many dyed-in-the-wool amateurs have one or more of these transmitters handy as auxiliaries. Two type 45 tubes are used as oscillators. These tubes are used because of their low cost and because, in actual operation, they have practically the same output as the type 210 tubes, at one-third their cost. The circuit is of the type using fixed-tuned grid, tuned plate.

All grid coils are wound on one inch bakelite tubing with fine wire so that their natural frequency response is near the center of each amateur band. The frequency peaks of these coils are rather broad which means that THE ENTIRE BAND OF ANY GIVEN COIL CAN BE COVERED WITH THE PLATE CIRCUIT, WITHOUT THE TWO CIRCUITS GETTING OUT OF RESONANCE. These grid coils are of the 3-prong plug-in type. The plate coils are of copper tubing and are mounted on stand-off insulators. They are easily interchangeable for the various bands.

The construction of this transmitter is the simplest ever devised. From the diagram printed in the editorial section of this catalog it can be seen that no grid or filament by-pass condensers are used and that the usual R.F. choke has been omitted from the plate circuit. No benefit was derived from their employment and hence they were not used. The method of coupling the antenna to the output circuit is unique, and is a desirable feature. The antenna suggested for use with this transmitter is the single-wire-feed Heriz. THE TRANSMITTER IS SUPPLIED WITH A SET OF 160 METER COILS. Coil sets to cover the other amateur bands can be had at the addition prices shown below.

Popular 1-TUBE "PUSH-PULL" TRANSMITTER

for
10 METERS

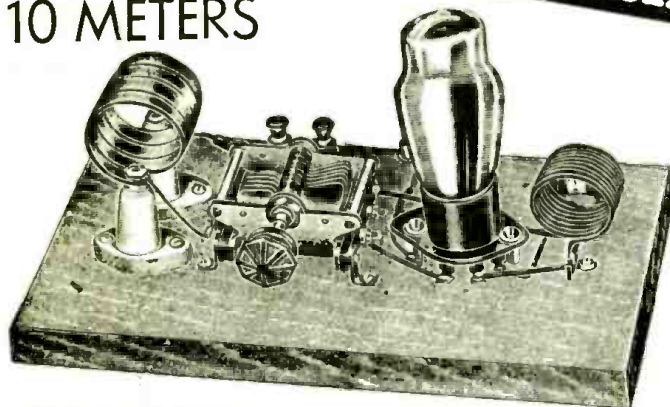

EXCELLENT FOR PHONE WORK

A single button microphone can be inserted in series with the grid return lead (using no transformer,) thereby obtaining from 50 to 75% modulation.

Order From These Pages

Send money order or certified check. C. O. D. only, if 20% remittance accompanies all orders. Order NOW—TODAY.

FREE 108 Page Radio and Short Wave Treatise, 1934 Edition. Send 4c postage. Treatise by Return Mail.



POWER SUPPLY

The power supply to operate this transmitter delivers 400 volts at 150 milliamperes for the plates of the tubes and 2.5 volts for the filaments. A type 83 mercury vapor rectifier is used because of its low voltage drop which permits excellent regulation. The filter consists of a 30 Henry iron-core choke with two 2 mf. 1000 volt condensers on either side. A suitable size bleeder resistor is connected across the output filter to further aid in regulation by suppressing the high voltage peaks when there is no load on the power pack as is the case when the key is in the "off" position. Ship. wt., 8 lbs., for transmitter and 18 lbs. for power pack.

- No. 2121 "R.T." Push-Pull Transmitter, complete with 160 meter coils, but less tubes. **YOUR PRICE \$5.94**
- No. 2122 Power Pack for R.T. Transmitter, less tube. **YOUR PRICE 7.98**
- No. 2123-A Plug-In Coils for 20 Meter Band. **YOUR PRICE 1.78**
- No. 2123-B Plug-In Coils for 40 Meter Band. **YOUR PRICE 1.78**
- No. 2123-C Plug-In Coils for 80 Meter Band. **YOUR PRICE 1.78**

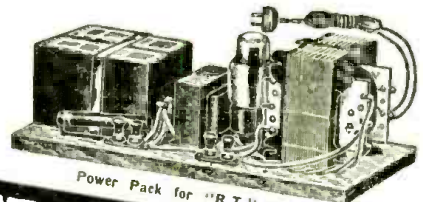

Power Pack for "R.T." Transmitter

Paradoxical as it may sound, this ten meter transmitter EMPLOYS A SINGLE TUBE IN PUSH-PULL ARRANGEMENT. Heretofore the word "push-pull" automatically implied the use of two tubes, yet here we are with a one tube push-pull transmitter.

It is the advent of the new type 53 tube, which makes this feat possible. This tube is actually "TWO" tubes, in one glass envelope. It was designed primarily as a class "B" twin amplifier.

This transmitter is not a high power job, for high power is not necessary on ultra short wave work. When properly coupled to a suitable antenna system such as a single-wire-feed Heriz or the familiar "Zeppelin" antenna, it will, under favorable conditions, go a long way. The circuit is of the fixed-tuned grid, tuned plate type and utilizes a solenoid of solid copper ribbon as the plate coil. All component parts are of the highest possible quality, since R.F. losses in ultra short wave work are fatal.

There are any number of uses to which a compact unit of this type may be placed. For instance it can be used as a master oscillator for multi-stage high frequency transmitters OR two such units may be connected together to produce a complete master oscillator—R.F. amplifier transmitter. Neutralizing condenser must be added when used as an R.F. amplifier. The transmitter requires 2 1/2 volts either A.C. or D.C. for the filament of the 53 tube and anywhere from 180 to 350 volts "B" supply. A key measures 11" long x 6 1/4" wide x 6" high overall. The transmitter on its neat bread-board complete with a set of 10 meter coils. Shipping weight 6 lbs. No. 10-M Versatile 10 Meter Transmitter less Tube. **YOUR PRICE \$4.48**

Special A. C. Short-Wave Power Pack

Everyone knows that an A. C. short-wave set is no better than the supply for short-wave use must be constructed with extreme care. It must be absolutely free from hum or other disturbances caused by insufficient filtering, poor wiring, or faulty equipment.

This unit has a two-section filter circuit, employing two heavy-duty 30 Henry chokes at all. This assures PURE D. C. with practically no ripple at all.

This power pack supplies 250 volts at 50 mills for the filament of the tubes, 22 1/2 volts for the screens, and 2 1/2 volts at 5 amperes for the filament. Furthermore, provisions are made for energizing the field of a dynamic speaker. Any speaker having a field resistance of from 1500 to 2500 ohms may be thus energized. All the component parts of this pack are built into a sturdy, metal base. The pack employs a type 280 full-wave rectifier which is inserted in a socket on top of the base. A convenient on-off switch is mounted on the side. The pack is mid-mount plate with four feet of connecting cord, terminating in a standard male plug. Measures 7 1/2" long x 4" wide x 4 1/4" high overall. **YOUR PRICE \$7.24**

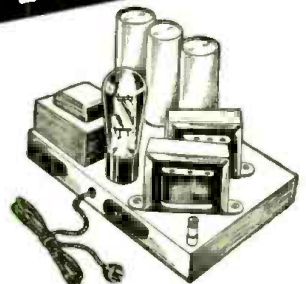

RADIO TRADING COMPANY, 100A Park Place, New York City

Leotone SHORT WAVE A.C.

This new receiver has everything you have ever looked for in a short-wave set. It is newly designed, is compact—a great distance getter—regularly brings in Italy, Spain, Germany, England and many other countries. Know the THRILL of distance—listen in on police calls, air-craft communication. Can be installed in your car or motor boat.



The LEOTONE A.C. Receiver uses the following Arcturus tubes: 58-R.F., 57-detector, 56-1st. A.F., 2A7-2nd. A.F. and 80 Rectifier. Complete Kit with 2 sets of Gen-Win coils (8 coils) and Arcturus Tubes\$18.95
Completely wired and tested with matched kit of Arcturus tubes\$21.95

Special Shielded S. W. Battery Set
Built in same Foundation Kit as above.

Perfect performance assured—this set has a "KICK." Uses the following tubes: 1-30, 1-32, 1-33, 1-34 low current drain tubes. Complete kit of parts with two sets of Gen-Win coils (8 coils) and Arcturus Tubes, \$11.95. Kit completely wired, including Arcturus Tubes, \$14.45.

LEOTONE RADIO CO.

63 DEY STREET NEW YORK, N. Y.

BRUNO

SHORT WAVE COILS



Model "S" coils feature the heavy silvered-ribbon, secondary winding resulting in highest efficiency and minimum losses.
Model "E" coils are used by thousands. Wound with the finest enamel wire.
Both Model "S" and Model "E" coils are wound on ribbed forms 3 5/8" high and 1 1/2" diameter.
Model "S" coils—Silver wound coils (14-200 meters) Set of 4\$2.94
Model "E" coils—Enamel wound (14-200 meters) Set of 4\$1.75
"Junior" coils (14-200 meters) Set of 4.95c ea.

TRY-MO RADIO CO., INC.
85-S Cortlandt St., New York, N. Y.

GET THE NEW "KEYKLIX"



Thousands of amateur radio items, at the lowest prices, are contained in this FREE, 132 pages, Big Book, together with many interesting articles by people well known in amateur radio circles.

AMERICAN SALES COMPANY
Wholesale Radio Distributors
S. W., 44 W. 18th St., N. Y., N. Y.
The Oldest Amateur Supply House, Est. 1919

PATENTS — TRADE MARKS

All inventions submitted held confidential and given personal attention by members of the firm.
Form "Evidence of Conception" and instructions
"How to Establish Your Rights"—Free
LANCASTER, ALLWINE & ROMMEL
PATENT LAW OFFICES
435 Bowen Bldg. Washington, D. C.

Short Wave Scouts

(Continued from page 733)

Station List

These stations received after Jan. 19, 1934, and before Feb. 1, 1934,

Station	Location	Frequency
W9XF	Chicago, Ill.	6100 kc.
W8XAL	Cincinnati, O.	6060 kc.

Not Verified

GCW	Rugby, England	9790 kc.
HC2RL	Quayaquil, Ecuador	6668 kc.
HAROLD W. HANSEN, Route 5, Box 169, South Omaha, Nebraska.		

Trophy Contest Entry Rules

NOTE that we have amended our rules, and you will find that the rules now read:

Fifty Per Cent Verified and 50 Per Cent Unverified

In other words, if you send in a list of 100 stations, and at the same time you send in 50 verification cards, you will get credit for 100 stations, beginning immediately. This, we believe, should take care of all SHORT WAVE SCOUTS handsomely and give them the benefit of the doubt.

In order to protect everyone, the rules have been amended that a sworn statement before a Notary Public, which only costs a few cents to get, must be sent in at the same time. This is done to protect the honest and conscientious SHORT WAVE SCOUTS from the practical jokers and irresponsible elements who are unfortunately always with us.

It is to be hoped that the amended rules now make it much easier for the would-be entrants.

For the complete article of the Purpose of the SHORT WAVE SCOUTS, we refer to page 393 of the November, 1933, issue.

Here are the rules amended:

You wish to know how you can win this valuable trophy, and here are the simple rules. Be sure to read them carefully. Do not jump at conclusions.

- 1.—A monthly trophy will be awarded to one SHORT WAVE SCOUT only.
- 2.—The purpose of this contest is to advance the art of radio by "logging" as many short-wave commercial phone stations, in a period not exceeding thirty days, as possible by any one contestant.
- 3.—The trophy will be awarded to that SHORT WAVE SCOUT who has logged the greatest number of short-wave stations during one month.
- 4.—In the event of a tie between two or more contestants, each logging the same number of stations, the judges will award a similar trophy to each contestant so trying.
- 5.—Verifications are necessary; these must be sent in with each entry. All cards or verification letters must be sent in at the same time, with a statement by the SHORT WAVE SCOUT, giving the list of stations in typed or written form, with the station calls, wave-lengths, and other valuable information. (See below.) The verification letters and cards will be returned to the SHORT WAVE SCOUT at the end of each monthly contest. (See Jan., 1933, editorial how to obtain verifications.)

6.—Inasmuch as not all stations send out verification letters or verification cards, each contestant is entitled to report not more than 50% of station calls for which no proper verification is submitted. For example, if you should mail a list of 100 stations, and submit 50 verification cards or letters with this list, the Judges would allow the 100 stations, providing such data is given for the 50 unverified stations as to enable an intelligent check to be made by the Judges. In the interest of all SHORT WAVE SCOUTS, however, contestants should try to send in as many verifications as possible. Each list submitted must be sworn to before a Notary Public, as follows:

FREE!

108 Page RADIO and SHORT WAVE TREATISE

Over 100 Hook-Ups More Than 1,500 Illustrations



A Veritable Text Book

NOT JUST ANOTHER CATALOG

This completely revised and enlarged 1931 edition contains 108 solid pages of useful radio information, diagrams, illustrations, radio kinks and real live radio merchandise. It contains more valuable radio information—more real live "meat" than many textbooks on the subject. As usual considerable space has been devoted to the beginner in radio.

PARTIAL LIST OF CONTENTS

Chapter Two of "Fundamental Principles of Radio for the Beginner"—The New Tubes, Their Uses, and Their Fundamental Circuits—How to Make Money with Public Address Systems. How to Install and Maintain Them—How to Revamp Six-Volt Battery Sets to Use Two-Volt Tubes—Prize Winning Kinks and Short Cuts in Radio—How to Build the Famous Twinlex Transmitter—How to Build the Famous Twinlex Short Wave Receiver—How to Construct an Amateur Radio Transmitter—A Most Modern and Complete Tube Chart including Socket Connections for all Tubes—Numerous Free Offers, etc., etc.

WRITE TODAY

Enclose 4 cents for postage. Treatise sent by return mail.

RADIO TRADING CO.

100A Park Place New York City

Short Wave League Members

Here is something that is indispensable for your den or study.

A GLOBE OF THE WORLD WITH MAGNETIC COMPASS

The frame is of metal, the globe is 6 inches in diameter, printed in fifteen colors and can be washed.



With this globe you can log foreign stations. It is substantially made and is a real ornament.

Price prepaid \$1.25

See page 766

With BYRD at the SOUTH POLE

Where dependable communication is so vitally important, perfect radio equipment is imperative. Nearly 100 standard Billey Crystals are with Byrd in the Antarctic... not alone a splendid endorsement of their quality, but proving the certainty of crystal control.

BLILEY CRYSTALS AND HOLDERS

Type	Mc Band	Supplied	Pre-cision	Pur-lished	Price
BCX	1.7, 3.5, 7.0	25 Kc*	0.05%	Unmtd.	\$3.90
BC3	1.7, 3.5, 7	25 Kc*	0.03%	Mtd.	4.95
BC3	1.7, 3.5, 7	5 Kc	0.03%	Mtd.	5.75
BC3	1.7, 3.5, 7	0.5 Kc	0.03%	Mtd.	6.85
BC5	100Kc	Exact	0.05%**	Mtd.	9.50
BC2	1.7-3.5Mc, or 7Mc holder for BCX				1.50
BC6	1.7, 3.5 or 7Mc holder-oven for BCX				7.50
SSF	465, 500 or 525Kc S.S. Qtz filter, Mtd.				5.90

*Or your choice from distributor's stock
**Adjustment by purchaser will greatly reduce this
Billey Crystals are sold at all progressive distributors of amateur equipment, and manufactured under NRA. Get our 1934 illustrated folder, and large 3-color frequency chart from your distributor... or write us direct.

BLILEY PIEZO-ELECTRIC CO.
236 Union Station Bldg. Erie, Pa.

MILES SOCKET MIKE!

Pat. Pend. Developed by MILES a microphone plugging into light socket which reproduces speech and music in your own radio from any place in building without wires. Clear, powerful instantaneous reception at your disposal anytime, anywhere. Details on request.

We also repair any make microphone. Quick delivery.

We built over 300 types of Microphones, Amplifiers, Horns, Units and Accessories. We also repair your old equipment.

PUBLIC ADDRESS EQUIPMENT



MILES REPRODUCER CO.

244 W. 23rd St. Dept. S. New York City

ALL-WAVE AIR SCOUT

ONLY SET OF ITS KIND IN THE WORLD

Designed by H. G. CISIN, Inventor of the Universal A.C.-D.C. Circuit.



THIS powerful little set brings in all standard broadcast stations and also police calls, amateur calls, foreign stations, code and trans-Atlantic phone conversations. Powered by inexpensive batteries. Available in Kit form. Patented terminal color coding feature eliminates need for wiring diagram. Red is connected to red, black to black, etc., and set is ready to operate. Used by thousands of Boy Scouts. Scout John Stott of Sanford, Me., brought in England, Holland, Germany and South America on this set. Complete Kit with Tube, Postpaid Earphone, Two Coils—nothing else to buy except batteries. **\$5.00**
Assembled, wired and ready to use—\$5.95 postpaid.
SPECIAL OFFER: Valuable data on ALL-WAVE SET sent upon receipt of 10c to cover handling costs.
ALLIED ENGINEERING INSTITUTE
968 PARK PLACE NEW YDRK, N. Y.

The undersigned declares under oath that the stations listed in this list and submitted in the SHORT WAVE SCOUT Contest were received by me during the past thirty days, that the reception was bona fide and was obtained by me without assistance from any outsider, and that I personally listened to the station announcements as given in this list.

7.—This is an international contest in which any reader, no matter where located, can join. It is allowable for SHORT WAVE SCOUTS to list stations in their own countries, if they desire to do so. In other words, SHORT WAVE SCOUTS residing in the United States can log stations in the United States, as well as foreign stations. There will be no discrimination in this respect.

8.—SHORT WAVE SCOUTS are allowed the use of any receiving set, from a one-tube up to one of sixteen tubes, or upwards, if they so desire.

9.—When sending in entries, note the following few simple instructions: Type your list, or write in ink, *pencilled matter is not allowed*. Send verification cards, letters and the list all in one package, either by mail or by express prepaid; *do not split up the package*. Verification cards and letters will be returned, at the end of the contest, to their owners; the expense to be borne by SHORT WAVE CRAFT magazine.

10.—In order to have uniformity of the entries, when writing or typing your list observe the following routine: **USE A SINGLE LINE FOR EACH STATION**; type or write the entries **IN THE FOLLOWING ORDER**: Station call letters; frequency station transmits at; schedule of transmissions, if known (all time should be reduced to Eastern Standard which is five hours behind Greenwich Meridian Time); name of station, city, country; identification signal if any. Sign your name at the bottom of the list and *furthermore state the type of set used by you to receive these stations*.

11.—Don't list amateur transmitters in this contest, *only commercial phone stations*, no CW and no "code" stations.

12.—This contest will close every month for the next twelve months on the first day of the month, by which time all entries must have been received in New York. Entries received after this date will be held over for the next month's contest.

13.—The next contest will close in New York April 1st.

14.—The judges of the contest will be the editors of SHORT WAVE CRAFT, and their findings will be final.

15.—Trophy awards will be made every month at which time the trophy will be sent to the winner. Names of the contesting SCOUTS not winning a trophy will be listed in Honorable Mention each month.

16.—From this contest are excluded all employees and their families of SHORT WAVE CRAFT magazine.

17.—Address all entries to SHORT WAVE SCOUT AWARD, 98 Park Place, New York City.

How to Get Verification Cards

First of all, write the letter neatly, type-written or ink, never in pencil! Give the exact local time of reception, as well as Greenwich meridian time.

Be sure to mention that part of the program which you listen to.

Be sure to thank the station manager for giving you the program and how much pleasure you received by listening to his station.

State in the letter that you enclose an *International Postage Reply Coupon*. Never send cash or stamps. The foreign stations cannot use them. The International Postage Reply Coupon costs 9c. You must buy it at your local Post Office.

Most important is the matter of postage. Letters to Europe, Australia, Asia, Africa and most of the foreign islands go at the rate of 5c, if the letter weighs less than an ounce. If it weighs above this, extra postage must be prepaid.

But few stations will answer your requests, unless the *International Postage Reply Coupon* is used!

HEY!



MUST WE LISTEN TO THAT SHAM-BATTLE?

"Whaddaya mean 'sham-battle'? That's one of London's best orchestras!"

Ed retorted, with snap: "Sounds like a boiler factory to me. Where'd you get the noise-maker, anyway—five and dime?"

"Go away, dope, that 11 tube all-wave radio set cost a couple of centures and it's guaranteed to bring in all the 'foreigners' the way you get locals on your outfit!"

Followed a Bronx cheer. "I'll be thrown out, pronto, if you don't choke on off. It's lousy, now, but it could be made to work."

"Okay, wise guy, I'll ask the question—How can it be fixed up?"

"The gunk who set you up with it probably didn't tell you, but no radio, even if you pay a grand for it, is better than the aerial you hook it to. Even yours would be use if you gave it a chance... now, do we play cards or what?"

"No Radio Can Be Better than its Aerial"

Lynch All-Wave Antenna System Complete Kit (with Instructions) **\$6.50** Less

At Radio and Department Stores; or by mail C.O.D., or postpaid upon receipt of price. Write TODAY for amazing FREE booklet that explains how you can cut out radio noises.

LYNCH MANUFACTURING CO., Inc.
51 VESEY STREET NEW YORK, N. Y.

Makers of Lynch "Noise Reducing" Antenna Systems and Famous Metallized Resistors.

CIRCLE THE GLOBE



You can now circle the Globe with the same set as used by Captain H. L. Hall. The **POSTAL INTERNATIONAL**

TIONAL is a 9-tube, genuine superheterodyne—custom built for the better Short Wave Fan and Amateur. In the first three weeks, Capt. Hall logical every continent on his **POSTAL INTERNATIONAL**.

TUNED R F PRE-SELECTOR

Tuned the **POSTAL** employs a genuine Tuned RF Pre-selector—the new triple drawer coils, including band spread-Electron coupled oscillator—audio beat oscillator, and many other important features too numerous to mention.

Send a 3c stamp immediately for our complete, illustrated booklet and free circuit diagram.

POSTAL RADIO

135-B LIBERTY ST., N. Y. C.



EXPLORE THE HITHERTO UNEXPLORED LONG WAVES USING YOUR OWN SHORT WAVE SET!

The new H. B. Long wave plug-in coil and its two fixed capacitors will enable you to reach from 450 meters to 1610 or 1740 or even up to 2140 meters according to the size tuning condenser you use in your set. Listen to the stiffs on 300 or 715 meters and Radio Compass stations on 800 meters. Airliners on 900 and Beacons on 1,000 meters.

4 prong H. B. Long Wave Coil **\$2.50** and 2 capacitors.....
Please mention make of coil and size of condenser used in your set.

16 Gauge Aluminum Panels

7 x 10...24c 7 x 12...28c 7 x 14...32c
These panels are a special lot at the above prices. Longer and wider at correspondingly low prices. Add postage on 1 lb.

We have no catalog. Please do not ask for one.
BLAN THE RADIO MAN, INC.
177-H Greenwich St. Dept. SW New York, N. Y.

Blank Cartridge Pistol

REVOLVER STYLE

.22 CAL.

MADE IN 3 SIZES



25c
50c
\$1.00

Three new models now out 25c, 50c and \$1.00. Well made and effective. Modelled on pattern of latest type of Revolver. Appearance alone enough to scare a burglar. Takes 22 Cal. Blank Cartridges obtainable everywhere. Great protection against burglars, tramps, dogs. Have it lying around without the danger attached to other revolvers. Fine for 4th July. New Years, for stage work, starting pistol, etc. **SMALL SIZE 4 in.** (long 25c. **MEDIUM SIZE 5 in.** (long 50c. **LARGE SIZE 6 in.** (long \$1.00. **BLANK CARTRIDGES 50c per 100. HOLSTER (Cowboy type) 50c. Shipped by Express only not prepaid. 710 page catalog of other pistols, sporting goods, etc. 10c**

BOYS! THROW YOUR VOICE

Into a trunk, under the bed or anywhere. Lots of fun fooling teacher, policeman or friends. **THE VENTRILO** a little instrument, fits in the mouth out of sight, used with above for Bird Calls, etc. Anyone can use it. **Never fails. A 16-page course on Ventriloquism together with the Ventrilo. All for 10c postpaid.**

Subscribe to our Monthly Magazine

Fun, Magic and Mystery

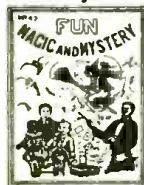

We also publish a monthly magazine of **FUN, MAGIC AND MYSTERY**. Each issue contains a big collection of parlor magic, tricks with cards, fortune-telling, funny readings, amusing experiments, money-making secrets, jokes, riddles, conundrums, parlor amusements, puzzles, problems, science, mechanics, etc. In addition it will list all the latest novelties, tricks, puzzles, etc. Because it is really a magazine and catalog combined, we have fixed the subscription price at **ONLY 10c per year, or 3 years for 25c.** This as you readily see does not even cover our mailing expenses, let alone the cost of getting up the magazine. Try this magazine for one year.

Novelty French Photo Ring

Here is a very great novelty in Rings, that is selling in thousands. It is a nicely made ring, finished in imitation platinum, and set with a large imitation diamond. It looks just like an ordinary ring. But in the shank of the ring is a small microscopic picture almost invisible to the naked eye, yet is magnified to an almost incredible degree and with astonishing clearness. There is quite an assortment of pictures that should suit all tastes. Some are pictures of bathing girl beauties, pretty French Actresses, etc., others are views of places of interest in France, Panama Canal and elsewhere; others show the Lord's Prayer in type, every word of which can be read by persons with normal eyesight. They are interesting without being in any way objectionable. **PRICE 25c, 3 for 65c, or \$2.25 per doz. postpaid. 710 page Catalog 10c.**



MAKE YOUR OWN RADIO RECEIVING SET



Enjoy the concerts, baseball games, market reports, latest news, etc. The copy-righted book **SABIG RADIO SETS** shows how to make your own. **Extensive Radio Sets, the materials for which can be purchased for a mere trifle. Also tells how to build a short-wave Receiver for bringing foreign stations, police calls, ships at sea, etc. ONLY 15c. Postpaid.**

SILENT DEFENDER



Used by police officers, detectives, sheriffs, night watchmen and others as a means of self-protection. **Always ready for instant use. Easily fits the hand, the fingers being grasped in the four holes. Very useful in an emergency. Made of aluminum they are very light, weighing less than 2 ounces. Handy pockets size 25c each, 2 for 45c Postpaid.**

BIG ENTERTAINER



180 Jokes and Riddles, 34 Magic Tricks, 54 Parlor Games, 73 Toasts, 15 Tricks with Cards, 60 Money-making Secrets, 10 Funny Readings, 3 Monologues, 21 Puzzles and Problems, 5 Comic Recitations, Cut-outs for Checkers and Chess, Dominoes, Fox and Geese, 9 Men Morris, Spanish Prison Puzzle, Game of Anagrams, etc. All for 15c Postpaid.

WONDERFUL X-RAY TUBE

A wonderful little instrument producing optical illusions both surprising and startling. With it you can see what is apparently the bones of your fingers; the lead in a lead pencil, the interior opening in a pipe stem, and many other similar illusions. **Price 10c, 3 for 25c.**

HOW TO WIN AT POKER

Written by a card sharper. Tells how to win at draw poker. Explains different varieties of poker such as Night Poker, Stud Poker, Five Card Stud, etc. Shows the methods used by card sharppers and professional gamblers. **12 Cents. This book contains a vast amount of information and may save you from being fleeced by crooked players and gamblers. Price 10c Postpaid. 710 page Novelty Catalog 10c.**

THE FAN DANCE

Who will forget the famous **FAN DANCE** episode of the Century of Progress Exposition in Chicago. Here it is humorously, clearly, presented in vest pocket form. **You flip the pages and HITS AND HITSY TOSY comes to life and whirls through her dance... provoking, not a sly smile, but a wholesome laugh from all. No end of fun and amusement. Spicy, piquant entertainment for all. Pocket size, 2 3 inches. Price 10c ppd. 710 page Novelty Catalog 10c.**

Fortune Telling By Cards

Book shows how to tell fortunes with cards, dice, dominoes, crystal, etc. Tells the meaning and signification of every card. Several different methods explained and fully illustrated. Cramped full from cover to cover with complete information on fortune-telling. **Price 10c Postpaid. Stamps accepted.**

Good Luck RING

Very striking, quaint and uncommon. Oxidized gunmetal finish; skull and crossbones design; two brilliant flash in imitation rubies or emerald inlaid in the eyes. Said to bring good luck to the wearer. **PRICE 25c Postpaid**

HOW TO PITCH Pitch the Fade-a-way, Spitter, Knicker, and other novelties. Includes instructions by leading Big League Pitchers. Clearly illustrated and described with 66 pictures. **POSTPAID 25c**

JAPANESE ROSE BUSHES

The Wonder of the World Japanese Rose Bushes bloom all the year round. Just think of it. Six weeks after planting the seed, the plants will be in full bloom. It may not seem possible, but we positively guarantee it to be so. They will bloom every ten weeks, in Summer or Winter, and when three years old the bush will be a mass of roses, bearing from five hundred to a thousand roses on each bush. The flowers are in three shades—white, pink, and crimson. The plants will do well both in and out doors. We guarantee at least three bushes to grow from each packet of seed. **Price, 10c packet, 3 pkts. for 25c Postpaid.**

Chinese Fragrant Tree Fern

Just introduced, noted for its rapid growth. An exceptionally pretty ornamental plant. Foliage is rich dark green. Forms grand pyramidal bushes about 6 feet high. Fronds very desirable for decorative purposes, wreaths, etc. **Seeds 15c pkt., 3 for 40c.**

Weather Plant

NATURE'S WEATHER PROPHECY By the Chinese, this remarkable plant accurately forecasts the weather many hours in advance. Will grow anywhere all the year around. An interesting house plant. Bear large, fragrant, pink, butterfly shaped flowers. **Seeds, 15c packet, 3 for 40c. Postpaid.**

GROUND ALMONDS

Amazingly Prolific—Easily Grown From Seed The Ground Almond has a flavor that is MOST EXCELLENT, resembling the coconut. The meat is snow white, covered with a shell or skin of brown color. It grows close to the surface and anything from 300 Almonds may be expected from a single nut. There is no trouble whatever in growing any where and in any kind of soil. May be planted any time, and in an ENORMOUS CROP. The most DELICIOUS ALMONDS YOU EVER TASTED. **Seeds 15c Pkt.**

Chinese Cabbage

Novelty from China and should be grown in every garden. Cross to be a Green Chinese Cabbage and Oca Lettuce. A flavor is more mild than any other cabbage. Can be served on the table and eaten raw cooked like cabbage, spinach or lettuce or made into salad. Grows very rapidly, easy to cultivate. You can create quite an sensation by cultivating this remarkable novelty. **Seeds, 15c packet, 3 pkts. for 40c.**

TREE OF HEAVEN

This splendid ornamental tree is a native of China, and is called the Tree of Heaven on account of its great beauty. It grows in any soil, no matter how poor, and grows from 6 to 9 feet high from the first summer. The tree is from 5 to 6 feet in any length, giving it a fine appearance. Nothing outside the tropics can rival it for decorative value. Large panicles of bloom, followed in season by great clusters of colored seeds. The tree a continual thing of beauty. **Packet, 15c; 3 Packets 40c.**

THE REMARKABLE FIREFLY PLANT

Flows at Night with Fragrant Aroma One of the most rapid growing vines known. Under favorable conditions this vine has been known to grow OVER 26 FEET IN A SINGLE WEEK. It is a very short species of time indeed the vine has climbed to a great height, and is covered with IMMENSE FLOWERS, from 5 to 7 inches in diameter. It is indeed a great novelty for unlike other plants, the flowers OPEN IN THE EVENING, and remain open until about noon the following day. In dull weather they will remain shut on all days. It is a most INTERESTING SIGHT to watch the opening and closing of the flowers as the clouds appear and disappear. As the flowers open they give forth the most DELICIOUS FRAGRANCE, and the atmosphere around is full of scented fragrance. It is always the object of favorable comment, and much curiosity is aroused by people passing at night time as to the cause of the charming aroma. frequently stopping in an endeavor to satisfy their curiosity. **PRICE, 10 CENTS packet, two packets for 35 CENTS. POSTPAID. JOHNSON SMITH & CO.**

The Great Wonderberry

A luscious berry that may be grown and ripened from seed in any soil of climate in 3 months. The flavor is rich and surpassed for eating raw, cooked, canned or preserved in any form. The fruit is blue-black in color, and tastes like a luscious, rich blueberry. One bush will produce an enormous amount of fruit, yielding great masses of rich fruit all Summer long. **Packet, 10c, 3 pkts. for 25c. Postpaid.**

Shoo Fly Plant

A very remarkable botanical curiosity! You should see this quite odorless it is said flies will not remain in room where it is. Bears very pretty blossoms; blooms summer and winter. **Seeds 15c pkt.; 3 for 40c. Postpaid.**

The Great Umbrella Palm

Easily Grown From Seed Winter or Summer The Japanese Umbrella Palm is semi-aquatic plant. It is easily grown from seed either in a bowl of water or in very damp soil. Probably the most useful, as well as the most interesting, method to cultivate the plant in a bowl or jardiniere filled with water, with two or three inches of good garden soil at the bottom. The seeds soon commence to fermenting, and the plant shoots up stems two to three feet high and rapidly assumes a most pretty palm-like appearance, as shown in the engraving. The top of the stems are surmounted by a whorl of umbrella-shaped leaves, of a waxy appearance. We will send a package of this seed, with full instructions for culture, for only 15c or three packets for 40c Postpaid.

Pertume Plant

Blooms only at night, giving forth the most delightful, recently discovered fragrance for quite low price. Grows in any garden. Also valuable because of rare perfume made from it. **SEEDS, 10c pkt., 3 for 25c.**

Perpetual CACTUS FROM SEED

Very curious, odd looking, strange species of plants; will thrive anywhere with little or no care. Flowers are of exquisite beauty and delightfully fragrant. You will be astonished at the odd looks of the cactus. **Packet, 10 cents, three packets for 25 cents. Postpaid.**

GIGANTIC GUINEA BUTTER BEANS

THE NEW EDIBLE VEGETABLE WONDER Grows to an astonishing size, the Beans measuring from 3 to 6 feet long, and weighing anything from 10 to 16 lbs, and even more. One Bean is sufficient for a family for several meals. Very palatable and rich in nutritive material. The delicate Buttery Flavor is much appreciated. The Vines are easily grown, very prolific, and a most welcome and valuable addition to your garden. Try them; you will find them the most delicious vegetable you have ever tasted. Imported direct. Unobtainable elsewhere. Sample packets of seeds with full directions for cultivating and cooking. **25c. Postpaid.**

Kudzu Vine

Most rapid growing vine known. Will grow 20 feet in one week. Luscious foliage, lovely purple flowers, very fragrant. Nothing to equal it for shade purposes and quick growth. **Seeds 15c packet, 3 for 40c.**

Yard Long Bean

Produces enormous crop of long, slender, round pods, of excellent quality for snap beans. Pods grow from 2 to 5 feet in length. Very tender and fine flavor. The vines are rampant growers; an interesting curiosity. **Seeds 15c, 3 for 40c.**

ADDRESS ORDERS FOR GOODS ON THIS PAGE TO

JOHNSON SMITH & CO.
DEPT. 969 RACINE, WIS.

Our complete Catalog sent on receipt of 10c., or the De Luxe Cloth Bound Edition for 25c. Bigger and better than ever. Only book of its kind in existence. Nearly 800 pages of all the latest tricks in magic, the newest novelties, puzzles, games, sporting goods, rubber stamps, unusual and interesting books, curiosities in seeds and plants, etc., unobtainable elsewhere. Remit by Coin, Money Order, Check or unused U. S., Canadian and Foreign Stamps for all articles listed above.

LATEST CATALOG **LATEST CATALOG**

A Good 14-Tube Receiver

(Continued from page 719)

detectors. We found that three stages of tuned radio frequency amplification, using 58 tubes, gave such a result and the signals then "played" through solid.

Radio Frequency Stages and Coils

In a receiver employing a great amount of amplification, as this one does, I think we can take the liberty of using coils on a one-inch diameter form. By having shorter plate leads and shorter grid leads, through the use of a smaller size tank to house the inductance, condenser and tube, the gain in efficiency "offsets" the greater gain of a more bulky inductance. The more metal in the way of shielding that can be eliminated, the greater the over-all efficiency. With the small coils, *inter-coupling* is so small when they are spaced on 1 1/2 inch centers, the partitions between stages are found unnecessary. With one-inch hand wound coils it is possible to remain closer to form factor with No. 20 D.S.C. wire without having to "space-wind" them.

The lay-out of each tank is such that the tube is in the rear extreme right-hand corner. A piece of one-eighth bakelite, 4 x 5 inches, is provided for each tank of the R.F. stages and is mounted with two 3 1/2 x 1/4 inch stove-bolts through the base, spaced from the base with copper tubing three-eighth inch inside diameter and three inches long. This gives a platform of insulating material in each tank, setting three inches from the base, and to this bakelite the coils are secured, properly spaced, three on the bottom and number two coil on top. A place on the right rear is cut out for the tube shield to pass through, and the inductance switch is secured to the rear left-hand corner, so it is close to the plate lead from the tube in the preceding tank. The bottom gang of the switch is used for the plate coil and the top is used for the grid. Each switch is turned separately for each circuit to change from coil to coil.

A four-prong socket is mounted on these bakelite platforms on top and as near center of apparatus as possible, when the assembly is mounted, this socket occupying the fifth tap on the inductance switch, so the range of the set may be extended beyond the four fixed coils, and also 1 1/2 inch coils may be used.

The four tuning condensers of the radio frequency stages are 100 mmf. each, and are ganged to turn on one shaft running

parallel with the panel. This gang is operated by a drum dial.

There is one mounting of 32 oz. copper (soft) for each condenser and its trimmer. This mounting is trimmed down as narrow as possible to eliminate metal and yet large enough to hold the condensers securely.

These mountings also carry the .00025 mf. midget trimmer which is set at right angles with the regular tuning condenser so the shafts come through the panel. The 100 mmf. tuning condensers are suspended as far from the shielding as practical, this being found a necessary help. The copper mountings have a slot cut in the top for the condenser bushing to drop into, spacing the shaft four inches from the base at the bottom and 2 inches from the panel.

A prong is bent at right-angles for the trimmer and a flange is provided at the bottom to secure it to the base with two screws. The trimmer shaft is spaced 1 1/4 inches from the base at the bottom.

The radio frequency tubes, three of them, are mounted in one unit which consists of a housing made of 32 oz. copper or a casting, 1 1/2 inches high, giving enough space to mount it flush on the top of the base with shielding between sockets, thus giving the sockets underneath shielding on four sides, from any other part of the set. The entire unit is wired with all by-pass condensers and cathode resistors self-contained. All the screens are ganged, the heaters, cathode resistors and suppressors are ganged and the leads to them threaded through the bottom of the base, while the plate leads are brought out separately on top. All connections and feeders to these leads shall be good shielded cable. The entire unit is mounted within an eighth of an inch of the intermediate transformer tanks, just allowing enough space for the R.F. tank back to fit between.

All the cathode resistors must be uniform and should be checked on a resistance bridge or ohm-meter. Their value may range between 150 and 250 ohms. All by-pass condensers in the R.F. stages are .01 mf. unless otherwise indicated on the diagram.

One R.F. plate load reactance is provided for the three tubes in the form of a radio frequency choke of 85 mh. It would be difficult to get three perfectly matched in inductance and resistance over the entire band of frequencies, therefore we prefer to use just one, so the three tubes are uniform.

Coil Data—Acme 14 Tube Receiver

No.	Length of Form	— OSCILLATOR —				— RADIO FREQUENCY —			
		Turns Plate	Grid	Range KC.	Dial	Turns Plate	Grid	Range KC.	Dial
1	1 1/4 inches	4	3 3/4	27,500	25	3	3 3/4	27,500	25
				26,500	27			26,500	35
				25,500	30			25,500	45
				24,500	34			24,500	50
				23,500	38			23,500	58
				22,500	42			22,500	65
				21,500	45			21,500	70
				20,500	51			20,500	75
				19,500	56			19,500	80
				17,780	74			17,780	90
				15,000	80			15,000	95
2	1 1/4 inches	8	7 1/2	15,000	17	5	7 1/2	15,000	5
				14,000	33			14,000	25
				13,000	45			13,000	40
				11,500	60			11,500	55
				10,500	75			10,500	65
				9,800	85			9,800	75
				9,500	92			9,500	80
3	1 1/4 inches	13	13 1/2	9,000	6	8	13 1/2	9,000	5
				8,500	15			8,500	10
				7,000	60			7,000	60
				6,600	70			6,600	70
				6,100	82			6,100	85
				5,500	92			5,500	95
				5,000	10			5,000	10
				3,500	45			3,500	50
4	2 inches	21	21	2,500	85	15	21	2,500	90
				2,500	85			2,500	90

QUALITY APPARATUS FOR Short Waves

GEN-WIN SHORT WAVE COIL KIT



These coils are considered the finest made. Each coil is precision wound on a different colored bakelite form for quick identification of wave lengths. Used and highly recommended by all short wave experts. Range (16 to 225) meters, using a .00014 or .00015 mfd. condenser. Recommended for the following sets: "The Globe Trotter," "The Overseas," "The Doerle 12,600 Mile Two Tube Receiver and Doerle Three Tube Signal Gripper," "The Megadyne."

4 Coil Enamel Wire Kit\$1.50 } 4 Coil Litz Wire\$2.25
Broadcast Coil. (200 to 550 meters) 55c

POLICE AND SHORT WAVE ADAPTER

Convert your broadcast set into a shortwave set tuning from 80 to 200 meters.



Get exciting police alarms from stations thousands of miles away. Atlantic communications while planes are in flight. Amateur short and international code communications. The biggest thrill and fun for so little money. Installed in a jiffy. Plug directly into the detector tube socket. Specify the detector tube in your set, or if uncertain as to detector tube, advise make and model number of set when ordering.

No. 200—for '27, '37 \$1.39 and '58 Det. tube
No. 201—for '24, '35, and '36 Det. tube \$1.39

ALL-WAVE COIL KIT Range 25 to 550 Meters

Comprises precision wound R.F. coil, both having tapered sections on det. side, which permits you to use either both SHORT WAVE and R.F. COILS. CAST PRO-GRAMS. If you own an Ambassador or any other three circuit tuner receiver, you can easily convert the set into an all wave receiver, by replacing the coils with these new GEN-WIN ALL-WAVE coils. Coils may be had for use with either .00014 or .00015 Mfd. condenser. Specify which when ordering. Wiring diagram included free with coils. Separately 10c.



All Wave Tuner (as illustrated)90c
All Wave R. F. Coil.....75c

Send remittance in check or money order. Register letter if it contains currency.

GENERAL WINDING COMPANY
254 W. 31st St. Dept. 4-3 NEW YORK, N. Y.

LEARN CODE QUICKLY AND EASILY and become a Skilled Amateur or Radio Operator AT HOME

FREE—NEW BOOK OF FACTS, just published—tells you of easiest, quickest and, according to leading authorities, best method of learning code, developing high speed, necessary fundamentals of radio, building your station, passing government exam., and getting on the air.

WATSON, WIBGL, op. Bear of Oakland, Byrd Expedition, says: "Candler System enabled me to pass rigid competitive test for this position."

Many instructors and ops in U. S. Army, Navy, Aviation, Marines and Coast Guard are Candler trained. 22 years successful experience and thousands of the most skilled amateurs and commercial operators back of CANDLER SYSTEM.

Ask any efficient amateur or commercial op about us. One graduate held championship 13 years. Our 9 year old student won championship in 4 1/2 months after beginning CANDLER SCIENTIFIC CODE COURSE. Is it any wonder we have imitators?

Whole interesting story of Radio Communications contained in new Book of Facts, pictures of champions and Candler System Code Guild members. Whether you are a beginner with no knowledge of code or operator with need for SPEED, this book will be valuable to you. A card will bring it.

CANDLER SYSTEM CO.,
Dept. 8-4
6343 South Kedzie Avenue
Chicago, Illinois

World's Only Code Specialist

Be a Television Expert

LEARN Radio and Television! Broadcast, Service, etc.

Leaders predict new system television requires thousands relay and broadcasting stations. Ultra-short waves permit 80,000 television stations in America alone. Here's opportunity Get in NOW and build up with new industry in new era. Thorough training qualifies for 1st Class Radiophone operator license. Real experience at Television Sta. WFLA. Write for free folder. "Pictures on the Air."

S. G. Noel, Pres. First National Television, Inc. Dept. 8-4 Power & Light Bldg. Kansas City, Mo.

The Handy SERVICEMEN'S MANUAL

Profitable Data

SEE BACK INSIDE COVER FOR BIG AD

TRY-MO RADIO COMPANY, INC. 825 COMMERCE ST. N.Y., N.Y.

Learn CODE

in HALF
the Usual Time!

It's Easy to do
at Home with
The NEW
MASTER



Code Teaching Machine

As a child, you understood spoken English long before you could read or write. You learned by Hearing. CODE is the same way! Why make it hard for yourself, trying to learn with old-fashioned printed lessons alone? HEAR as you learn, and learn in half the time, with The New Master Teleplex. This world-famous instrument records your sending visibly—then sends back to you through headphones! The natural method: beginners learn faster, ops speed up their wpm amazingly. Used by U. S. Army and Navy, R.C.A., A. T. & T., and others. We give you Complete Course, lend you instrument. Instruct you personally—all under MONEY. **BACK GUARANTEE.** Low cost, easy terms. Write now for folder S.W.C. 4—no obligation.

TELEPLEX COMPANY

76 Cortlandt Street New York, N. Y.

STOPPANI COMPASS

A Precision Instrument made in Belgium. Purchased by the U. S. Government at more than \$30.00 each. Ideal for Radio Experimenters Laboratory, also may be used as a Galvanometer for detecting electric currents in radio circuits. Ruby, jeweled, solid bronze, 4 inches square, fitted in a hardwood case.



Our price prepaid \$4.50 each

GOLD SHIELD PRODUCTS CO.
112 Chambers St. New York City

A SINGLE ACME HEADSET



brings in
England, Holland,
Germany, Barenguilla,
Columbia.

The ACME phone was used with an ALL WAVE AIR SCOUT one tube receiver built by the Allied Engineering Co., of New York City.

ACME phones are sold by all leading "Ham" stores. Buy from your local dealer.

ACME SPECIALTY COMPANY
2000 Mendel Street, Chicago, Ill., U. S. A.



In three to seven months we train you to secure amateur, commercial telegraph second-class, and radiotelephone first-class government licenses. We teach RCA Institutes, Inc., texts. When you secure license, you receive practical experience in Studio and microphone technique in our own broadcast studios, and operating experience on a 1000-Watt W. E. Commercial Broadcast station. The lowest priced THOROUGH Radio engineering course in America.

PORT ARTHUR COLLEGE

Port Arthur (world-known port), Texas
RETURN COUPON FOR DETAILS

Name

Street or Box.....

City and State.....

All primaries are wound with No. 28 D.S.C. and all secondaries are wound with No. 20 D.S.C., except No. 4 coil, secondary of which is wound with No. 28 D.S.C. All forms are one inch O.D.

The secondary of coil No. 1 is space wound one-eighth inch on centers, or slightly more. This is the only space wound coil.

The secondary of the fourth R.F. coil in each set should be one-half turn less than the others.

The high potential side of secondary, or the grid lead, is next to the plate coil on all transformers, except THE OSCILLATOR, WHERE THE HIGH POTENTIAL SIDES ARE OPPOSED, EACH BEING ON OPPOSITE OUTER EDGES OF THE FORM.

In winding, start with the wire coming in over the top of the form, having it come from the direction opposite you. Start the secondary at the right end, the beginning is the ground lead or grid return. The end of this winding is the high side or grid lead and should go directly from the outside of the center of the form to the switch or grid. Try never to run the grid wire to some contact on the end of the form, for it then must pass through the air core and cut the field, or lines of force. Next wind the primary, starting it a half-inch from the grid lead. This start of the primary is the B-PLUS LEAD and the finish of the winding at the outer edge of the form is the PLATE LEAD.

The frequency settings shown are only relative, but should show up as indicated within a few points one way or the other, depending upon wiring and spacing of parts, which of course cannot be expected to be the same in every set unless the parts are stamped out. The readings are given as they show on a 0 to 100 dial.

Parts List—14 Tube Receiver

CONDENSERS

- 5 Hammarlund Type MC 100 S, 100 mmf. (or National).
- 5 Hammarlund Type MC 20 S, 20 mmf. (or National).

FIXED CONDENSERS

- 2 .5 mf.
- 14 .1 mf. For intermediate amplifier and as per diagram.
- 16 .01 mf. For radio frequency amplifier and as per diagram.
- 1 .002 mf.
- 1 .001 mf.
- 2 .0001 mf.
- 1 8 mf. filter condenser, electrolytic, D.C. peak volts 600.
- 1 4 mf. filter condenser, electrolytic, D.C. peak volts 600.
- 1 25 mf. by-pass for 59 cathode resistors, peak volts 10.

RESISTANCES*—Pig-Tail Type

- 3 150 ohms, 1 watt, radio frequency cathodes.
- 3 500 ohms, 1 watt, intermediate frequency cathodes.
- 1 150,000 ohms, 1 watt, grid of 56 audio tube.
- 1 250,000 ohms, 1 watt, cathode circuit of 55.
- 1 250 ohms, 1 watt, bias of 55.
- 1 500,000 ohms, 1 watt, grid circuit of 55.
- 1 100,000 ohms, 1 watt, plate load of 55.
- 1 1,000 ohms, 1 watt, cathode of 58 R.F. detector.
- 1 15,000 ohms, 1 watt, cathode of 57 R.F. detector.
- 1 1,500 ohms, 1 watt, cathode of oscillator.
- 1 350 ohms, 3 watts, cathodes of 59's.
- 1 20,000 ohms, 3 watts, screens of detectors.
- 1 10,000 ohms, 3 watts, screens of R.F. tubes.
- 1 20,000 ohms, 3 watts, plate of oscillator.
- 1 15,000 ohms, 3 watts, screens of intermediate.
- 1 2,500 ohms, 3 watts, cathode of 56 audio.

* Lynch or I. R. C.

A NEW DEAL

In Microphone Values!

A \$17.00
Microphone
Outfit
for only
\$5.95

Sent postpaid on receipt of remittance or C.O.D. plus charges.



No. 6 Mike and Stand

YOU GET

- 1 Model No. 6 Microphone List \$10.00 Sold separately at \$2.95
- 1 Model No. 6 Stand with individual call letters List \$3.50. Sold separately \$1.75
- 1 Shielded matching transformer List \$2.75 Sold separately at \$1.45
- 1 75c 3-conductor 8 foot microphone cable Sold separately at 45c

Description of Model No. 6
Model No. 6 is a bright aluminum finish, precisely machined Mike—3 1/2 in. diameter—1 in. thick—weighs 8 oz. Has gold plated stretched diaphragm—gold plated buttons—200 ohms each—frequency 40 to 3500 cycles within 4 Db. Send your order in now! These prices may never be repeated. Every Lifetime product unconditionally guaranteed to please you or your money back. Send for catalog illustrating complete line of Microphones and Electro-Dynamic Sound Equipment at America's Lowest Prices.

The LIFETIME CORP. 1303 Dear St. Toledo, Ohio

SEXOLOGY

THE MAGAZINE OF SEX SCIENCE

SEXOLOGY, foremost educational sex magazine, is written in simple language and can be read by every member of the family. It is instructive, enlightening—not a risqué book—contains no jargon. Devoted to Science of Health Hygiene.

Contains 25 important articles on Sex Science, 68 pages, with attractive two-color cover. Here are a few of the more important articles:

- Truth in Sex Literature; Chastity Belts (illustrated); Sex "Inversion"; Superstitions About Virginity; Frequency of Sex Diseases; Double Pregnancy in Double Womb (illustrated); Cure of Syphilis Slow; Sex Knowledge for Children; Abnormalities of Female Breast (illustrated); Venereal Disease Prevention (illustrated); Continuous Menstruation; All About Your Glands (illustrated); Giants Are Impotent; The Menopause; The Message of the Urine (illustrated); Sex and Pain; Questions and Answers; Scientific Sex Notes.

Get a copy of SEXOLOGY on any newsstand, or, if your dealer cannot supply you, send 25c in stamps for a copy of the current issue.
SEXOLOGY 23 West Broadway New York, N. Y.

SUPER TESTING KIT!

Pencil Type Handles

with interchangeable Tip End. Kit complete with 2 Plug-In Probs, 2 Alligator Clips, 2 Needle Point Phone Tips, and 2 Spade Lugs. Long, Thin Pencil-Type handles for easy testing in tight places. Ideal for testing Long and Shortwave Sets, Coils, Condensers, Etc. Complete kit. Write for free catalog.

INTRODUCTORY PRICE NOW \$1.00 PREPAID
AMERICAN RADIO HARDWARE
135 Grand Street New York, N. Y.

NEW — FREE!! SHORT WAVE CATALOG

of coils, condensers, converters, chokes, crystal holders, antenna kits and hundreds of other standard S.W. items that sell fast. LIST PRICES quoted throughout. Send for YOUR FREE copy today.
Insuline Corporation of America
23-25 Park Place, WC-44 New York, N. Y.

JUST OFF THE PRESS!
Free **1934 RADIO AND AMPLIFIER CATALOG** **MAKE US YOUR**
HEADQUARTERS FOR PUBLIC ADDRESS AMPLIFIERS
Deal DIRECT with Manufacturers and **SAVE BIG MONEY!**
COAST TO COAST RADIO CORP.
104-5 WEST 17th ST., NEW YORK, N. Y.

SAVE! BUY NOW!

Prices are going up MAYO MICROPHONES

With the prices of materials going higher every day it will soon be necessary for us to advance our prices. Mayo microphones have gone over the top in sales. The radio trade is quick to realize real value at low price, and if it were not for the volume of sales that we have had we could not afford to sell this truly \$25.00 mike for \$5.00.

At Your Distributor or Sent Postpaid on Receipt of Remittance



\$5.00
NET TO THE TRADE

THE MAYO type "F" is a large, heavy, polished chromium plated, commercial type microphone two button, gold contacts, **NEW SPECIAL HEAT TREATED DURALUMINUM DIAPHRAGM**, on stretched cushion. Special process long life carbon. Frequency response 30 to 5000 cycles. Size 2½"x3½", weight 1¼ lbs. Furnished either 100 or 200 ohms per button.

If you cannot obtain this microphone from your distributor send us your order. **IF YOU ARE NOT THOROUGHLY SATISFIED RETURN WITHIN FIVE DAYS AND WE WILL REFUND PURCHASE PRICE.**

MICROPHONE REPAIRS

Repairing microphones is part of our vast service. Our complete equipment and trained engineers insure accurate repairs to any make or type of microphone.

OUR REPAIR PRICES ARE LOW
FLOATING DIAPHRAGM FROM... \$1.00 to \$2.50
STRETCHED DIAPHRAGM FROM... \$2.50 to \$4.50
OTHER PRICES ON REQUEST
CARBON—Special process for rebacking your own microphone, enough to repair five microphones—50c.

DISTRIBUTORS—Write for our proposition

MAYO MICROPHONES

19 Park Place New York, N. Y.

VEST POCKET SOLDERING IRON



Smallest good iron now on the market will do the work of irons twice its size. Only 10 inches long ½ inch in diameter. By using the highest grade elements, it heats up in half the time of ordinary irons. Guaranteed to give satisfaction or money back. We issue no catalog on this item.

Enclose \$1.00 and iron will be sent post-paid in U. S. 10c extra in Canada.

GOLD SHIELD PRODUCTS CO.
112 Chambers St., S.W., New York

WIRE-WOUND RESISTANCE

1 1,500 ohms, 25 watts, B supply of audio amplifier.

POTENTIOMETERS*

- 1 400 ohms, cathodes of R.F. tubes.
- 1 50,000 ohms, screens of R.F. detectors.
- 1 50,000 ohms, screens of I.F. tubes.
- 1 50,000 ohms, tone control.
- 1 500,000 ohms, AVC—ARC control.
- 1 20,000 ohms, audio output control.

TRANSFORMERS

- Audio input transformer (one 56 plate to two 59 grids).
- Power transformer (C.T., 400 to 450 V. each side, 130 ma. or larger).
- Filament transformer (2.5 volts, 12 amps, C.T.).

If Class "B" service desired, a Class "B" input transformer will replace the speaker "output" transformer. Two 59 plates to two 59 grids in Class "B". (National.)

SHIELDS

- 5 copper shields, 2½ x 5½, spun tops (home-made).
- 10 tube shields.

SOCKETS

- 2 5-prong wafer, for 56 tubes (Na-ald).
- 1 4-prong wafer, for 83 tubes (Na-ald).
- 9 6-prong wafer, for 58 tubes and 57 (Na-ald).
- 5 4-prong wafer, for auxiliary inductances (Na-ald).
- 2 7-prong large wafer, for 59 output tubes (Na-ald).

CONDENSER MOUNTS

- 4 for radio frequency tuning condensers and trimmers (home-made).
- 1 for oscillator condenser (home-made).
- 1 for band spread (home-made).

OTHER MOUNTINGS

- 1 3-gang mounting for R.F. tubes (home-made).
- 1 2-gang mounting for R.F. detector tubes (home-made).

MISCELLANEOUS PARTS

- 4 intermediate frequency transformers (home-made or Hammarlund, National or Gen-Win) (air condenser type 465 KC.).
- 1 0 to 15 D.C. milliammeter.
- 5 2-gang, 5-point inductance switches.
- 2 40 millihenry chokes, R.F. detector plates (National or Hammarlund).
- 2 85 millihenry chokes, R.F. amplifier plates and grid of 55 (National or Hammarlund).
- 1 8 to 16 henry filter choke not over 250 ohms D.C. Res., 150 ma.
- 2 10 to 20 millihenry chokes for plates of 83 (National or Hammarlund).
- 10 3½ x ¼ inch stove bolts and nuts.
- 10 copper tubes, 3 inches long by ¾ths inside diameter.
- 10 lbs. 32 oz. soft copper for base, shielding, tanks and panel.
- 5 pieces ¼th bakelite, 4 x 5 inches.
- 34 inches thin bakelite tubing, 1 inch O.D. for inductances.
- 1 lb. No. 20 D.S.C. copper wire.
- 1 lb. No. 28 D.S.C. copper wire
- 2 drum dials (National).
- 1 horizontal scale dial (National).
- 5 medium size knobs for inductance switches (with pointers).
- 6 large knobs for potentiometer controls (with pointers).
- 4 small knobs for trimmers (no pointers).
- 1 S.P.-S.T. switch for main switch.
- 1 fuse holder.
- 1 filament control jack for milliammeter in test of screen circuit of R.F. amplifiers.
- 9 grid caps (National).
- 7-58 tubes, 1-57 tube, 2-56 tubes, 2-59 tubes and 1-83 RCA (Arco).
- 8 in. brass ¼ in. shafting.
- 3 solid ¼ in. couplings, brass, and 2 flexible couplings, either Hammarlund or National.
- 15 ft. five ply speaker cable.
- 1 five prong speaker plug and five prong socket.
- 1 10 in. dynamic speaker or larger, 1,500 ohm field, R. T. Co.

* Acorn test. (Part II, conclusion, in the May number.)

RADIO for 1934

NO SERVICEMAN DEALER OR SET BUILDER CAN AFFORD TO BE WITHOUT THIS BOOK

Send for the most valuable book in Radio. Packed with quality and value. Lists the most complete line of radio replacement parts for any service requirement.



Features latest type set-building kits, test instruments, Long and Short Wave Radios, sound Systems, etc.

Write for this Catalog today!

FREE

ALLIED RADIO CORP.,

Dept. E, 833 W. Jackson Blvd. Chicago, Illinois. Please send me FREE your New 1934 Radio Book.

Name _____
Address _____
City _____ State _____

Allied Radio

Improved RECEPTION on ANY RECEIVER

RECEIVERS WITHOUT PHONE JACK



provided for earphone listening with PHONE RECEIVER. Installs without touching receiver's wiring. Inserting phone plug automatically silences speaker. Complete \$3.95

LYNCH NOISELESS ANTENNA SYSTEMS



Custom built, ready to attach to your masts or Lynch materials supplied (at 40% off list price) to assemble your own.

For suggestions and estimate on Antenna to meet your own requirements give receiver's make, available space and sketch of location.

- Lynch All-Wave Kit (list \$6.50) \$3.90
- Kit of 10 Transpos. Blocks (list \$2.75) \$1.65
- Kit of 8 Navy Insulators (list \$2.00) \$1.20

AMPLIVOX LABORATORIES
Chief Engineer: S. Perlman, E. E. Technical Advisor, N. Y. City, International S. W. Club, 647 East 96th St., Dept. SW-4 Brooklyn, N. Y.

THE INSTRUCTOGRAPH

(Code Teacher)

The Scientific, easy and quick way to learn the code. Send a post card today for literature. Machines, tapes and complete instructions for sale or rent. Terms as low as \$2.00 per month. Rental may be applied on purchase price if desired. Rent for a month. If the Instructograph meets every requirement, buy it. If not, send it back.

MISINSTRUCTOGRAPH CO. 612 LAKESIDE PLACE, CHICAGO

Turn to page 768 for Important Announcement on OFFICIAL RADIO SHORT WAVE MANUAL

... SHORT WAVE ESSENTIALS FOR MEMBERS OF THE SHORT WAVE LEAGUE ...

THE following list of short wave essentials has been prepared from the suggestions to the LEAGUE by its members. A number of months were consumed in creating these short wave essentials for members of the SHORT WAVE LEAGUE. All essentials listed are approved by headquarters of the LEAGUE.

A FEW WORDS AS TO THE PURPOSE OF THE LEAGUE

The SHORT WAVE LEAGUE was founded in 1930. Honorary Directors are as follows:

Dr. Lee de Forest, John L. Reinartz, D. E. Replogle, Hollis Baird, E. T. Somerset, Baron Manfred von Ardenne, Hugo Gernsbach, Executive Secretary.

The SHORT WAVE LEAGUE is a scientific membership organization for the promotion of the short wave art. There are no dues, no fees, no initiations, in connection with the LEAGUE. No one makes any money from it; no one derives any salary. The only income which the LEAGUE has is from its short wave essentials. A pamphlet setting forth the LEAGUE'S numerous aspirations and purposes will be sent to anyone on receipt of a 3c stamp to cover postage.

One of the aspirations of the SHORT WAVE LEAGUE is to enhance the standing of those engaged in short waves. To this end, the SHORT WAVE LEAGUE supplies members with membership letterheads and other essentials. As soon as you are enrolled as a member, a beautiful certificate with the LEAGUE'S seal will be sent to you, providing 10c in stamps or coin is sent for mailing and handling charges.

Another consideration which greatly benefits members is that they are entitled to preferential discounts when buying radio merchandise from numerous firms who have agreed to allow lower prices to all SHORT WAVE LEAGUE members. The radio industry realizes that, the more earnest workers there are who boost short waves, the more radio business will result therefrom; and a goodly portion of the radio industry is willing, for this reason, to assist SHORT WAVE LEAGUE members by placing them on a professional basis.

SHORT WAVE ESSENTIALS LISTED HERE SOLD ONLY TO SHORT WAVE LEAGUE MEMBERS

All the essentials listed on this page are never sold to outsiders. They cannot be bought by anyone unless he has already enrolled as one of the members of the SHORT WAVE LEAGUE or signs the blank on this page (which automatically enrolls him as a member, always provided that he is a short wave experimenter, a short wave fan, radio engineer, radio student, etc.).

If, therefore, you order any of the short wave essentials without filling out the blank (unless you already enrolled as a LEAGUE member), your money will be returned to you.

Inasmuch as the LEAGUE is international, it makes no difference whether you are a citizen of the United States or any other country. The LEAGUE is open to all.

Application for Membership SHORT WAVE LEAGUE

SHORT WAVE LEAGUE (4-34)
98 Park Place, New York, N. Y.

I, the undersigned, herewith desire to apply for membership in the SHORT WAVE LEAGUE. In joining the LEAGUE I understand that I am not assessed for membership and that there are no dues and no fees of any kind. I pledge myself to abide by all the rules and regulations of the SHORT WAVE LEAGUE, which rules you are to send to me on receipt of this application.

I consider myself belonging to the following class (put an X in correct space): Short Wave Experimenter Short Wave Fan Radio Engineer Student

I own the following radio equipment:

Transmitting
Call Letters.....

Receiving
Name

Address

City and State.....

Country

I enclose 10c for postage and handling for my Membership Certificate.

SHORT WAVE LEAGUE LETTERHEADS

A beautiful letterhead has been designed for members' correspondence. It is the official letterhead for all members. The letterhead is invaluable when it becomes necessary to deal with the radio industry, mail order houses, radio manufacturers, and the like; as many houses have offered to give members who write on the LEAGUE'S letterhead a preferential discount. The letterhead is also absolutely essential when writing for verification to radio stations either here or abroad. It automatically gives you a professional standing.

A—SHORT WAVE LEAGUE letterheads, per 100..... **50c**

OFFICIAL SHORT WAVE LEAGUE LOG AND CALL MAGAZINE

Here is the finest book of its kind ever published. It contains the largest listing of short wave stations in the world, much larger in fact than the list published in SHORT WAVE CRAFT and other magazines. All experimental stations, no matter where located, are listed. A large section is provided where calls can be listed in a proper manner. This log section gives out callings, time, date, call letters, location, and other information. Another section has squared-paper pages on which you can fill in your own frequency curve for your particular receiver. It helps you to find stations which otherwise you could never log. It is the only book of its kind published.

B—Official Log and Call Magazine.....Prepaid **25c**

RADIO MAP OF THE WORLD AND STATION FINDER

The finest device of its kind published. The world's map on heavy board is divided into 23 sections, while the rotary disc shows you immediately the exact time in any foreign country. Invaluable in logging foreign stations. Also gives call letters assigned to all nations. Size 11"x22".

C—Radio Map of the World and Station Finder.....Prepaid **25c**

GLOBE OF THE WORLD AND MAGNETIC COMPASS

This highly important essential is an ornament for every den or study. It is a globe, 6 in. in diameter, printed in fifteen colors, glazed in such a way that it can be washed. This globe helps you to intelligently log your foreign stations. Frame is of metal. Entire device substantially made, and will give an attractive appearance to every station, emphasizing the long-distance work of the operator.

D—Globe of the World.....Prepaid **\$1.25**

SHORT WAVE LEAGUE LAPEL BUTTON

This beautiful button is made in hard enamel in four colors, red, white, blue and gold. It measures three quarters of an inch in diameter. By wearing this button, other members will recognize you and it will give you a professional air. Made in bronze, gold filled, not plated. Must be seen to be appreciated.

E—SHORT WAVE LEAGUE lapel button.....Prepaid **35c**

EE—SHORT WAVE LEAGUE lapel button, like the one described above but in solid gold.....Prepaid **\$2.00**

SHORT WAVE LEAGUE SEALS

These seals or stickers are executed in three colors and measure 1 1/4 in. in diameter, and are gummed on one side. They are used by members to affix to stationery, letterheads, envelopes, postal cards and the like. The seal signifies that you are a member of the SHORT WAVE LEAGUE. Sold in 25 lots or multiples only.

G—SHORT WAVE LEAGUE seals.....per 25, Prepaid **15c**

SHORT WAVE MAP OF THE WORLD

This beautiful map, measuring 18x26 in. and printed in 18 colors is indispensable when hung in sight or placed "under the glass" on the table or wall of the short wave enthusiast. It contains a wealth of information such as distances to all parts of the world, political nature of the country in which a broadcast station is located, etc., and from the manner in which the map is blocked off gives the time in different parts of the world at a glance.

F—SHORT WAVE Map of the World.....Prepaid **25c**

PLEASE NOTE THAT ABOVE ESSENTIALS ARE SOLD ONLY TO MEMBERS OF THE LEAGUE—NOT TO NON-MEMBERS.

Send all orders for short wave essentials to SHORT WAVE LEAGUE, 98 Park Place, New York City.

If you do not wish to mutilate the magazine, you may copy either or both coupons on a sheet of paper.

SHORT WAVE LEAGUE, 98 Park Place, New York, N. Y.



G—15c for 25

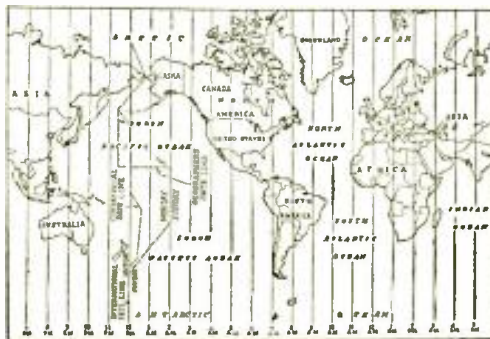

F—25c each



A—50c per 100



B—25c per copy



C—25c each



D—\$1.25 each



E—35c each



WE DO OUR PART

SHORT WAVE LEAGUE, 98 Park Place, New York, N. Y.

Gentlemen:
I am already an enrolled member in the SHORT WAVE LEAGUE
I am a new member and attach my application to this coupon.
Please send me the following short wave essentials as listed in this advertisement:

.....
.....
.....
.....
.....
.....

for which I enclose \$..... herewith.
(The LEAGUE accepts money order, cash or new U. S. Stamps in any denomination. Register cash and stamps.)

Name.....
Address.....
City and State.....
Country.....

(4-34)

• Index to Advertisers •

A	
Acme Specialty Company.....	755
Alan Radio Company.....	755
Alden Products Co.....	750
Allied Engineering Co.....	761
Allied Radio Corporation.....	765
American Machine & Tool Co.....	757
American Radio Hardware Co.....	764
American Sales Co.....	760
Amplivox Laboratories.....	765
Arco Tube Company.....	746
B	
Birnback Radio, Inc.....	757
Brian, The Radio Man, Inc.....	761
Bliley Piez. Electric Co.....	761
The Breakers.....	755
C	
Candler System Co.....	763
Coast-to-Coast Radio Corp.....	764
Coyne Electrical School.....	753
D	
Data Print Co.....	756
F	
First National Television, Inc.....	763
Fordson Radio Mfg. Co.....	767
G	
General Winding Co.....	763
Gold Shield Products Co.....	764-765
H	
"Ham" Advertisements.....	754
Hannarlund Manufacturing Co.....	745
Harrison Radio Company.....	747
I	
Instructograph Co.....	765
Insuline Corp. of America.....	757-764
International Correspondence Schools.....	757
L	
Lancaster, Allwine & Rommel.....	760
Leotone Radio Co.....	760
Lifetime Corp.....	764
Lynch Manufacturing Co.....	761
M	
Mayo Microphones.....	765
McGraw-Hill Book Co., Inc.....	750
Midwest Radio Corp.....	Back Cover
Miles Reproducer Co.....	761
N	
National Co., Inc.....	749
National Radio Institute.....	708-709
P	
Port Arthur College.....	764
Postal Radio Co.....	750-761
R	
Radio Publications.....	705
Radio Trading Co.....	758-759-760
RCA Institutes, Inc.....	757
RCA Radiotron Co., Inc.....	Inside Front Cover
S	
E. M. Sargent Co.....	755
Maurice Schwartz & Son.....	757
Sexology Magazine.....	764
McMurdo Silver, Inc.....	748
Silver-Marshall, Inc.....	751
Johnson Smith Company.....	762
Supertone Products Co.....	752
T	
Teletex Company.....	764
Try-Mo Radio Co., Inc.....	Inside Back Cover-750-760-763-767
U	
Uncle Dave's Radio Shack.....	751
W	
Wellworth Trading Company.....	752
Wholesale Radio Service Co., Inc.....	743-750-757

(While every precaution is taken to insure accuracy, we cannot guarantee against the possibility of an occasional change or omission in the preparation of this index.)

Static Alarm

(Continued from page 722)

foot letters HIO ESPUN HOSIERY. "HUGH," Jerry muttered, "wish the thing were grounding now. Maybe it would wake someone up down there." He pulled himself erect with a start. Going to the control cabinet he stopped the flasher action at the point where the whole sign was on at one time.

Gathering up a length of wire he climbed to the top of the sign level with the phrase "FOR COMFORT." Cutting off a piece of the wire he hooked it onto the terminals of "FORT." "COMFORT" never applied to this situation anyway. "COM" expressed the needs of the hour far better. There was left in his hand about three feet of wire. One end of this he fastened to the metal of the structure. The other end he brought near the terminal of "COM." The seven thousand volts jumped the gap and with a buz-z-z "COM" was in darkness. After a few experimental tries Jerry began. Dit dit dit dah dah dit dit dit: "COM" blinked it out slowly and as it did so crashed into the neighboring speakers. SOS SOS SOS BURGLARY HUB BLDG POLICE POLICE SOS. Thinking the sounds might be more likely to catch the ear of any possible amateur he began some of the appeals CQ CQ CQ 1MZ CALLING CQ CQ. Then he would go on with the plea SOS HUB BLDG BURGLARY POLICE SOS . . . etc.

ICWN threw down his pencil in anger and, mumbling some invectives against the world in general and the HOMESPUN sign in particular, trumped the length of the attic shack in an atmosphere of blackest gloom. This made the third Wednesday in succession that that sign had wrecked his pet sked with Ireland. How long would even the Irishman's good nature hold out? Maybe the Irishman could understand. Maybe they had neon signs in Galloway too. Maybe . . . That thought was never finished. Frank Truslow, ICWN to you, had reached the end of the attic and was gazing out the window directly at the HOMESPUN sign. In fact, he had been gazing at it for several seconds; long enough to note that it was burning steadily instead of flashing. As he reached his third "maybe" he noted also that in the center of the top line there was something that was flashing. COM COM COM COM. On and off it flashed and seemed to burn its way into his brain. Suddenly he realized why. It was because behind him on the bench the speaker was pouring forth crashes and these crashes corresponded exactly with the blinking of the "COM"! Just then it rolled in. Buz-z-z bz buz-z-z bz buz-z-z huz-z-z bz buz-z-z—CQ! What th . . . Signs don't talk! But they do! It is a CQ! Then he read ". . . SOS SOS SOS HUB BLDG BURGLARY POLICE QUICK POLICE FIRE STAIRWAY SECOND FLOOR SOS SOS POLICE SOS . . ."

In the newspaper the following morning, the temperature on the sign structure was solemnly quoted as four below zero and Jerry would have rated that as conservative. Much was made of his heroic taming of seven thousand volts at one hundred seventy feet in the air and who was going to bother enlightening the public that its frequency was too high and the current too low to ever prove really deadly. Morning papers were not served to the three gentlemen occupying cell number 652 so they did not learn until later the cause of their capture. That next morning one of them was heard to remark, "it's magic, Butch, jus' magic. Them bulls musta been mind-readers." Frank Truslow had an excellent chance to endow the world with his opinion of neon signs but his story consisted entirely of a glowing admiration for Jerry's work. The reporters gained but one remark from Jerry himself—

"Yeah, the hams did come through, at that." And what might that mean to the EVENING HERALD?

**REMARKABLE
New CATALOG
OF SENSATIONAL
RADIO VALUES BY
FORDSON**

**SENT FREE — but WRITE TODAY!
DEAL DIRECT—SAVE UP TO 50%!**
Most elaborate catalog ever issued on our complete line of radios for every purpose, and in NEW VALUES we offer. Just off the press, already in big demand (includes complete technical information, circuit diagrams, etc.) To get your copy promptly send card or coupon AT ONCE!
4-TUBE ALL-WAVE SENSATION! Only in new catalog will you see this remarkable, powerful little 4-Tube All-Wave, AC-DC radio. Nothing like it ever produced! Brings all-wave to new low price for quality manufacture. Latest Air-Cell battery sets also shown! **ANY SET ON 30-DAY FREE TRIAL!** Fordson radios are guaranteed on money-back basis. Enjoy any set in your own home for 30 days—judge Fordson Value for yourself. Know why one owner writes: You are doing for Radio what Henry Ford did for Auto Industry—Not how cheap but how Good! Many models: AC-DC; battery; long and short wave; all-wave supers; 6 and 32 volt; console; all-electric auto radio. Sets for home, car, farm, camp, cottage, boat and foreign use. **GUARANTEED. 30-DAY TRIAL.**



FREE Send for new catalog. Prices will amaze you, from **\$9.45** UP
OUR AGENTS MAKE MONEY—no experience needed. Literature and sample sets **FREE.**
Write! Send Card or Coupon Today.

FORDSON RADIO MFG. CO.,
Dept. 4, 4183 Oakman Blvd., Detroit, Mich.
Send me FREE catalog and agent's offer (this is not an order).
Name
Address.....

Turn to page 754, the "Ham" Section of SHORT WAVE CRAFT. Read these advertisements. They contain offers that will interest you.

POWER TUNING

**Universal AC-DC
SHORT WAVE RECEIVER**

The circuit employs all recently developed tubes, 1-78, 1-2525, and 1-43 power output tube. Full efficiency due to the special voltage rectification circuit. Uses four plus-in coils for maximum efficiency and wide band spread. They cover the short wave band from 15 to 200 meters. Write for complete details.
Kit of Parts.....\$8.95
Set of Sylvania tubes.....3.25

TRY-MO RADIO CO., Inc.
15 CORTLANDT ST., 8-4 NEW YORK CITY

NOW READY

The First and Only

Short Wave Manual

WORLD'S GREATEST SHORT WAVE BOOK!

We are proud to present the first modern and complete book on Short Waves which has appeared in the field.

There has been a big boom in short waves during the past two years in spite of the depression. Tremendous progress has been made, but up to now there has not been an adequate book depicting all the progress that has been made. The 1934 OFFICIAL SHORT WAVE RADIO MANUAL now fills this need completely.

It is a big book in which you will find everything on short waves, regardless of what it might be. It is not only a complete manual, but a veritable encyclopedia of facts, information, hookups and illustrations. Lack of space does not permit a complete description of this comprehensive volume.

The Manual has been edited by Hugo Gernsback, Editor of SHORT WAVE CRAFT, and H. W. Secor, Managing Editor. If you are a reader of Mr. Gernsback's other publications, you know just about what to expect from this book—his greatest effort in the short-wave field.

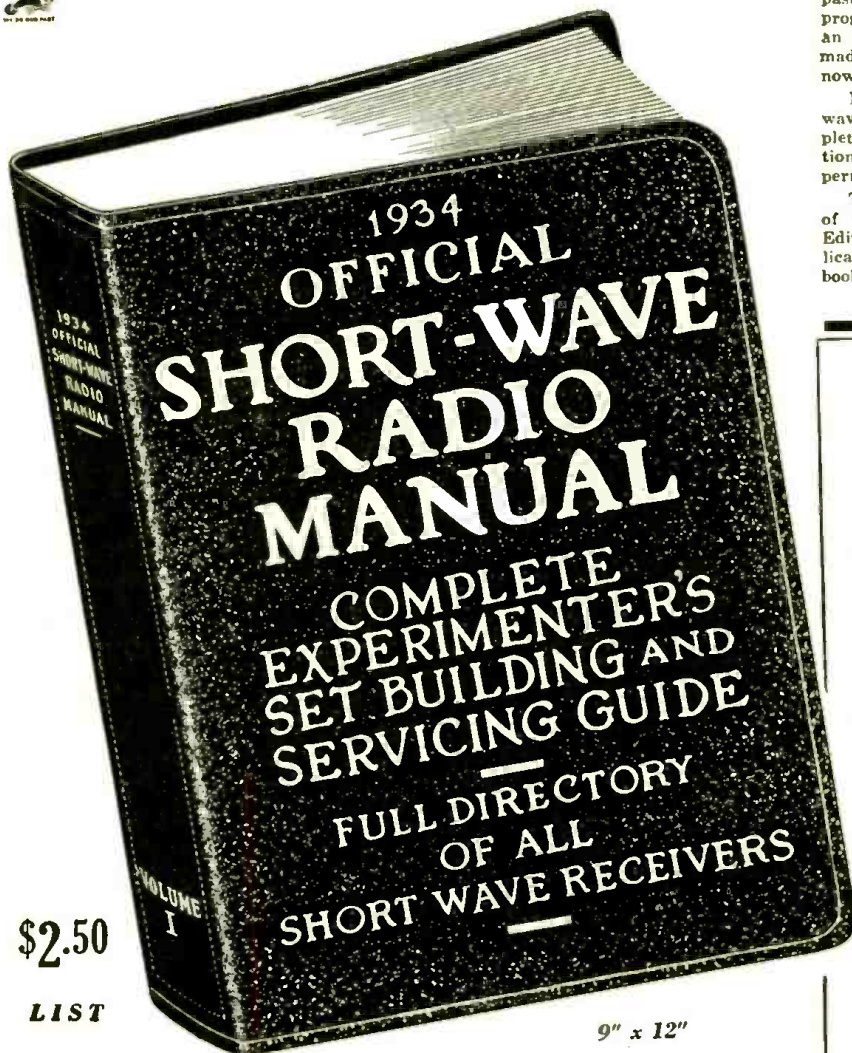

\$2.50

LIST

9" x 12"

Over 240 Big Pages

Over 1,000 Illustrations

Flexible, Looseleaf Leatherette Binder

CLIP — MAIL THIS COUPON TODAY!

SHORT WAVE CRAFT
96-98 Park Place, New York, N. Y.

Dept. SWC-434

Gentlemen: I enclose herewith my remittance of \$2.50 for which you are to send me, POSTAGE PREPAID, One Copy of the 1934 OFFICIAL SHORT-WAVE RADIO MANUAL. (Send remittance in check or money order. Register letter if it contains cash, stamps or currency.)

Name

Address

City..... State.....

15 VALUABLE FEATURES

- 1. A large section featuring the most important Short-Wave Receivers and how to construct them.
- 2. Short-Wave Transmitters in all their phases.
- 3. A complete Ultra Short-Wave Section featuring construction of 1, 3, 5 and 10 meter receivers.
- 4. A complete Short-Wave Beginner's section.
- 5. A section devoted exclusively to coil winding with all information about it.
- 6. A section on Commercial Short-Wave Receivers. Every important commercial receiver, including all-wave sets, is represented. Full servicing data is included which makes it invaluable for Service Men.
- 7. A section devoted to A.C. Short-Wave Power Packs and how to build them. These vary for 1 to 7 tube receivers.
- 8. A section for the Short-Wave Experimenter on short-wave kinks—hundreds of them.
- 9. A section on the important new art of Short-Wave Therapy (treatment of diseases by short waves).
- 10. A section devoted to Short-Wave Converters and their construction. Full servicing data on all commercial models is included.
- 11. A special section on Short-Wave Antennae and noise eliminating procedures.
- 12. A section on Short-Wave Superheterodynes. This section tells how to build them, including many commercial models of receivers. The latter with complete service data.
- 13. A section on Amateur 'Phone Transmitters and how to build them.
- 14. A Short-Wave Physics section on theoretical short-wave data for the advanced experimenter and radio student.
- 15. A most interesting section on Super-Regeneration in Short-Wave Receivers.

POWERTONE'S

6 Steps to WORLD-WIDE FAME



1 SCOUT One Tube All-Wave

Battery Operated
S.W. Receiver

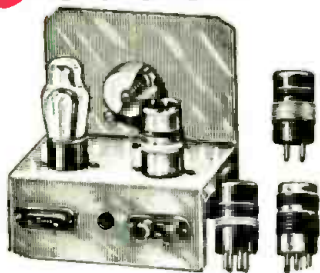

A set for the beginner! Will cover the entire short wave and broadcast bands. It is remarkable how the "Scout" intercepts short wave signals. Police signals, ship to shore, airplane, amateurs, etc., tuned with ease.

Parts in the kit are of the highest quality. Smooth regeneration control. Exceedingly

simple to build. Uses 1-230 tube, 2-1½ volt dry cells, and 1-45 volt "B" battery.

- Model SC-1-K Complete kit of parts.....\$3.95
- Model SC-1-W—Wired and tested.....Extra 1.00
- Sylvania 230 tube......70
- Set of batteries.....1.60
- Set of Matched headphones......95
- Broadcast coil—200-550 meters......39

2 POWERTONE Wallace Hoover Cup Winner Short Wave Receiver



Approved by Popular Mechanics, Short Wave Craft
Designed by Don C. Wallace, featuring band spread tuning and coupler for Doublet Antenna. Probably the finest two-tube, battery operated short wave receiver ever designed.

Uses the economical two-volt 230 tubes. Easily converted to A.C.

operation. Requires 2-1½ volt dry cells, and 45-135 volts "B".
One silver-wound, octo-formed coil included in each kit. Choice of one of the following 20-32, 40-60, 75-150, 150-200 meters.

- Model PW-2-K—Kit of parts.....\$10.90
- Model PW-2-W—Wired and tested.....Extra 2.00
- Model PW-2-T—Set of matched Sylvania tubes.....1.40
- Model PW-2-C—Each coil, additional......95

3 POWERTONE Three Tube A.C. Short Wave Receiver



15-550 METER TUNING RANGE
One of the most popular of the Powertone line of short wave receivers. Tuner and pack all built in one. Uses 1-56, 1-58 and 1-80 rectifier tubes.

Especially recommended for use with headphones. Covers both the short and broadcast band with the aid of plug-in coils. Rust-proof chassis is mounted into beautiful modernistic, crystal-finished cabinet.

Model SW5009-K—Kit of parts.....\$10.95

Model SW5009-W—Wired and tested...Extra. 2.00

- Set of matched Sylvania tubes.....1.95
- Set of matched headphones......95
- Broadcast coil (200 to 550 meters)......39

4 REGENT Four Tube A.C. Short Wave Receiver With Built-in Speaker

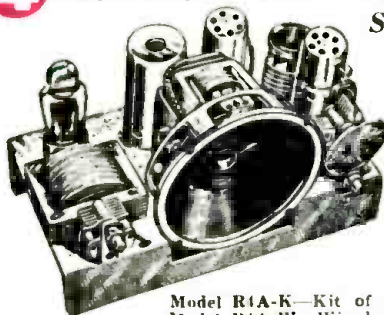

15 to 550 METERS
Up-to-the-minute in short wave design. Dynamic speaker is built directly into the chassis, making the entire receiver one unit. Built-in power supply.

World-wide, loud speaker reception. Uses 2-58's, 1-80 and 1-2A5 tubes.

Model R4A-K—Kit of parts.....\$11.50

Model R4A-W—Wired and tested...Extra. 2.00

- Complete set of Sylvania matched tubes.....2.50
- Modernistic cabinet.....1.50
- Broadcast coil (200 to 550 meters)......89

5 POWERTONE De Luxe Short Wave Receiver 15 to 550 Meter Range

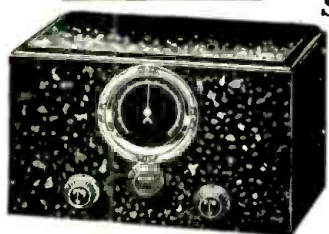

The latest addition to the famous line of Powertone short wave receivers. New type airplane dial. Built-in tuner and pack. Provisions for headphones. Low-loss, octo-formed coils. Uses 2-58's, 1-56, 1-80 and 1-59 tubes.

Model SW5008-K—Kit of parts.....\$24.50

Model SW5008-W—Wired and tested.....29.50

- Set of matched Sylvania tubes.....3.75
- Broadcast coil (200-500 meters)......89

6 POWERTONE 6 Tube All Wave Super-Het Short Wave Receiver

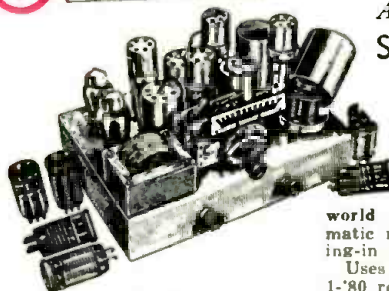

The most advanced model in the Powertone Short Wave Receiver line. Any experienced short wave fan can construct it with little effort. All the short wave offerings of the

world are at your finger tips. Automatic regeneration control aids in tuning-in the weaker stations.

Uses 1-2A7, 2-58's, 1-55, 1-2A5 and 1-80 rectifier tubes. Two sets of plug-in coils cover the short wave band. (14-200 meters.)

Model PS-6-K—Kit of parts with 8 coils.....\$24.50

Model PS-6-W—Wired and tested.....Extra. 5.00

- Set of matched Sylvania tubes.....3.95
- 2 Broadcast coils (200 to 550 meters), each......89

FREE
Servicemen's
Manual with
each Set.
Regular 25c.

TRY-MO RADIO CO., INC. 85 Cortlandt St. New York

Headquarters
for short wave
and trans-
mitting
equipment.

SEND FOR NEW 1934 CATALOG—FREE—

AMERICA TURNS TO MIDWEST!

AMAZING NEW SUPER-DELUXE

16-TUBE ALL-WAVE Radio

(9 TO 2000 METERS - 5 WAVE BANDS)

Is First Choice of Thousands of Radio Fans!

Big FREE Catalog Shows Sensational Radio Values

BEFORE you buy any radio, write for this big new FREE Midwest catalog... printed in four colors. It has helped thousands of satisfied customers save from 1/2 to 1/3 on their radios... by buying direct from the Midwest Laboratories. You, too, can make a positive saving of 30% to 50% by buying a Midwest 16-tube de luxe ALL-WAVE radio at sensationally low direct-from-laboratory prices. You'll be amazed and delighted with its super performance! Broadcasts from stations 10,000 miles and more away are brought in... "clear as locals." You get complete wave length coverage of 9 to 2,000 meters (33 megacycles to 150 KC.) Now, you can enjoy the new DX-ing hobby... and secure verifications from world's most distant radio stations.

WRITE FOR NEW FREE CATALOG



This Midwest ALL-WAVE Radio has FIVE distinct wave bands: ultra-short, short, medium, broadcast and long... putting the whole world of radio at your finger tips. Now listen in on all U. S. programs... Canadian, police, amateur, commercial, airplane and ship broadcasts... and programs from the four corners of the earth. Thrill to the chimes of Big Ben from GSB, at Daventry, England—tune in on the "Marseillaise" from FYA, Pontoise, France—hear sparkling music from EAQ, Madrid, Spain—enjoy opera from 12RO, Rome—listen to the call of the Kookaburra bird from VK2MF, Sydney, Australia. Listen to Admiral Byrd's broadcasts from "Little America" Taylor, of Ocean Beach, California, write: "Heard KATY, U. S. S. 'Bear', Byrd

FOREIGN STATIONS COME IN LIKE LOCALS
 Crawfordville, Ind.—I have heard HVJ, Vatican City, Italy; DJB, Zeesen, Germany; and YVIBC, Venezuela. They came in with the volume and clearness of any local station. I logged stations from Canada to Cuba, from coast to coast.
 JESSE BALLINGER, 207 Bluff St.

Expedition... near New Zealand, broadcasting phone conversation to U. S. A., etc. Never, before so much radio for so little money! Write for FREE catalog.

TODAY'S MOST POWERFUL LONG DISTANCE RECEIVER!

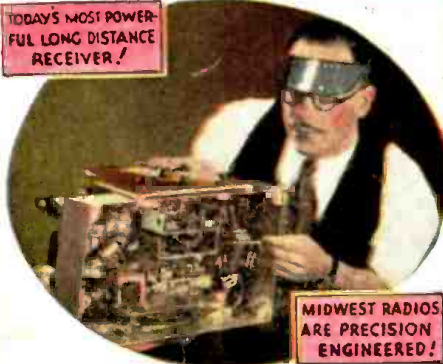

MIDWEST RADIOS ARE PRECISION ENGINEERED!

30-DAY FREE TRIAL PLAN STARTLES RADIO WORLD!

Try the Midwest radio you select from the free catalog... in your own home... for 30 days before you decide. Midwest can afford to make this sensational offer because, when you see and hear this bigger, better, more powerful, clearer toned, super selective radio you will want to own it—as so many thousands of men and women have done.

"40 NEW 1934 FEATURES"

See for yourself the 40 new 1934 features that insure amazing performance. Here are a few of these features: Automatic Select-O-Band, Amplified Automatic Volume Control, 16 New Type Tubes, Balanced Unit Superheterodyne Circuit, Super-Power Class A Amplifier, 29 Tuned Circuits, New Duplex-Diode-High Mu Pentode Tubes, Full Rubber Floated Chassis, Centralized Tuning, 7 KC. Selectivity, New Thermionic Rectifier, Automatic Tone Compensation, Auditorium Type Speaker, etc. These features are usually found only in sets selling from \$100 to \$150.

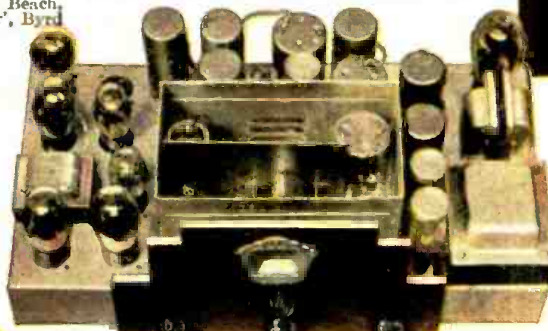

WORLD'S GREATEST RADIO VALUE

\$59.50

with New Deluxe Auditorium Type SPEAKER



MAINTAINING CONTACT WITH W9XZ (STRATOSPHERE BALLOON)

Recently, the Official Radio News Observer for Pennsylvania reported that his Midwest Super De Luxe 16-tube ALL-WAVE radio maintained contact with W9XZ (Stratosphere Balloon) when other sets lost signals.

NEW STYLE CONSOLES

Write quickly for your FREE copy of the new Midwest catalog. It pictures a complete line of beautiful, artistic de luxe consoles and chassis... in four colors! Sensational low prices save you 30% to 50%. You can order your Midwest radio from this catalog with as much certainty of satisfaction as if you were to select it personally at our great radio laboratories. Write TODAY!

TERMS AS LOW AS \$5.00 DOWN

DEAL DIRECT WITH LABORATORIES

SAVE UP TO 50%

Increasing costs are sure to result in higher radio prices soon. Buy before the big advance... NOW, while you can take advantage of Midwest's amazingly low prices. No middlemen's profits to pay! You save from 30% to 50% when you buy direct from the Midwest Laboratories... you get 30 days FREE trial—as little as \$5.00 down puts a Midwest radio in your home. Satisfaction guarantee or your money back. Our FREE catalog shows sensational radio values. Write for it TODAY!

MAIL COUPON TODAY! FOR AMAZING 30-DAY FREE TRIAL OFFER AND NEW 1934 CATALOG

MIDWEST RADIO CORP., Dept. 4 Cincinnati, Ohio.

Without obligation on my part send me your new FREE 1934 catalog, and complete details of your liberal 30-day FREE trial offer. This is NOT an order.

AGENTS! Make Easy Extra Money Check Here for Details

Name _____
 Address _____
 City _____ State _____

MIDWEST RADIO CORP.
 DEPT. 494 - CINCINNATI, OHIO, U. S. A.
 Established 1920 Cable Address Miraco. ABC 5th Edition

